



DTC300/DTC300M Card Printer/Encoder User Guide (Rev. 2.2)



Part Number: L000546

DTC300/DTC300M Card Printer/Encoder User Guide (Rev. 2.2), property of Fargo Electronics, Incorporated

Copyright © 2004 by Fargo Electronics, Incorporated. All rights reserved. Printed in the United States of America. Exclusive permission is granted to authorized resellers of Fargo products to reproduce and distribute this copyrighted document to authorized Fargo customers, who have signed a “no disclosure agreement” regarding the restricted, proprietary use of said document.

The revision number for this document will be updated to reflect changes, corrections, updates and enhancements to this document.

Revision Control Number	Date	Document Title
Revision 2.2	1 March 2006	DTC300/DTC300M Card Printer/Encoder User Guide
Revision 2.1	1 February 2006	Same document title
Revision 2.0	1 January 2006	Same document title
Revision 1.3	1 March 2005	Same document title
Revision 1.2	1 October 2004	Same document title
Revision 1.1	1 September 2004	Same document title
Revision 1.0	1 July 2004	Same document title

These reference documents were thoroughly reviewed to provide Fargo with professional and international standards, requirements, guidelines and models for our technical, training and user documentation. At all times, the *Copyright Protection Notice* for each document was adhered to within our Fargo documentation process. This reference to other documents does not imply that Fargo is an ISO-certified company at this time.

ANSI/ISO/ASQ Q9001-2000 American National Standard, (sub-title) Quality Management Systems - Requirements (published by the American Society of Quality, Quality Press, P.O. Box 3005, Milwaukee, Wisconsin 53201-3005)

The ASQ ISO 9000:2000 Handbook (editors, Charles A. Cianfrani, Joseph J. Tsiakals and John E. West; Second Edition; published by the American Society of Quality, Quality Press, 600 N. Plankinton Avenue, Milwaukee, Wisconsin 53203)

Juran's Quality Handbook (editors, Joseph M. Juran and A. Blanton Godfrey; Fifth Edition, McGraw-Hill)

Any questions regarding changes, corrections, updates, or enhancements to this document should be forwarded to:

Fargo Electronics, Incorporated
 Support Services
 6533 Flying Cloud Drive
 Eden Prairie, MN 55344 (USA)
 (952) 941-9470
 (800) 459-5636
 FAX: (952) 941-7836
www.fargo.com
 E-mail: sales@fargo.com

Table of Contents

Section 1: Introduction	1-1
How to use the manual	1-1
Safety Messages (review carefully)	1-2
DTC300/DTC300M Card Printer Overview	1-3
Reviewing the DTC300/DTC300M Block Diagram	1-3
Reviewing the DTC300/DTC300M Sequence of Operations	1-4
Reviewing the DTC300/DTC300M Boot up Sequence	1-6
Section 2: Specifications	2-1
Regulatory Compliances	2-1
Agency Listings	2-2
Technical Specifications	2-2
Visual Security Solutions (Specifications)	2-4
VeriMark™ Cards - 2-D holographic foil application	2-4
Custom HoloMark™ Cards	2-4
Visual Security - Card Stock Part Numbers	2-5
Visual Security - Fargo Certified Overlaminates (Special Order in 50 quantity minimum)	2-5
Visual Security Card Stock - Tolerances	2-5
VeriMark™ - Application Specifications	2-5
HoloMark™ and Custom HoloMark™ - Application Specifications	2-6
Functional Specifications	2-7
Printer Components: Front Cover to USB Port	2-8
Printer Components: Print Ribbons	2-9
Printer Components: Resin-Only Print Ribbons	2-10
Printer Components: Dye-Sublimation Print Ribbons	2-11
Printer Components: Dye-Sublimation/Resin Print Ribbons	2-12
Printer Components: Blank Cards	2-13
Printer Module: Flipper Table Module Assembly (D900200)	2-14
Section 3: Setup and Installation Procedures	3-1
Table of Contents	3-1
Printer Setup and Installation	3-3
Choosing A Good Location	3-3
About Moisture Condensation	3-3
Unpacking and Inspection	3-4
Reviewing the Printer (front view)	3-5
Reviewing the Printer (front view; Cartridge being installed)	3-5
Reviewing the LCD (top-front part of Printer)	3-6
Connecting the Printer power	3-7
Installing the Print Ribbon Cartridge	3-8
Installing Blank Cards into the Card Hopper	3-11
Lowering the Card Output Hopper	3-14
Flipper Table Module Installation	3-15
Installing the Flipper Table Module Assembly (D900200)	3-15
Printer Driver Installation	3-18
Installing the Printer Driver	3-18
Printing a Test Print Image	3-30
Printer Transport	3-32
Moving the Printer to another location	3-32
Section 4: General Troubleshooting	4-1
Table of Contents	4-1
Safety Messages (review carefully)	4-3
Communications Errors	4-4

Resolving the Communication Errors	4-4
Print Process Errors	4-6
Resolving a Card Not Fed Error (Cards will not feed off the Hopper)	4-6
Resolving a Card Not Fed Error (Two (2) or more card feed at the same time)	4-9
Resolving a Ribbon RFID Error (Ribbon RFID Antenna is Corrupted)	4-11
Resolving a Ribbon RFID Error (Ribbon RFID Sensor is Corrupted)	4-13
Resolving the Mag Verify Error	4-14
Resolving the No Mag Installed Error	4-17
Resolving a Ribbon Sensor Error (Ribbon Miscue)	4-19
Resolving a Ribbon Break Jam Error	4-21
Resolving a Ribbon Out Error	4-23
Resolving a No Ribbon Installed Error	4-24
Resolving an Invalid Ribbon Error	4-26
Resolving a Wrong Ribbon Error	4-28
Resolving a Card Jam Error	4-30
Resolving a Headlift Motor or Sensor Error	4-32
Resolving the Cover Open Error Message	4-34
Resolving the Blank Output issues	4-35
Flipper Table Module Assembly Problems	4-38
Resolving the No Flipper Table Module problem	4-38
Resolving the Flipper Jam Error	4-39
Diagnosing Image Problems	4-41
Resolving the Pixel Failure problems	4-41
Resolving the Card Surface Debris problems	4-42
Resolving the Incorrect Image Darkness problems	4-43
Resolving Ribbon Wrinkle problems	4-45
Resolving the Excessive Resin Printing problems	4-47
Resolving the Incomplete Resin Printing problems	4-49
Resolving the Image Placement problems	4-50
Resolving the Poor Image Quality problems	4-53
Running the Self Test	4-54
Running the Standard Self Test Print	4-54
Running the Magnetic Self Test (HiCo Only)	4-55
Section 5: Printer Adjustments	5-1
Table of Contents	5-1
Safety Messages (review carefully)	5-4
DTC300/DTC300M Print Driver Options	5-5
Reviewing DTC300 and DTC300M Printer Drivers	5-5
Reviewing DTC300 Printer Driver	5-5
Reviewing DTC300M Printer Drivers	5-6
Using the Card tab	5-7
Adjusting the Card Size Option	5-7
Adjusting the Orientation Option	5-8
Selecting the number of copies	5-9
Using the Diagnostics button under the Card tab	5-10
Using the Clean Printer Option	5-11
Using the Test Print button	5-13
Using the About button	5-14
Using the Device Options tab (DTC300)	5-15
Adjusting the Ribbon Type option	5-16
Selecting the Auto Ribbon Select option	5-17
Using the new Printer Driver (Rev. 2.1.5)	5-18
Changing the Color Profile Selection for the DTC300	5-18
Adjusting the Color Matching option	5-20
Adjusting for the Resin Dither	5-21

Using the Print Both Sides option	5-22
Using the Split 1 Set of Ribbon Panels option	5-23
Using the Print Back Side First option	5-24
Using the Print Back Side Only option	5-25
Using the Rotate Image 180 Degrees option	5-26
Using the Disable Printing option	5-27
Using the Device Options tab (DTC300M)	5-28
Adjusting the Ribbon Type option	5-28
Selecting the Auto Ribbon Select option	5-29
Adjusting for the Resin Dither	5-30
Using the Rotate Image 180 Degrees option	5-31
Using the Disable Printing option	5-32
Using the Resin Heat (K) option	5-33
Using the Overlay Heat (O) option	5-34
Using the Image Color tab (DTC300)	5-35
Using the Resin Heat (K) option	5-36
Using the Overlay Heat (O) option	5-37
Using the Color Matching option and Default button	5-38
Using the Calibrate tab	5-39
Using the Image Position Controls	5-40
Using the Sensors button	5-42
Using the Settings button	5-43
Using the Magnetic Encoding tab	5-44
Using the Magnetic Track Selection radio buttons	5-45
Using the Magnetic Track Options radio buttons	5-47
Using the Bit Density radio buttons	5-48
Using the Character Size radio buttons	5-49
Reviewing the Enable MLE Support checkbox	5-50
Using the ASCII Offset radio buttons	5-51
Using the LRC Generation radio buttons	5-52
Using the Character Parity radio buttons	5-52
Using the Shift Data Left checkbox	5-53
Reviewing the ISO Track Locations	5-54
Sending the Track Information	5-55
Entering the Track Information	5-55
Reviewing Tracks 1, 2 and 3 (in table format)	5-56
Reviewing the Track Data Note	5-56
Reviewing the ASCII Code and Character Table	5-57
Using the Overlay / Print Area tab	5-58
Using the Overlay / Print Area dropdown menu	5-59
Using the Overlay / Print Area	5-61
Using the Defined Area Option	5-63
Using Security Options (Visual Security Solutions)	5-68
Selecting Orientation - Landscape under Card tab	5-69
Selecting the Visual Security Solutions dropdown menu (A to D)	5-70
Selecting Orientation - Portrait under Card tab	5-71
Selecting the Visual Security Solutions dropdown menu (E to H)	5-72
Selecting the VeriMark radio button	5-73
Selecting the HoloMark radio button	5-74
Reviewing the Custom VeriMark Card (Custom Graphic in a 2D foil)	5-75
Reviewing the Custom HoloMark Card (Custom Graphic in a 2D foil)	5-76
Using the K Panel Resin tab	5-77
Selecting from the Print All Black With K Panel options	5-78
Selecting the Full Card option	5-79
Selecting the Defined Area(s) option	5-80
Selecting the Undefined Area(s) option	5-81

Selecting the Defined Area(s) function _____	5-82
Selecting the Print YMC under K and Print K Only options _____	5-89
Using the Printer Supplies tab _____	5-90
Reviewing the Ribbon Information _____	5-91
Reviewing the Ribbon Level Indicator _____	5-92
Using the Printer Calibration Utility _____	5-93
Using the Image Darkness Option _____	5-94
Using the Print Top of Form Option _____	5-95
Using the Print End of Form Option _____	5-96
Using the Print Left of Form Option _____	5-97
Using the Magnetic Encoder Voltage Offset Option _____	5-98
Using the Mag Top of Form Option _____	5-101
Using the Ribbon Tension Option _____	5-103
Using the LCD Contrast Option _____	5-103
Section 6: Cleaning _____	6-1
Safety Messages (review carefully) _____	6-1
Using the Required Supplies _____	6-2
Cleaning Procedures _____	6-3
Cleaning the Printhead _____	6-3
Cleaning the Card Feed and Cleaning Rollers _____	6-4
Cleaning the Printer's Interior _____	6-5
Section 7: Packing the Card Printer _____	7-1
Section 8: Board Level Diagnostics _____	8-1
Safety Messages (review carefully) _____	8-1
Sensor and Motor _____	8-2
Reviewing the Sensor Location and Voltages _____	8-2
Reviewing the Motor Voltages (when active) _____	8-2
Section 9: Menu Option Tree _____	9-1
Accessing the Menu Option Structure Tree _____	9-1
Selecting from the Menu Option Structure Tree (displayed, below) _____	9-1
Section 10: Firmware Upgrades _____	10-1
Introduction _____	10-1
Requirements _____	10-2
Safety Messages (review carefully) _____	10-2
Downloading Firmware _____	10-3
Placing the Printer in the Firmware Upgrade Mode _____	10-17
Sending the Firmware File _____	10-19
Section 11: Fargo Technical Support _____	11-1
Contacting Fargo Technical Support _____	11-1
Reading the Serial Numbers on a Fargo Printer _____	11-2
Finding out when a Fargo Card Printer was manufactured _____	11-2
Reviewing Example No. 1: Serial Number 80453289 _____	11-2
Reviewing Example No. 2: Serial Number A1280224 _____	11-2
Section 12: Reviewing the Spare Parts List _____	12-1
Reviewing the DTC300/DTC300M Spare Parts List _____	12-1
Section 13: Glossary of Terms _____	13-1
Section 14: Index _____	14-1



Section 1: Introduction

How to use the manual

The DTC300/DTC300M Card Printer/Encoder User Guide (Rev. 2.2) is, in fact, the troubleshooting manual for the entire card Printer. The manual is designed to provide Installers and Technicians with quick, efficient lookup of related procedures, components and terms. The manual can be used effectively either in soft or hard copy, depending on the preference of the Installer or Technician.

Manual	Description
Sequence of Operations, Glossary of Terms and Technical/Functional Specifications (hyper-linked)	You can go directly to the Sequence of Operations, Glossary of Terms, Technical Specifications and Functional Specifications to learn how to use the processes, procedures, functions and windows for the card Printer within concise, correlative tables.
Table of Contents (hyper-linked)	You can use the automated Table of Contents to quickly locate, for example, an error message, a procedure, the index, or an appendix.
Troubleshooting, Replacement, Removal, Diagnostic and Navigation Procedures (in hyper-linked Sections)	You can go directly to Specifications, General Troubleshooting, Printer Adjustments, Printer Packing, Board Level Diagnostics, LCD On-Line Menu Navigation and Firmware Updates to find troubleshooting procedures. The section titles are always labeled according to their function for consistent usage.
Cross-Referencing (hyper-linked)	You can use the cross-referencing links to quickly locate, for example, an error message or a procedure.
Comprehensive Index (hyper-linked)	You can use the COMPREHENSIVE INDEX to quickly locate information on the card Printer, relating to a specification, a procedural step, a window or screen, a component, a term, a qualifier, or a related feature to this Printer.

Safety Messages (review carefully)

Symbol	Critical Instructions for Safety purposes
<p data-bbox="289 365 407 394">Danger:</p> 	<p data-bbox="483 365 1409 428">Failure to follow these installation guidelines can result in death or serious injury.</p> <p data-bbox="483 449 1409 512">Information that raises potential safety issues is indicated by a warning symbol (as shown to the left).</p> <ul data-bbox="483 533 1409 764" style="list-style-type: none"> <li data-bbox="483 533 1409 596">• To prevent personal injury, refer to the following safety messages before performing an operation preceded by this symbol. <li data-bbox="483 617 1409 680">• To prevent personal injury, always remove the power cord prior to performing repair procedures, unless otherwise specified. <li data-bbox="483 701 1409 764">• To prevent personal injury, make sure only qualified personnel perform these procedures.
<p data-bbox="289 804 407 833">Caution:</p> 	<p data-bbox="483 804 1344 867">This device is electrostatically sensitive. It may be damaged if exposed to static electricity discharges.</p> <p data-bbox="483 888 1393 951">Information that raises potential electrostatic safety issues is indicated by a warning symbol (as shown to the left).</p> <ul data-bbox="483 972 1409 1535" style="list-style-type: none"> <li data-bbox="483 972 1409 1077">• To prevent equipment or media damage, refer to the following safety messages before performing an operation preceded by this symbol. <li data-bbox="483 1098 1409 1182">• To prevent equipment or media damage, observe all established Electrostatic Discharge (ESD) procedures while handling cables in or near the Circuit Board and Printhead Assemblies. <li data-bbox="483 1203 1409 1308">• To prevent equipment or media damage, always wear an appropriate personal grounding device (e.g., a high quality wrist strap grounded to avoid potential damage). <li data-bbox="483 1329 1409 1413">• To prevent equipment or media damage, always remove the Ribbon and Cards from the Printer before making any repairs, unless otherwise specified. <li data-bbox="483 1434 1409 1535">• To prevent equipment or media damage, take jewelry off of fingers and hands, as well as thoroughly clean hands to remove oil and debris before working on the Printer.

DTC300/DTC300M Card Printer Overview

Reviewing the DTC300/DTC300M Block Diagram

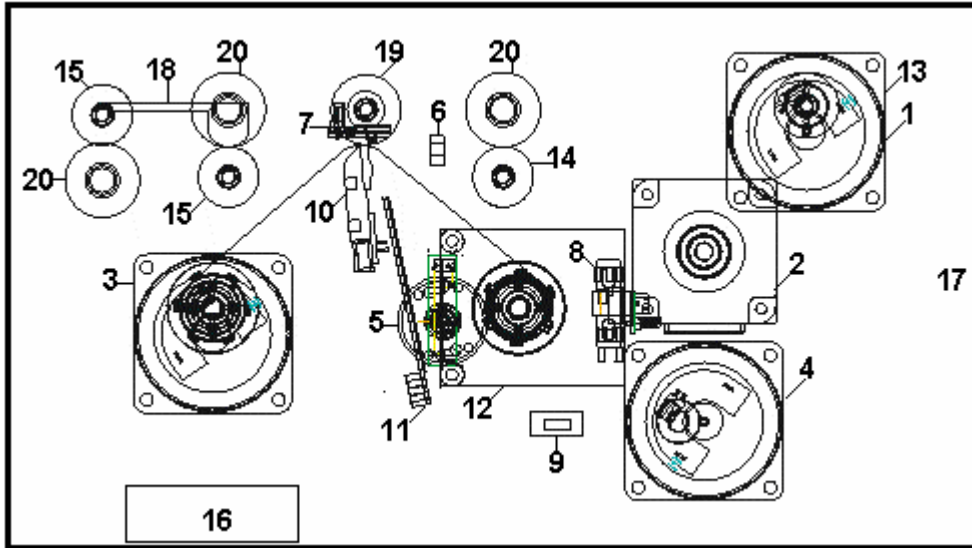

Motors	
1	Card Feed
2	Print Stepper
3	Ribbon Drive
4	Print Headlift
5	Ribbon Rewind Motor

Sensors	
6	Card Feed
7	Ribbon Sensor
8	Ribbon Encoder
9	Headlift Sensor
10	Printhead Thermistor
11	Ribbon LED SNR
12	RFID Antenna

Parts	
13	Card Input Roller
14	Cleaning Roller
15	Card Feed Roller
16	Printhead Cooling Fan
17	Card Input Hopper
18	Magnetic Encoding Head Module
19	Platen Roller
20	Pinch Roller

Reviewing the DTC300/DTC300M Sequence of Operations

The following sequence describes a full color print job with magnetic encoding.

Step	Process
1	The File information is received from the PC
2	Printer checks the installed Ribbon type stored in memory against the Ribbon type command that was sent from the Printer. a. If Ribbon type does not match, a Wrong Ribbon Error will occur.
3	The Card Input Motor and Print Stepper Motor engage.
4	The Card Feed Sensor detects leading edge of card and disengages the card input Motor.
5	The Print Ribbon Drive engages.
6	The Print Ribbon Sensor looks for the color transition from Yellow to Magenta. Print Ribbon Encoder detects number of revolutions required to use an entire color panel.
7	The Print Stepper Motor engages.
8	The Card Feed Sensor detects trailing edge of card.
9	The Print Stepper Motor queues card to the middle of the platen Roller. All Stop
10	The Print Headlift Motor engages.
11	The Print Headlift Sensor detects closed state.
12	The Print Headlift Motor disengages.
13	The Print Stepper Motor engages.
14	The Print Cover Sensor checks for a closed state.
15	The Ribbon Drive Motor engages.

Reviewing the DTC300/DTC300M Sequence of Operations

Step	Process
16	The Image data is burned by the Printhead until image data is depleted. All Stop.
17	The Thermistor engages Printhead Cooling Fan to maintain proper operating temperature.
18	The Headlift Motor engages.
19	The Print Headlift Sensor detects an open state.
20	The Print Headlift Motor disengages.
21	The Print Stepper Motor engages.
22	The Print Ribbon Drive engages.
23	The Card Feed Stepper Motor engages to queue card for magnetic encoding.
24	The Encoding data is written to the card.
25	The Card Feed Stepper will re-queue card for each verification pass required.
26	After Ribbon advances a few encoder clicks, assume Ribbon free of card. All Stop.
27	Repeat steps 9 through 23 for appropriate number of color/overlay panels.
28	The Card is ejected from the singled-sided Printer. OR The Card Feed Stepper engages to queue the card for the Flipper Table for the dual-sided Printer.
29	All Stop.

Reviewing the DTC300/DTC300M Boot up Sequence

Step	Process
1	On Power up, the Printer checks the current state of the Card Feed Sensor and the Headlift Sensor.
2	If the Headlift Sensor is found to be open, the Headlift Motor will turn until a closed state is seen.
3	If the Card Feed Sensor is found to be blocked, the Card Feed Stepper will engage to eject the card.

Section 2: Specifications

The purpose of this section is to provide the User with specific information on the Regulatory Compliances, Agency Listings, Technical Specifications and Functional Specifications for the DTC300/DTC300M Card Printer User Guide (Rev. 2.2).

Regulatory Compliances

Term	Description
CSA (cUL)	<p>The Printer manufacturer has been authorized by UL to represent the Card Printer as CSA Certified under CSA Standard C22.2 No. 60950-1-03.</p> <p>File Number: E145118</p>
FCC	<p>The Card Printer complies with the requirements in Part 15 of the FCC rules for a Class B digital device. (Note: These requirements are designed to provide reasonable protection against harmful interference in a residential installation.)</p> <p>If equipment operation in a residential area causes unacceptable interference to radio and TV reception, the operator is required to take whatever steps are necessary to correct the interference.</p>
ITS-EMC	<p>The Card Printer has been tested and complies with EN55022 Class B: 1995 and EN82082-1: 1997 standards for EMI emissions.</p> <p>(Note: Based on the above testing, the Printer manufacturer certifies that the Card Printer complies with all current EMC directives of the European Community and has placed the CE mark on the Card Printer.)</p> <p>License Number: J99032510</p>
UL	<p>The Card Printer is listed under UL IEC 60950-1 (2001) INFORMATION TECHNOLOGY EQUIPMENT.</p> <p>File Number: E145118</p>

Agency Listings

Term	Description
Emissions Standards	CE, FCC, CRC c1374, EN 55022 Class B, FCC Class B, EN 55024: 1998, EN 61000-3-2 and EN 61000-3-3.
Safety Standards	UL IEC 60950-1 (2001), CSA C22.2 No. 60950-1-03.

Technical Specifications

Type	Description
Accepted Standard Card Sizes	CR-80 (3.375"L x 2.125"W / 85.6mmL x 54mmW)
Accepted Card Thickness	20 mil and 30 mil (.030" / .76mm)
Accepted Card Types	PVC or polyester cards with polished PVC finish; monochrome resin required for straight polyester
Agency Listings	Safety: UL IEC 60950-1 (2001), CSA C22.2 No. 60950-1-03. Emissions: CE, FCC, CRC c1374, EN 55022 Class B, FCC Class B, EN 55024: 1998, EN 61000-3-2 and EN 61000-3-3.
Card Input Hopper Capacity	100 cards (30 mil)
Colors	Up to 16.7 million (monochrome)
Dimensions	Single-sided Dimensions: 6.7"H x 13.1"W x 10.5"D / 170mmH x 333mmW x 267mmD

Technical Specifications (continued)

Type	Description
Humidity	20-80% non-condensing
Interface	USB 1.1
Memory	2MB RAM
Operating Temperature	65° to 80° F / 18° to 27° C
Print Area	CR-80 edge-to-edge
Printer Drivers	Windows 98SE, Me/2000/XP
Print Method	Dye-Sublimation/Resin Thermal Transfer
Print Speed	<ul style="list-style-type: none"> • 7 seconds per card / 514 cards per hour (K)* • 12 seconds per card / 300 cards per hour (KO)* • 27 seconds per card / 133 cards per hour (YMCKO)* • 35 seconds per card / 102 cards per hour (YMCKOK)* • 35 seconds per card / 102 cards per hour (YMCFKO)* <p>* Indicates the ribbon type and the number of ribbon panels printed where Y=Yellow, M=Magenta, C=Cyan, K=Resin Black, O=Overlay, F=Flourescent</p> <p>**Print speed indicates an approximate batch print speed and is measured from the time a card feeds into the printer to the time it ejects from the printer.</p> <p>Print speeds do not include encoding time or the time needed for the PC to process the image. Process time is dependent on the size of the file, the CPU, amount of RAM and the amount of available resources at the time of the print.</p>

Technical Specifications (continued)

Type	Description
Resolution	300 dpi (11.8 dots/mm)
Supply Voltage	100-240 VAC, .6-1.3 A
Supply Frequency	50 Hz/60 Hz
System Requirements	IBM-PC or compatible; Windows 98SE, Me, 2000 and XP; Pentium™ class 233 MHz computer with 64 MB of RAM or higher, 200 MB free hard disk space or higher, USB 1.1
Weight	Single-sided Printer: 15 lbs. / 7 kg

Visual Security Solutions (Specifications)

VeriMark™ Cards - 2-D holographic foil application

VeriMark™ Cards are a low cost, customized 2-D holographic foil application, that is made in two steps.

- The first step is to emboss a base foil 1.9 cm (L) x 1.3 cm (H) onto the surface of a blank white card.
- The second step is debossing a custom-made dye into the surface of the base foil - leaving a customized image, logo or text provided by the customer.
- Two separate color foils are used to contrast the impression.

End Users will be able to choose between 8 different card placements (4 - landscape) and (4-portrait) where the VeriMark™ can be located. When its time to print through the Driver, the End User will select the location on their organizations card design around which no printing and overlay will be placed.

Custom HoloMark™ Cards

A Custom HoloMark™ Card is a three-dimensional holographic image transferred to metal foil and embossed to blank cards. The image is customer specific and the program mirrors our holographic laminates program with a couple exceptions.

Visual Security - Card Stock Part Numbers

All Visual Security Cards will be offered on the following Fargo Card Stocks only:

- P/NNo. 81754 Ultra Card
- P/NNo. 81762 Ultra Card III with hi-coercivity magnetic stripe
- P/NNo. 81763 Ultra Card III

Visual Security - Fargo Certified Overlaminates (Special Order in 50 quantity minimum)

- Part No. 82255: PolyGuard 1.0 mil for HoloMark™ and VeriMark™ Cards, Clear
- Part No. 82256: PolyGuard 1.0 mil for HoloMark™ and VeriMark™ Cards, High Resolution Globe design hologram with "Secure" micro-text

Visual Security Card Stock - Tolerances

- Tolerance of base foil placement will equal +/- .010" from the nearest edges of the card
- Tolerance of layered foil will equal +/- .010"

VeriMark™ - Application Specifications

VeriMark™ foils will cover a dimensional area of 1.9 cm length x 1.3 cm height. The exclusive areas are as follows:

- VeriMark™ Card customers will be able to choose 1 of 8 pre-defined placements (corners) via Printer Driver (4 positions) Landscape and (4 Positions) Portrait mode.
- VeriMark™ foil placement will not interfere with card punch slots .
- Foil color base is silver; debossed impression is gold foil.
- VeriMark™ foil placement will be located 0.4 cm from the edges of the card except for the top two locations on portrait orientation cards (positions E & F). The foil will be located 0.9 cm from the top of the card and 0.4 cm from the sides of the card.

HoloMark™ and Custom HoloMark™ - Application Specifications

HoloMark™ and Custom HoloMark™ foils will cover a dimensional area of 1.5 cm x 1.5 cm. The exclusive areas are as follows:

- HoloMark™ and Custom HoloMark™ card end-users will be able to choose 1 of 8 pre-defined placements (corners) via Printer Driver (4 positions) Landscape and (4 positions) Portrait mode.
- HoloMark™ foil placement will not interfere with card punch slots.
- Foil Color options will be silver or gold.
- Outside edge placement of Foil impression options on card will be 0.4 cm from edge of card.
- HoloMark™ foil placement options will be at all four corners of card located 0.4 cm from edge of card.

Functional Specifications

This Card Printer utilizes two different, yet closely related printing technologies to achieve its remarkable direct-to-card print quality for dye-sublimation and resin thermal transfer. The Card Printer will print from any IBM-PC® or compatible running Windows® 98SE, Me, Windows 2000 or Windows XP.

The following describes how each of these technologies works:

Function	Description
Dye-Sublimation	<p>Dye-Sublimation is the print method the DTC300/DTC300M uses to produce smooth, continuous-tone images that look truly photographic. (Note: This process uses a dye-based Ribbon roll that is partitioned by a number of consecutive color panels.)</p> <p>The panels are grouped in a repeating series of these three process colors along the entire length of the print Ribbon: yellow, magenta and cyan or YMC.</p> <p>The Printer always prints the yellow panel first, followed by the magenta panel and the cyan panel. (Note: As the print Ribbon passes beneath the Printhead, hundreds of thermal elements within the Printhead heat the dyes on the Ribbon. When these dyes are heated, they diffuse into the surface of the card. A separate pass is made for each of the three color panels on the Ribbon.)</p> <p>By combining the colors of each panel and by varying the heat used to transfer these colors, it is possible to print up to 16.7 million different shades of color. (Note: This blends one color smoothly into the next, producing photo-quality images with absolutely no dot pattern.)</p>
Resin Thermal Transfer	<p>Resin Thermal Transfer is the print method the Printer uses to print sharp black text and crisp bar codes, which can be read by both infrared and visible-light bar code scanners.</p> <ul style="list-style-type: none"> • Used to print ultra-fast, one-color ID cards on the DTC300/DTC300M. (Note: Like dye-sublimation, this process uses the same thermal Printhead to transfer color to a card from a resin-only print Ribbon or the resin black (K) panel of a full color print Ribbon.) • Solid dots of resin-based ink are transferred and fused to the surface of the card. (Note: This produces durable, saturated printing.)

Printer Components: Front Cover to USB Port

Components	Description
Front Cover	Opens to allow access to the Ribbon Cartridge. (Note: This cover must be closed in order for the Printer to begin printing.)
Printhead	The component of the Printer that actually does the printing. (Note: This component is fragile and must not be bumped or touched with anything other than a cleaning swab.)
Cancel button	The Cancel button  turns the Printer ON and OFF. (Note: It also serves to cancel the current print job and reset the Printer for the next print job.) If a card is left within the Printer after a print job is canceled, it will automatically be ejected when the Printer is turned back ON.
Pause button	The Pause button is used to pause the Printer during normal operation and also to resume operation after an error condition is cleared. (Note: In general, as the icon above this button indicates, errors are related to either the Ribbon or the cards. If an error occurs, the Pause LED will flash.)
Card Cleaning Roller	Automatically cleans cards for higher print quality. (Note: Clean the Card Cleaning Roller during every Ribbon change, as needed.)
Card Input Hopper	Load blank cards into this Hopper.
Flipper Cover	Opens to allow access to the Card Flipper.
E-Card Ports	Connects to the Printer's E-Card Stations.
Power Port	Connect to the included power cord.
USB Port	Connect to a Windows PC with a USB cable.

Printer Components: Print Ribbons

The Card Printer utilizes both dye-sublimation and/or resin thermal transfer methods to print images directly onto blank cards. Since the dye-sublimation and the resin thermal transfer print methods each provide their own unique benefits, print Ribbons are available in resin-only, dye-sublimation-only and combination dye-sublimation/resin versions.

To make it easier to remember which print Ribbons are which, a letter code has been developed to indicate the type of Ribbon panels found on each Ribbon. This letter code is as follows:



= Dye-Sublimation Yellow Panel



= Dye-Sublimation Magenta Panel

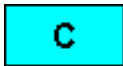

= Dye-Sublimation Cyan Panel



= Resin Black Panel

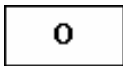



= Clear Protective Overlay Panel



= Ultra Violet Fluorescing Panel

Printer Components: Resin-Only Print Ribbons

Resin-only print Ribbons consist of a continuous roll of a single resin color. No protective overlay panel (O) is provided since resin images do not require the protection of such an overlay. The following resin-only Ribbon types are available for use with both DTC300/DTC300M:

Type	Description
Standard Resin Black (K) (provides 1,000 prints)	<p>This Ribbon provides high resin durability ideal for most general-purpose monochrome ID card applications. Resin black bar codes are readable by both infrared and visible-light bar codes scanners.</p> 
Premium Resin Black (K) (provides 1,000 prints)	<p>This Ribbon provides maximum resin durability ideal for applications such as access control where cards are repeatedly swiped through a Magnetic Stripe reader. Resin black bar codes are readable by both infrared and visible-light bar codes scanners.</p> <p>(Note: Using a Premium Resin Black Ribbon will provide better photo realistic output.)</p> 
Colored Resin (provides 1,000 prints)	<p>Several colored resin Ribbons are available in a variety of colors for customizing or color-coding resin-only ID cards.</p>
Metallic Resin (provides 1,000 prints)	<p>Metallic resin Ribbons are available for printing resin images with a unique metallic sheen.</p>

Printer Components: Dye-Sublimation Print Ribbons

The Printer requires both specialized and authorized print Ribbons in order to print and function properly.

Step	Procedure
1	<p>Do not run the cards with a contaminated, dull, or uneven surface through the Printer.</p>  <p>Caution: Printing onto such cards will ultimately lead to poor print quality and will greatly reduce the life of the Printhead.</p>
2	<p>Always store the card stock in its original packaging or in a clean, dust-free container.</p>
3	<p>Do not print onto cards that have been dropped or soiled. (Note: Printhead damage caused by contaminated or poor quality cards will automatically void the Printhead's factory warranty.)</p>
4	<p>If printing onto cards with a pre-punched slot, do not print over the area of the card with the punched slot. (Note: To avoid this area when printing, use the options in the Overlay / Print Area tab to omit printing in this area, or punch the slot after the card has printed.)</p>

Printer Components: Dye-Sublimation/Resin Print Ribbons

Type	Description
Dye-Sublimation/ resin print Ribbon	<p>The Dye-Sublimation/resin print Ribbon combines the yellow (Y), magenta (M) and cyan (C) dye-sublimation panels with a resin black (K) panel.</p> <p>By combining both types of Ribbon panels, this Ribbon can be used to print full-color, photo-quality images with the dye-sublimation panels along with sharp, black text and bar codes with the resin black panel.</p> <p>A clear overlay panel (O) is also included on most Ribbons to protect the dye-sublimation images. Dye-Sublimation images must have an overlay panel applied to them, or they will quickly begin to wear or fade.</p>
Full-Color (YMCKO) (provides 250 prints)	<p>This Ribbon is used to print full-color photo ID cards along with resin black text and bar codes. Both infrared and visible-light bar code scanners can read bar codes printed with resin black.</p> <ul style="list-style-type: none"> An overlay panel (O) is included to protect the full-color dye-sublimation printing. 
YMCKOK	<p>The designation of colored ribbon by the Panels of color in the order in which they are printed: Yellow (Y), Magenta (M), Cyan (C), Black (K), Overlay (O), Black (K) (used for backside, black only printing).</p>
YMCFKO	<p>The designation of colored ribbon by the Panels of color in the order in which they are printed: Yellow (Y), Magenta (M), Cyan (C), Black (K), Overlay (O), (used for backside, black only printing).</p>

Printer Components: Blank Cards

Type	Description
Card Size	The Card Printer accepts standard CR-80 sized (3.370"L x 2.125"W / 85.6mmL x 54mmW) with a thickness of 20 to 30 mil (.030"/.762mm).
Card Design	<p>The Printer will print onto any card with a clean, level and polished PVC surface.</p> <p>Although the Printer is equipped with card cleaning Rollers, it is very important to always print onto cards specifically designed for direct-to-card dye-sublimation printing.</p>
Card Surface	<p>Suitable cards must have a polished PVC surface free of fingerprints, dust, or any other types of embedded contaminants. In addition, cards must have a completely smooth, level surface in order for the Printer to achieve consistent color coverage.</p> <p>Certain types of Proximity cards have an uneven surface that will inhibit consistent color transfer.</p> <ul style="list-style-type: none"> • Certain types of smart card chips are raised slightly above the cards surface which also results in poor color transfer.
UltraCard Stock	<p>Due to the importance of using high-quality blank cards, a factory-approved card stock called UltraCard™ is available and recommended for best results.</p> <ul style="list-style-type: none"> • UltraCard stock has a glossy PVC laminate on top and bottom and is optically inspected to provide the cleanest, most scratch and debris-reduced cards possible. • Two types of these cards are available: UltraCard and UltraCard III. UltraCard stock has a PVC core and offers medium card durability. UltraCard III stock has a 40% polyester core and offers high durability. • Both types of UltraCards produce printed images with a glossy, photo-quality finish.

Printer Module: Flipper Table Module Assembly (D900200)

The Flipper Table Module Assembly (D900200) is an automated Flipping Module that allows the Printer to print on the frontside and backside of each card.

- See the [Installing the Flipper Table Module Assembly \(D900200\)](#) procedure.
- See the [Flipper Table Module Assembly Problems](#) procedures.
- See the **Print Both Sides** option in the [Using the Device Options tab \(DTC300/DTC300M\)](#) section.
- See the **Front** and **Back** radio buttons in the [Using the Overlay / Print Area tab \(DTC300/DTC300M\)](#) section.
- See the **Front** and **Back** radio buttons in the [Using the K Panel Resin tab \(DTC300/DTC300M\)](#) section.
- See the DTC300/DTC300M Card Printer User Guide for the replacement procedures for this Printer.

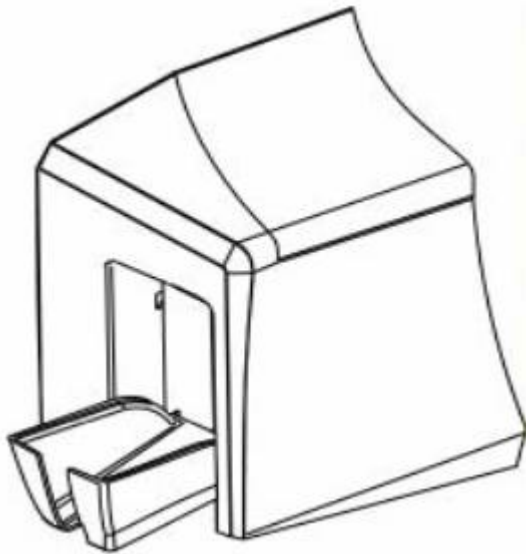

Section 3: Setup and Installation Procedures

The following guide will walk you through the installation of the DTC300/DTC300M Card Printer Driver.

- **Time Requirement (software):** This software installation process will require approximately 2 to 5 minutes (depending on the speed of your PC).
- **Time Requirement (Printer):** The time required to set up a standard DTC300/DTC300M Printer would be approximately 5 to 10 minutes.

The System Requirements are as follows:

IBM-PC or compatible, Windows® 98SE, Me/2000/XP, Pentium® class 233MHz computer with 64MB of RAM or higher, 200MB free hard disk space or higher, USB 1.1

Table of Contents

Section 3: Setup and Installation Procedures	3-1
Table of Contents	3-1
Printer Setup and Installation	3-3
Choosing A Good Location	3-3
About Moisture Condensation	3-3
Unpacking and Inspection	3-4
Reviewing the Printer (front view)	3-5
Reviewing the Printer (front view; Cartridge being installed)	3-5
Reviewing the LCD (top-front part of Printer)	3-6
Connecting the Printer power	3-7
Installing the Print Ribbon Cartridge	3-8
Installing the Print Ribbon Cartridge (continued)	3-9
Installing the Print Ribbon Cartridge (continued)	3-10
Installing Blank Cards into the Card Hopper	3-11
Installing Blank Cards into the Card Hopper (continued)	3-12
Installing Blank Cards into the Card Hopper (continued)	3-13
Lowering the Card Output Hopper	3-14
Flipper Table Module Installation	3-15
Installing the Flipper Table Module Assembly (D900200)	3-15
Installing the Flipper Table Module Assembly (D900200) (continued)	3-16
Installing the Flipper Table Module Assembly (D900200) (continued)	3-17
Printer Driver Installation	3-18
Installing the Printer Driver	3-18
Installing the Printer Driver (continued)	3-19
Installing the Printer Driver (continued)	3-20
Installing the Printer Driver (continued)	3-21
Installing the Printer Driver (continued)	3-22
Installing the Printer Driver (continued)	3-23
Installing the Printer Driver (continued)	3-24
Installing the Printer Driver (continued)	3-25
Installing the Printer Driver (continued)	3-26
Installing the Printer Driver (continued)	3-27
Installing the Printer Driver (continued)	3-28
Installing the Printer Driver (continued)	3-29
Printing a Test Print Image	3-30

Printing a Test Print Image (continued)	3-31
Printer Transport	3-32
Moving the Printer to another location	3-32

Printer Setup and Installation

Choosing A Good Location

Follow these guidelines:

- Place the unit in a location with adequate air circulation to prevent internal heat build up.
- Use the Printer's dimensions as a guideline for the minimum clearances to the unit.
(**Note:** Allow for adequate clearance in front of the unit to accommodate the unit with its Covers open.)
- Do not install unit (a) near heat sources such as radiators or air ducts, or (b) in a place subject to direct sunlight, excessive dust, mechanical vibration or shock.

About Moisture Condensation

If the unit is brought directly from a cold to a warm location, or is placed in a very damp room, moisture may condense inside the unit. Should this occur, print quality may not be optimum.

Leave the unit turned OFF in a warm, dry room for several hours before using. This will allow the moisture to evaporate.

Unpacking and Inspection

While unpacking your Printer, inspect the carton to ensure that no damage has occurred during shipping. Make sure that all supplied accessories are included with your unit.

Check that the following items are included:

- Power Supply
- US Power Cable
- Europe Power Cable
- Software Installation CD/User Guide
- User Guide
- Warranty Statement, Registration Card and Compliancy Document

Reviewing the Printer (front view)

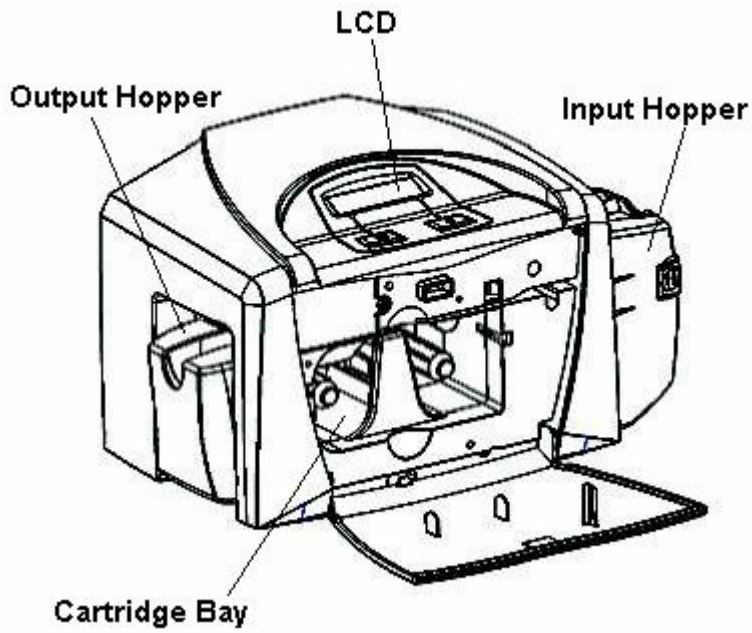

Reviewing the Printer (front view; Cartridge being installed)

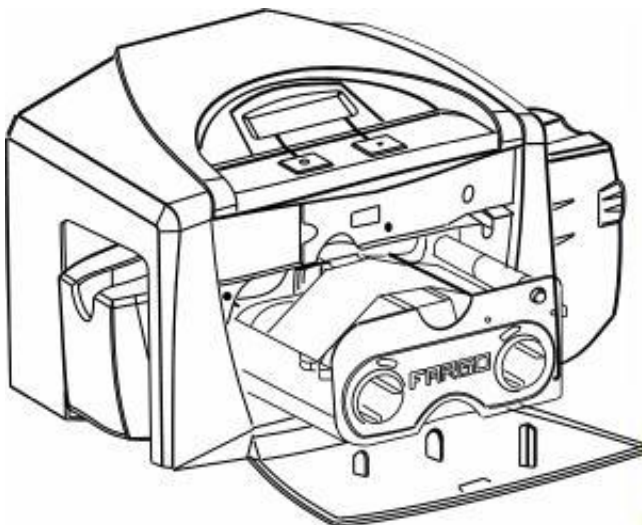

Reviewing the LCD (top-front part of Printer)

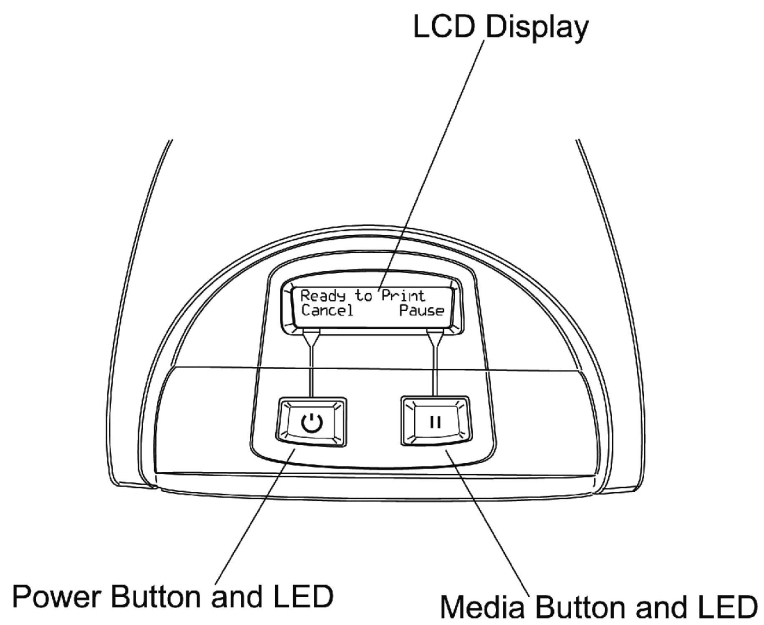

Connecting the Printer power

Follow this procedure. (**Note:** Do not connect the Printer's USB cable until prompted during the Printer Driver installation.)

Step	Procedure
1	Plug the AC adapter power cable into the back of the Printer. See Display A.
2	Plug the wall power cable into the AC power adapter.
3	Plug the wall power cable into a standard 110VAC power outlet.

Display A – Shows back of Printer with AC power cable (below).

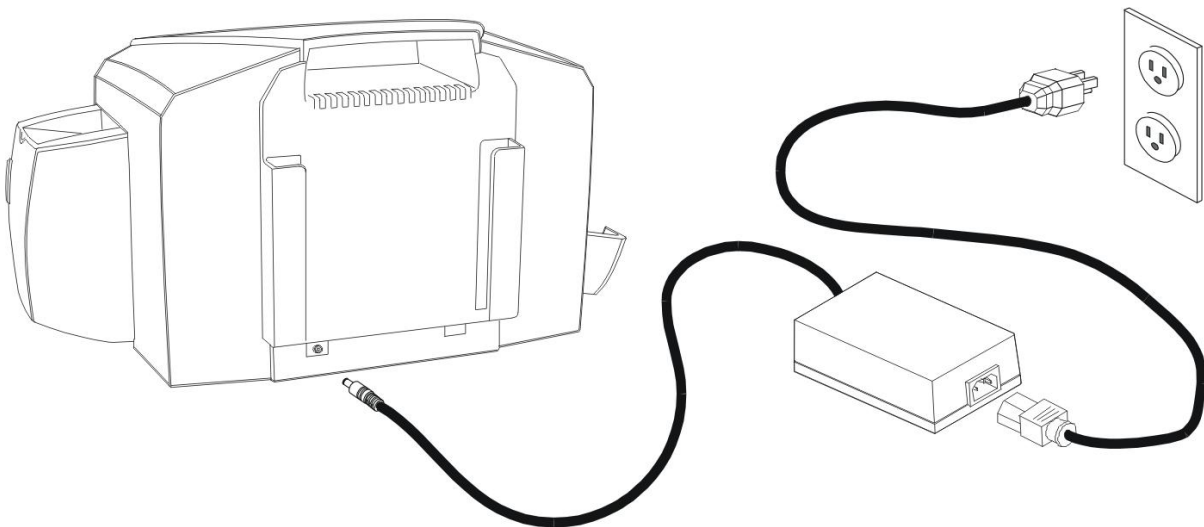

Installing the Print Ribbon Cartridge

The Fargo DTC300/DTC300M Card Printer uses a one-piece, disposable Ribbon Cartridge load system. Every full color Ribbon Cartridge contains a 250 “full color card count” Ribbon and a Card Cleaning Roller.

Step	Procedure
1	To install the Ribbon Cartridge, simply open the front Cover by pressing the black rubber pad or touch pad and lowering the Cover down, as shown below.

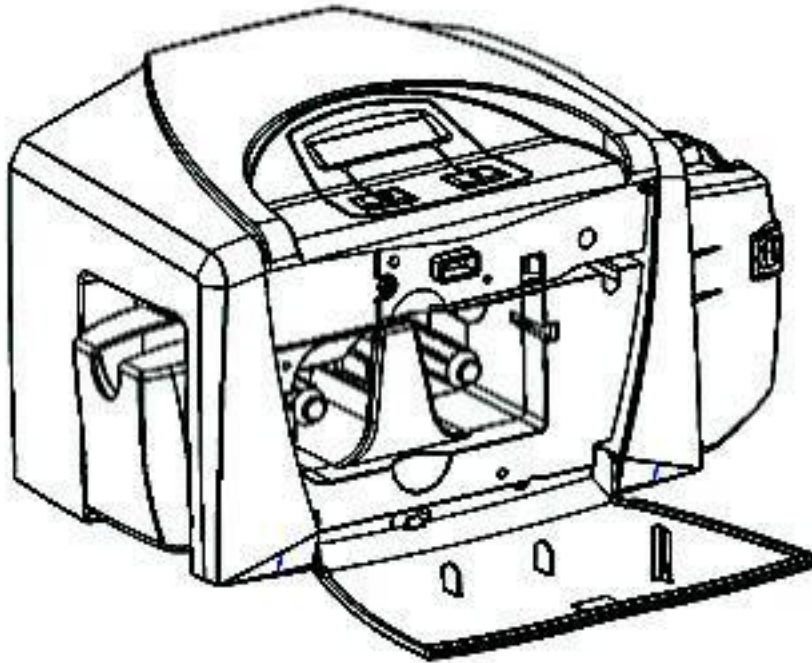

Installing the Print Ribbon Cartridge (continued)

Step	Procedure
2	a. Remove the liner on the Card Cleaning Roller before installing the Cartridge, as shown in Display A (upper right arrow of display). b. Remove the Ribbon securing tape, as shown in Display A (middle right arrow of display).
3	Slide the Ribbon Cartridge into the Printer, as shown in this section.
4	Raise the front Cover and press the front Cover's black rubber pad or touch pad to secure it.

Display A – Shows the Print Ribbon Cartridge before it is installed or inserted into the Printer. The Card Cleaning Roller (see arrow) is already inserted into the Print Ribbon Cartridge.

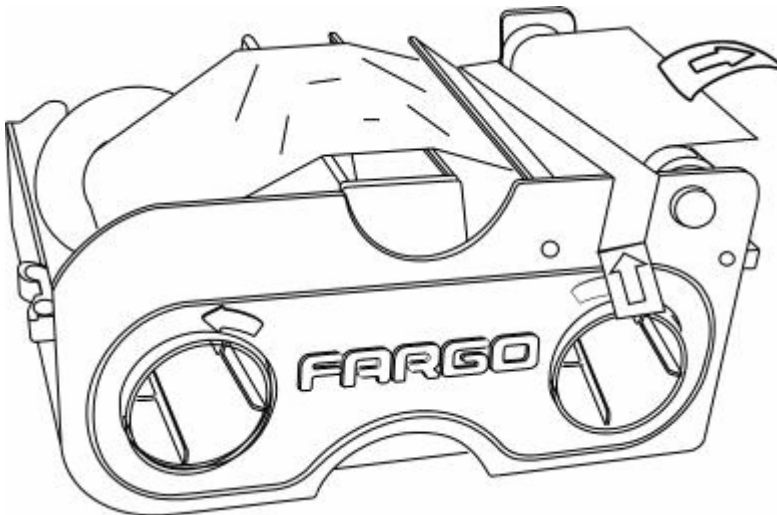

Installing the Print Ribbon Cartridge (continued)

Display B – Shows direction that Cartridge is inserted in the Printer.

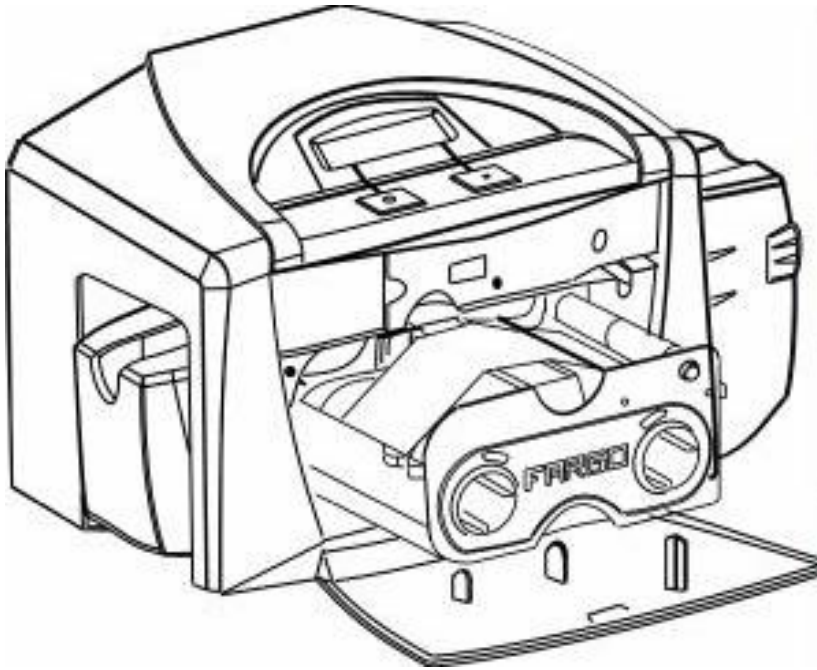

Installing Blank Cards into the Card Hopper

The Fargo DTC300/DTC300M Printer is capable of printing single load cards and multiple feed cards (batch mode).

- To print using single feed, simply remove all cards from the Card Hopper, leave the Card Hopper door closed and place a card in the single Feed Card Slot (which can be used repeatedly).
- Again, the cards should be loaded with the print side down and (if applicable) the magnetic strip up and towards the front of the Printer.

To print using Batch mode follow the instructions below.

Step	Procedure
1	Open the Card Hopper Cover.
2	Press the Card Hopper Load Lever down until the Card Tray locks into place, as shown in Display B in this section.
3	Load up to 100 cards into the Hopper with the print side down. If using cards with a magnetic strip, the magnetic strip should be loaded with the strip up and to the front of the Printer, as shown in Display C in this section.
4	Close the Card Hopper Cover to release the Card Tray.

Continued on the next page

Display A – This is a graphics showing how to insert the cards.

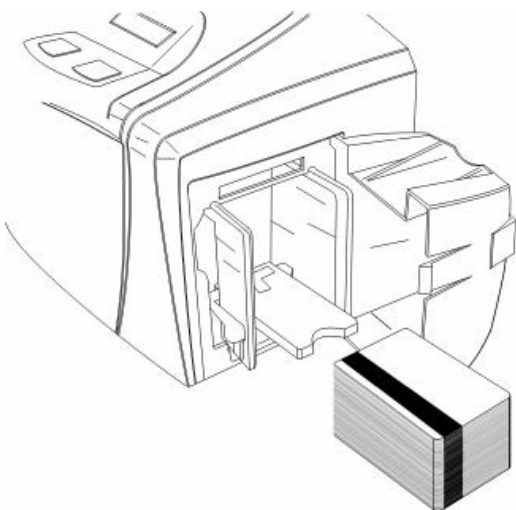

Installing Blank Cards into the Card Hopper (continued)

Display B - Press the Card Hopper Load Lever down. Insert the cards.

Here the Lever is still up.

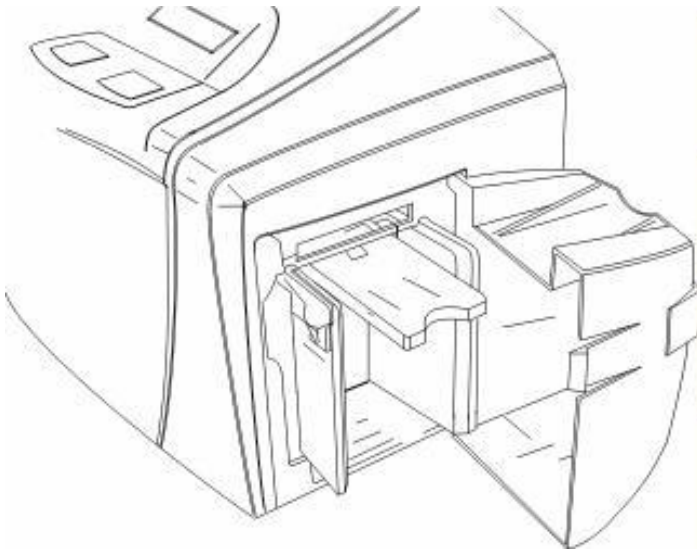

Here the Lever is pressed down.

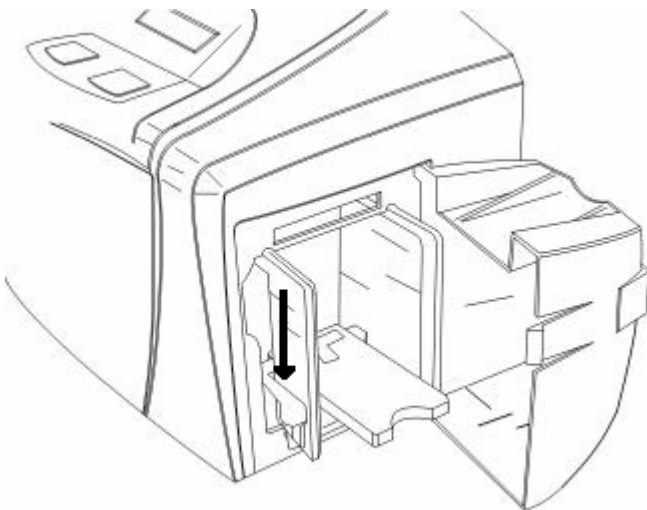

Continued on the next page

Installing Blank Cards into the Card Hopper (continued)

Here are the cards ready to insert.

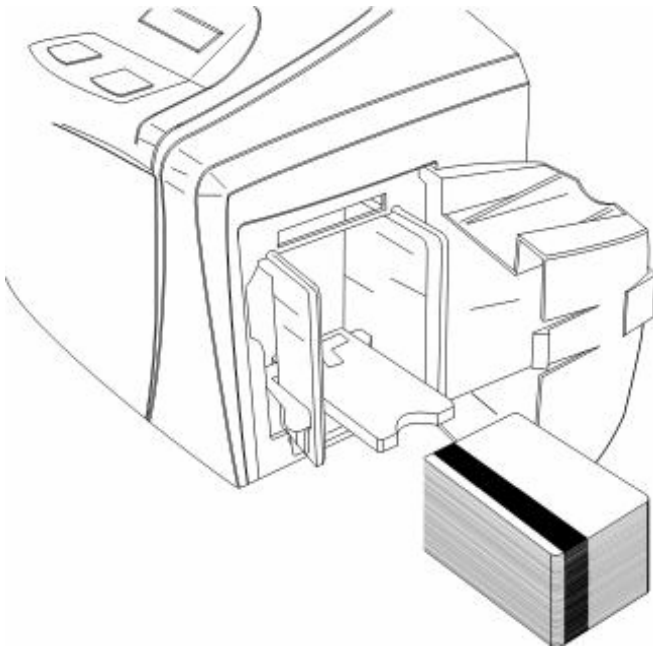

Here the Input Hopper Door is closed.

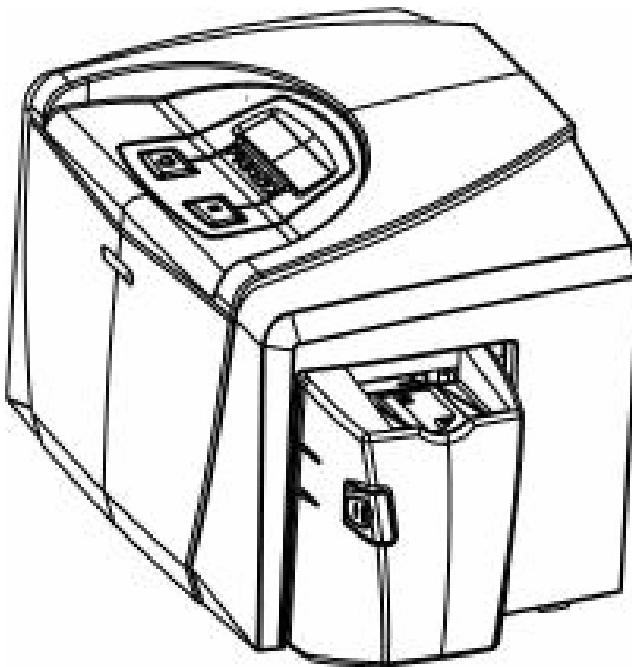

Continued on the next page

Lowering the Card Output Hopper

Step	Procedure
1	The Fargo DTC300/DTC300M comes with a Card Output Hopper (to hold cards after they have been printed). Pull on the Output Hopper and lower its Cover down until it snaps into place.



Flipper Table Module Installation

Additional, related links are provided below:

Installing the Flipper Table Module Assembly (D900200)

Step	Description
1	 Caution: Turn off the Printer and unplug the power cord from the Printer.
2	Remove the Rear Cover (D90066) to the Printer.

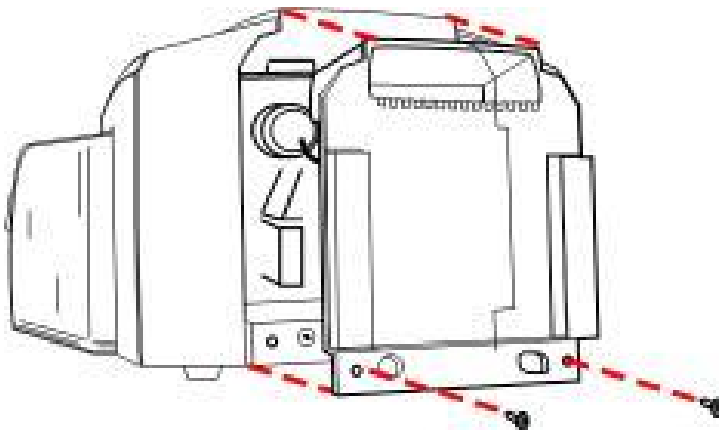

Installing the Flipper Table Module Assembly (D900200) (continued)

Step	Description
3	Remove the Card Output or Exit Door (D900092) and Left End Cap (D900064) to the Printer, as shown below.

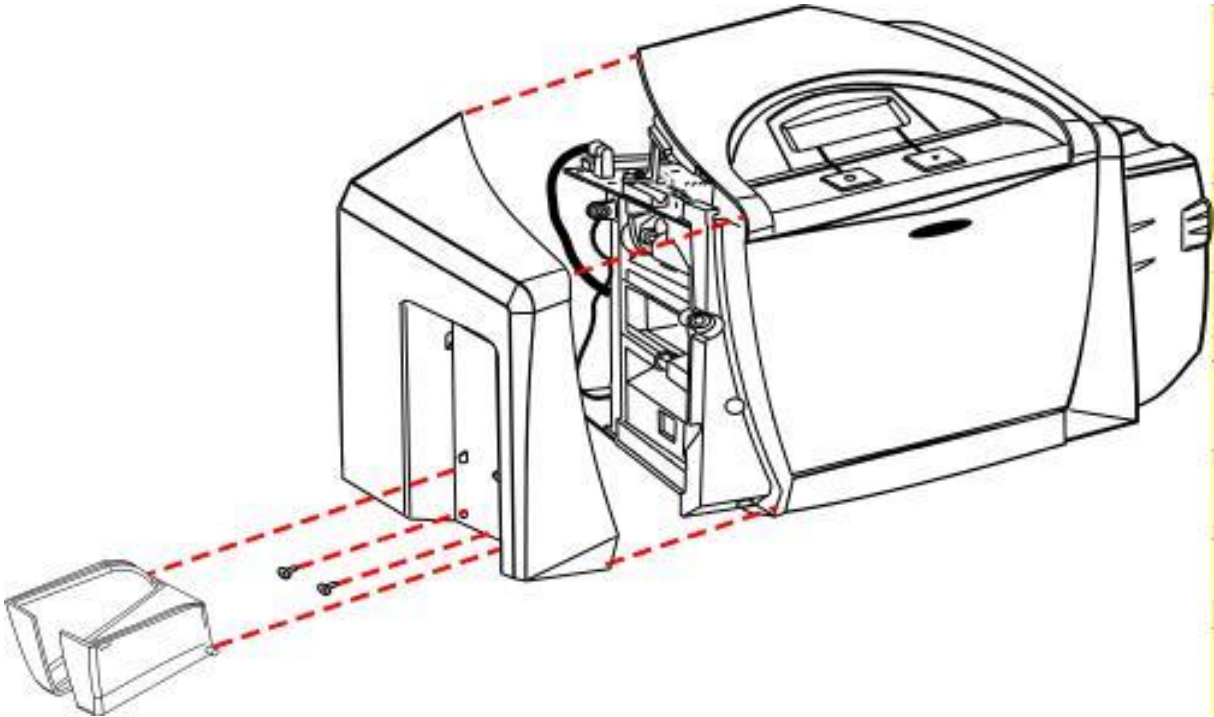

Installing the Flipper Table Module Assembly (D900200) (continued)

Step	Description
4	a. Remove the Cover from the Flipper Table Module Assembly (D900200), as shown below. b. Place the Flipper Table next to Printer, as shown below.
5	Connect the Flipper Table Module cable, as shown below.
6	Slide in the Flipper Table Module pins, as shown below.
7	Attach the Flipper Table Module pin screw, as shown below.
8	Use the Torx T-10 screwdriver to attach the one (1) front Baseplate mount screws (F000170), as shown below.
9	Attach the Flipper Table Module Cover, as shown below.
10	Connect the USB and Power cables, as shown below.

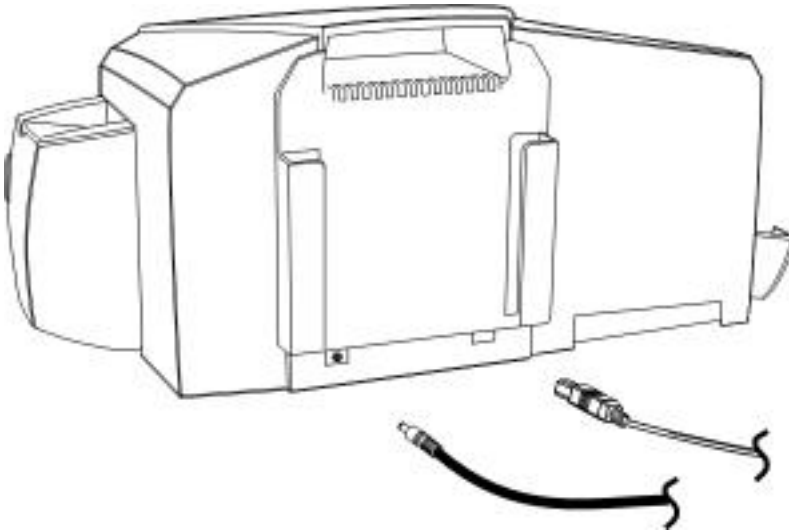

Printer Driver Installation

Installing the Printer Driver

Step	Procedure
1	<p>Close all programs and insert the Software Installation CD into your computer's CD drive. After a few seconds, the CD's installer program will automatically open. Follow the CD's on-screen Procedures to complete installation.</p> <p>(Note: If the CD does not automatically open, use "My Computer" or "Windows Explorer" to view the contents of the CD. Then, double-click on the Setup.exe file listed on the CD.)</p>
2	<p>Click on the following buttons to install the appropriate Printer Driver and Online User's Guide, as shown below:</p> <ul style="list-style-type: none"> • DTC300 Card Printer/Encoder button • DTC300M Card Printer/Encoder button

Continued on the next page



Installing the Printer Driver (continued)

Step	Procedure
3	Wait during the installation.

Continued on the next page



Installing the Printer Driver (continued)

Step	Procedure
4	Click on the Next button to continue with the Setup program.

Continued on the next page

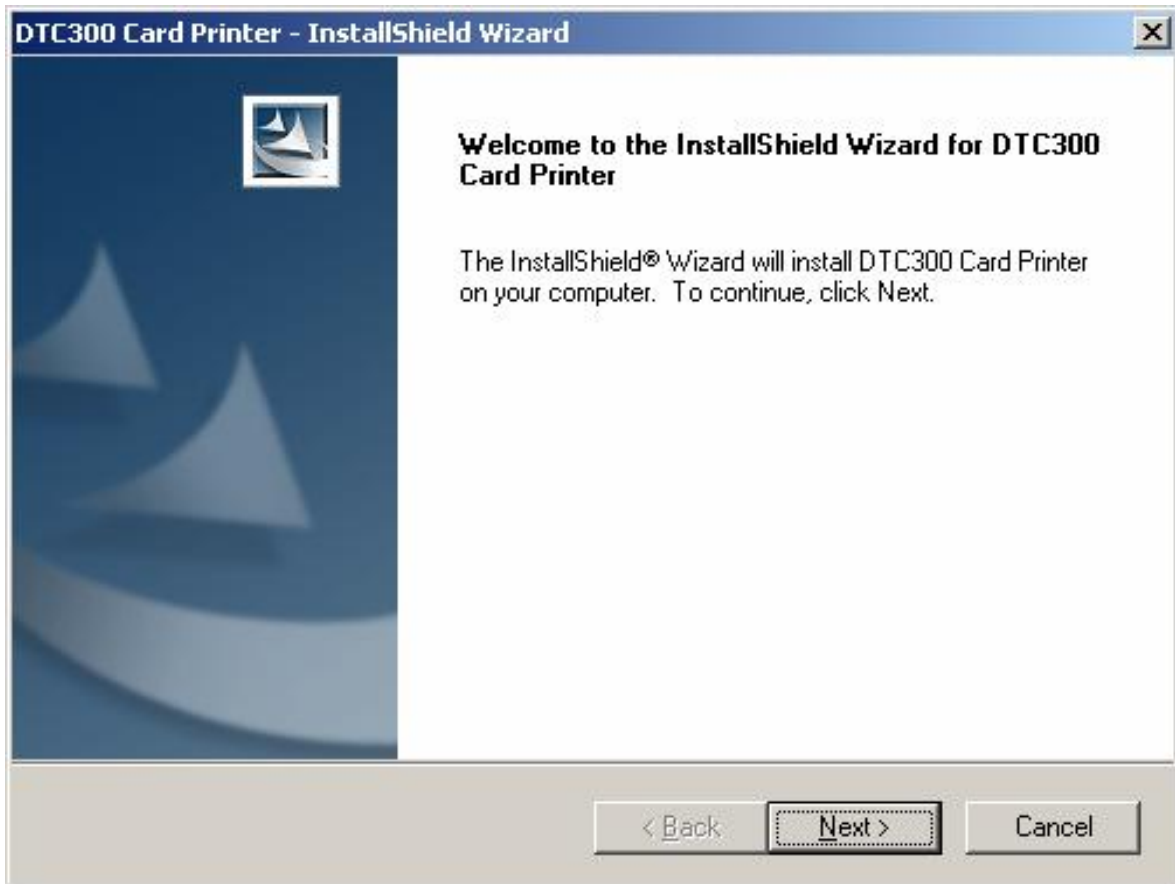

Installing the Printer Driver (continued)

Step	Procedure
5	Read the License Agreement. Select the I accept the terms of the license agreement option and click Next to continue.

Continued on the next page

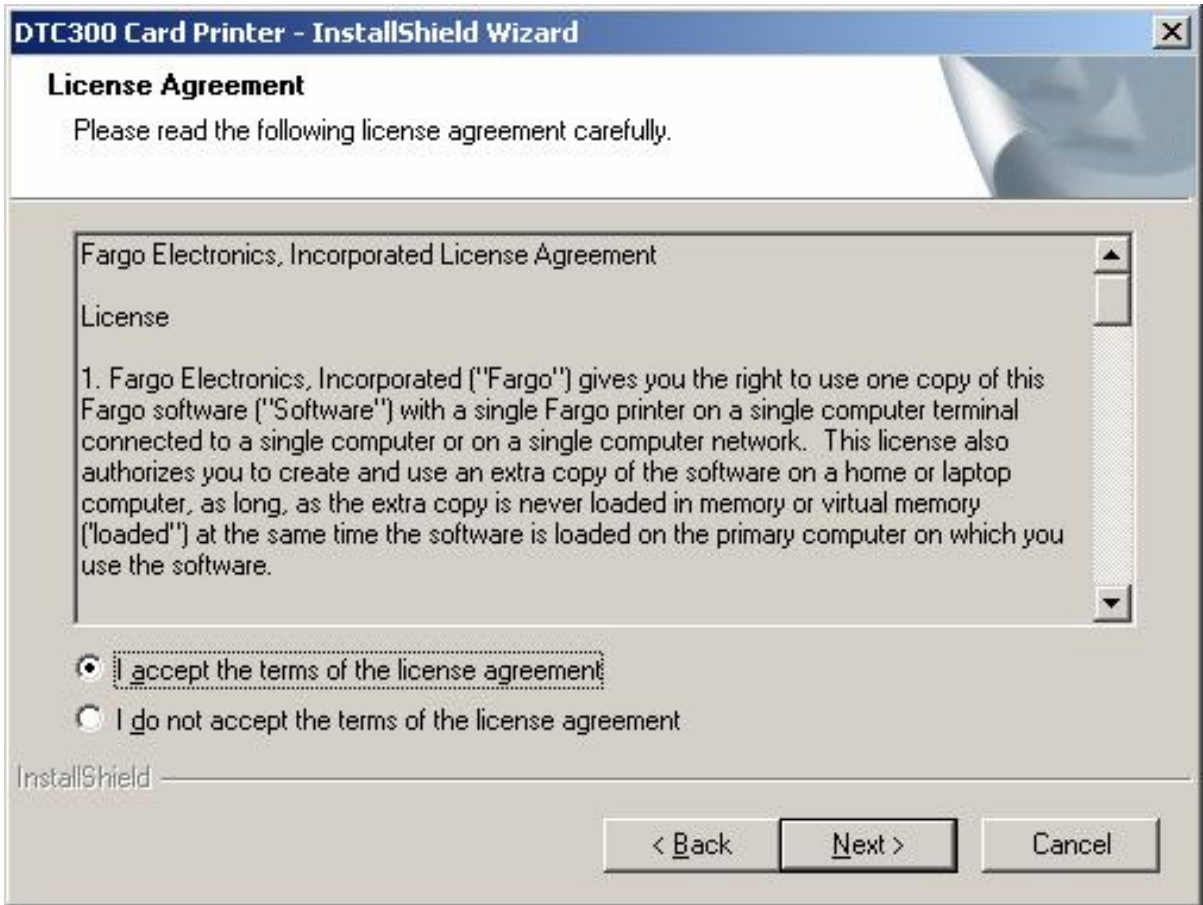

Installing the Printer Driver (continued)

Step	Procedure
6	<p>a. Select the Complete option to install the following components:</p> <ul style="list-style-type: none"> • Printer Driver Software • Printer Driver User's Guide • Fargo Diagnostics Utility <p>(Note: Selecting Custom will provide the option to select which components to install.)</p> <p>b. Click Next to continue.</p>

Continued on the next page

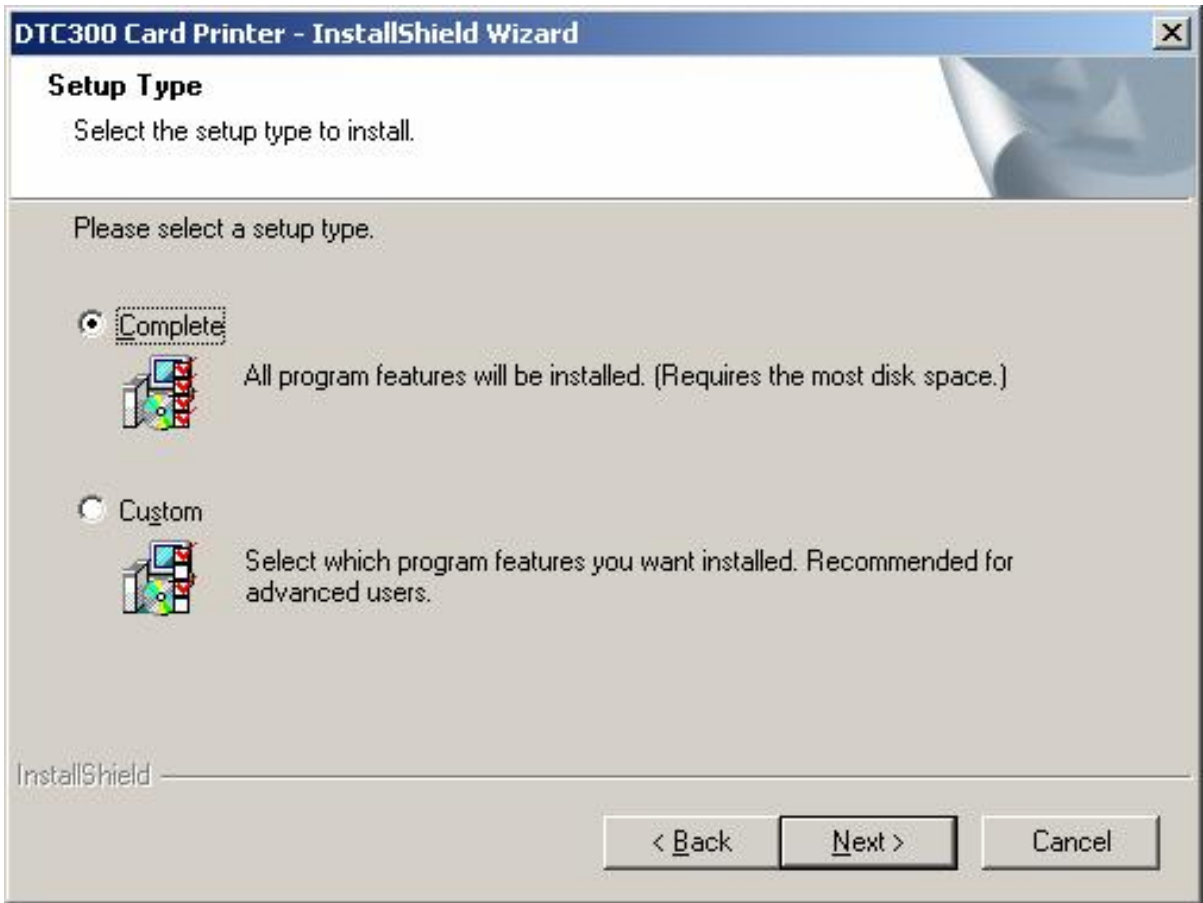

Installing the Printer Driver (continued)

Step	Procedure
7	Click Install to begin the installation.

Continued on the next page

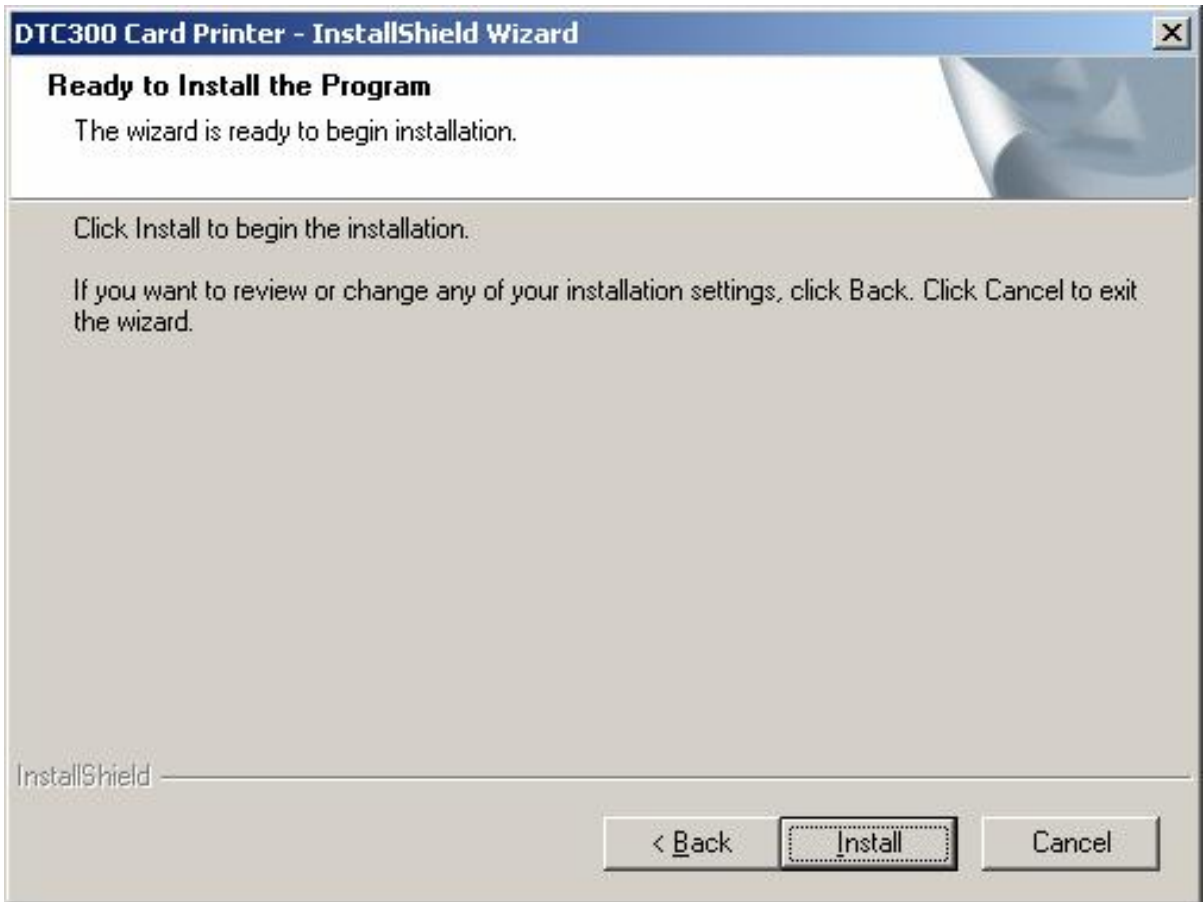

Installing the Printer Driver (continued)

Step	Procedure
8	Select the port that your Printer is connected to at this time. Click on the OK button and continue with the installation.

Continued on the next page

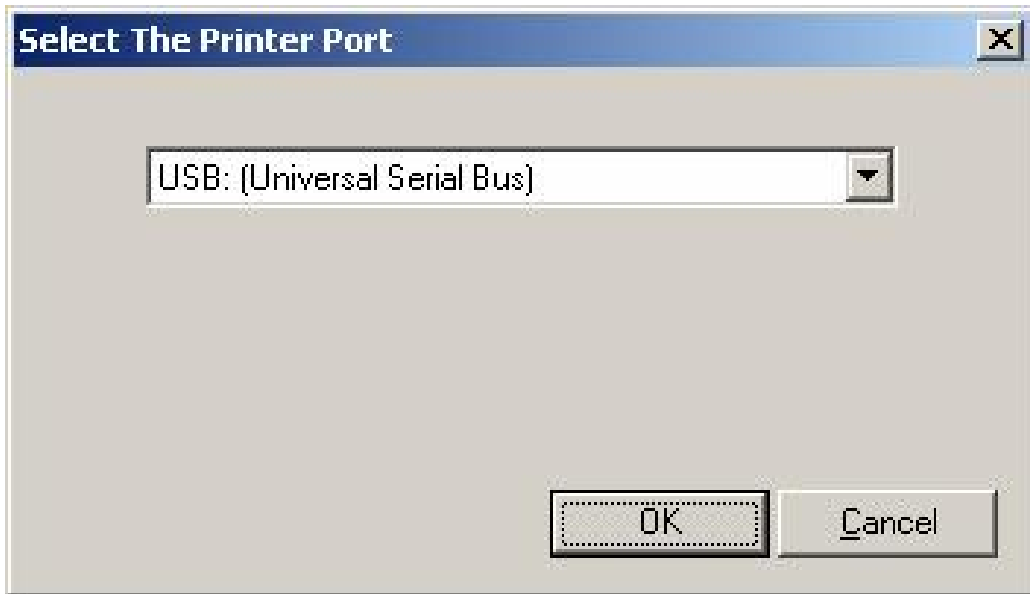

Installing the Printer Driver (continued)

Step	Procedure
9	a. Connect the USB cable to the Printer. b. Turn ON the Printer at this time if it is not already ON.

Continued on the next page



Installing the Printer Driver (continued)

Step	Procedure
10	Wait while the Driver components are being copied to your PC.

Continued on the next page

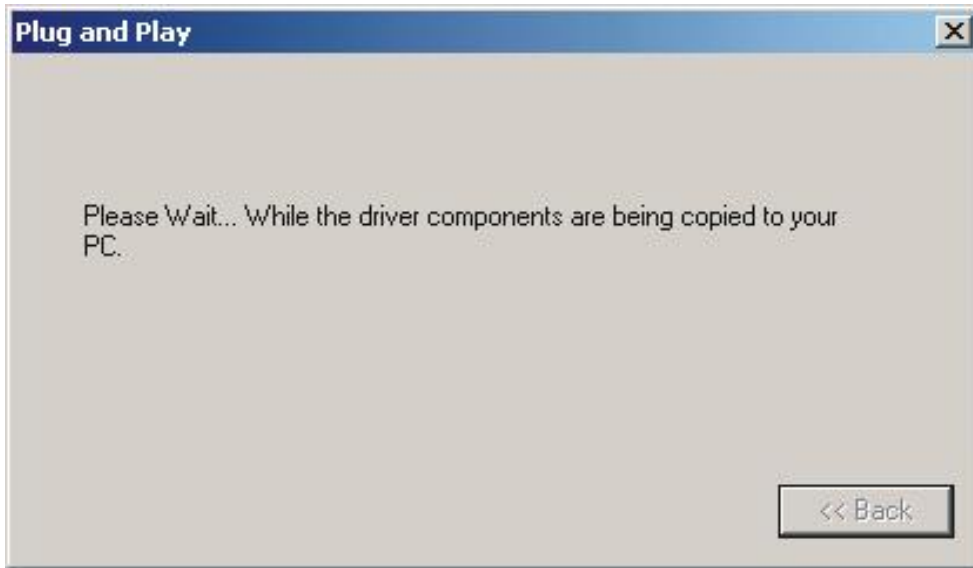

Installing the Printer Driver (continued)

Step	Procedure
11	Click on the Finish button to complete the Setup, as shown below.

Continued on the next page

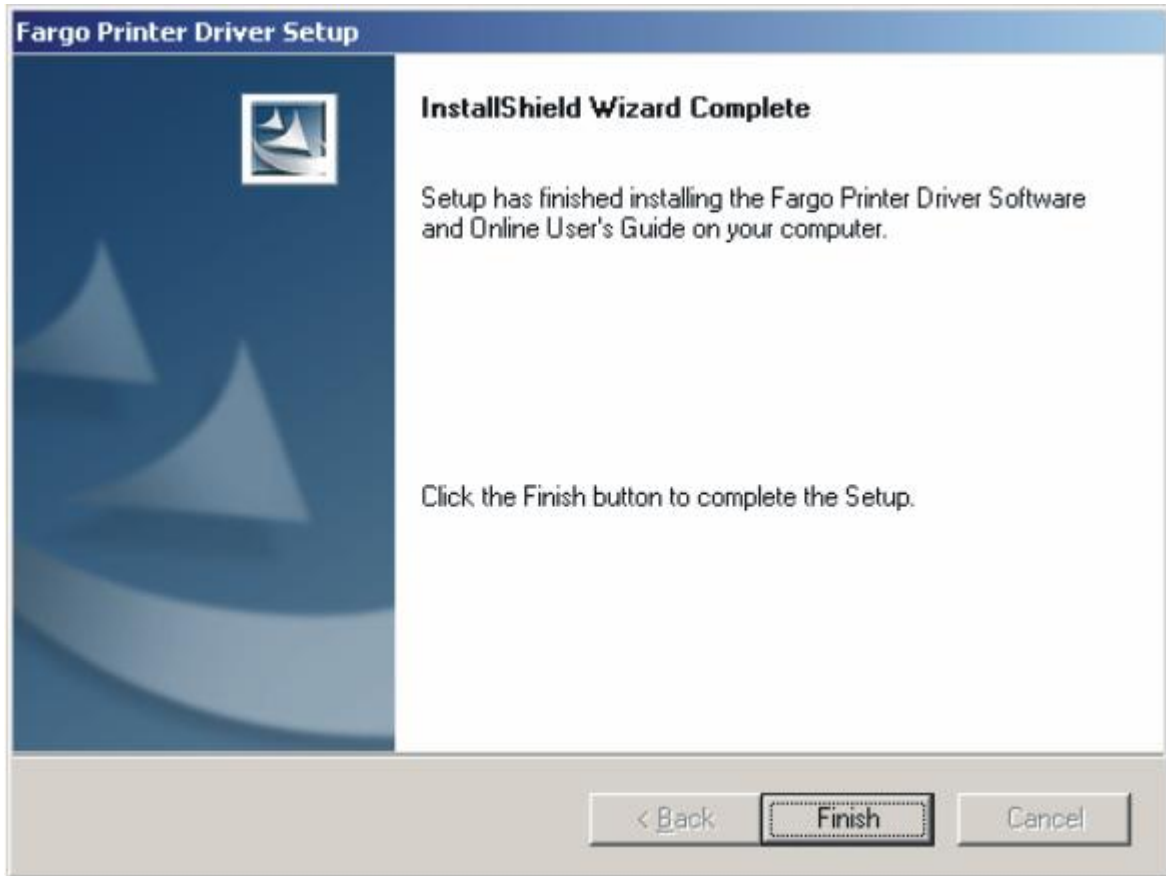

Installing the Printer Driver (continued)

Step	Procedure
12	a. Click on the Yes button to exit the installer, as shown below. b. Click on the No button to return to the installer's main menu to install additional software components.

Continued on the next page



Installing the Printer Driver (continued)

Step	Procedure
13	You have completed the installation.



Printing a Test Print Image

Step	Procedure
1	<ol style="list-style-type: none"> From your computer's startup menu, select Settings > Printers and Faxes (Windows XP) or > Printers (Windows 98SE, Me and 2000). Double click on the DTC300/DTC300M Card Printer under the Printers window. Select Printing Preferences under the Printer drop-down menu. This will bring up the DTC300/DTC300M Printing Preferences window.
2	<ol style="list-style-type: none"> Select the Card tab, and then click on the Test Print button, as shown in Display A in this section. (Note: Ensure that a full color YMCKO Ribbon is installed before proceeding.) When the Test Print button is selected, an image is copied to the Printer.

Display A - DTC300/DTC300M Printer Driver Card Tab:

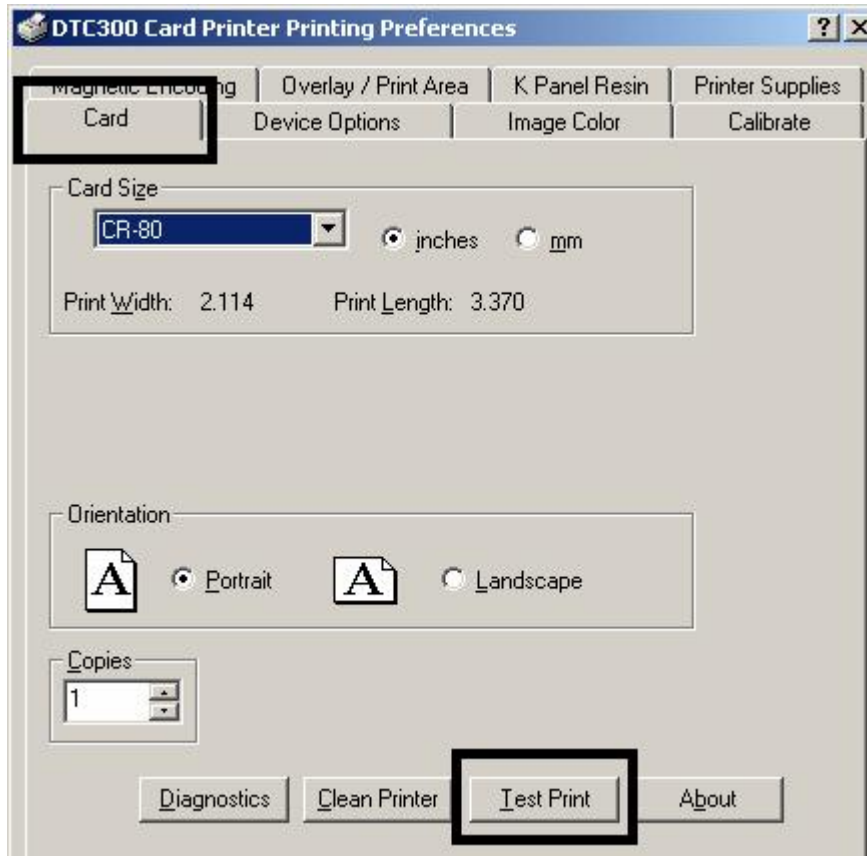

Continued on the next page

Printing a Test Print Image (continued)

Step	Procedure
3	This completes the DTC300/DTC300M Card Printer/Encoder Installation Guide. For additional help regarding the Test Print and other related items please see the DTC300/DTC300M Card Printer User Guide located under Start > Programs > Fargo.

Printer Transport

Moving the Printer to another location

Step	Procedure
1	The Printer can be transported by gripping it under the back lid, as shown in the photo below.
2	You have completed the setup and installation procedures in this section.

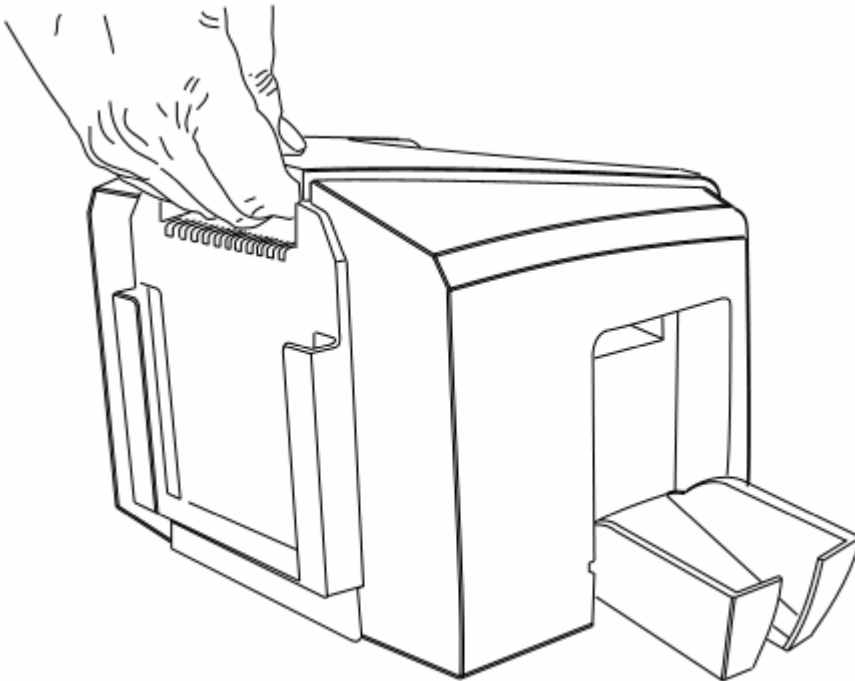

Section 4: General Troubleshooting



This section provides Troubleshooting procedures for this Printer for Communication Errors, Card Feed Errors, Print Process Errors, Card Jam Errors, Encoding Errors and Diagnosing Image Problems.

Table of Contents

Section 4: General Troubleshooting	4-1
Table of Contents	4-1
Safety Messages (review carefully)	4-3
Communications Errors	4-4
Resolving the Communication Errors	4-4
Resolving the Communication Errors (continued)	4-5
Print Process Errors	4-6
Resolving a Card Not Fed Error (Cards will not feed off the Hopper)	4-6
Resolving a Card Not Fed Error (Cards will not feed off the Hopper) (cont.)	4-7
Resolving a Card Not Fed Error (Cards will not feed off the Hopper)	4-8
Resolving a Card Not Fed Error (Two (2) or more card feed at the same time)	4-9
Resolving a Card Not Fed Error (Two (2) or more card feed at the same time) (cont.)	4-10
Resolving a Ribbon RFID Error (Ribbon RFID Antenna is Corrupted)	4-11
Resolving a Ribbon RFID Error (Ribbon RFID Antenna is Corrupted) (cont.)	4-12
Resolving a Ribbon RFID Error (Ribbon RFID Antenna is Corrupted) (cont.)	4-12
Resolving a Ribbon RFID Error (Ribbon RFID Sensor is Corrupted)	4-13
Resolving the Mag Verify Error	4-14
Resolving the Mag Verify Error (continued)	4-15
Resolving the Mag Verify Error (continued)	4-16
Resolving the No Mag Installed Error	4-17
Resolving the No Mag Installed Error (continued)	4-18
Resolving a Ribbon Sensor Error (Ribbon Miscue)	4-19
Resolving a Ribbon Sensor Error (Ribbon Miscue) (continued)	4-20
Resolving a Ribbon Break Jam Error	4-21
Resolving a Ribbon Break Jam Error (continued)	4-22
Resolving a Ribbon Out Error	4-23
Resolving a No Ribbon Installed Error	4-24
Resolving a No Ribbon Installed Error (continued)	4-25
Resolving a Invalid Ribbon Error	4-26
Resolving a No Ribbon Installed Error (continued)	4-27
Resolving a Wrong Ribbon Error	4-28
Resolving a Wrong Ribbon Error (continued)	4-29
Resolving a Card Jam Error	4-30
Resolving a Wrong Ribbon Error (continued)	4-31
Resolving a Headlift Motor or Sensor Error	4-32
Resolving a Headlift Motor or Sensor Error (continued)	4-33
Resolving the Cover Open Error Message	4-34
Resolving the Blank Output issues	4-35
Resolving the Blank Output issues (continued)	4-36
Resolving the Blank Output issues (continued)	4-37
Flipper Table Module Assembly Problems	4-38
Resolving the No Flipper Table Module problem	4-38
Resolving the Flipper Jam Error	4-39
Resolving the Flipper Jam Error (continued)	4-40
Diagnosing Image Problems	4-41
Resolving the Pixel Failure problems	4-41

Resolving the Card Surface Debris problems _____	4-42
Resolving the Incorrect Image Darkness problems _____	4-43
Resolving the Incorrect Image Darkness problems (continued) _____	4-44
Resolving Ribbon Wrinkle problems _____	4-45
Resolving Ribbon Wrinkle problems (continued) _____	4-46
Resolving the Excessive Resin Printing problems _____	4-47
Resolving the Excessive Resin Printing problems (continued) _____	4-48
Resolving the Incomplete Resin Printing problems _____	4-49
Resolving the Image Placement problems _____	4-50
Resolving the Image Placement problems (continued) _____	4-51
Resolving the Image Placement problems (continued) _____	4-52
Resolving the Poor Image Quality problems _____	4-53
Running the Self Test _____	4-54
Running the Standard Self Test Print _____	4-54
Running the Magnetic Self Test (HiCo Only) _____	4-55

Safety Messages (review carefully)

Symbol	Critical Instructions for Safety purposes
<p>Danger:</p> 	<p>Failure to follow these installation guidelines can result in death or serious injury.</p> <p>Information that raises potential safety issues is indicated by a warning symbol (as shown to the left).</p> <ul style="list-style-type: none"> • To prevent personal injury, refer to the following safety messages before performing an operation preceded by this symbol. • To prevent personal injury, always remove the power cord prior to performing repair procedures, unless otherwise specified. • To prevent personal injury, make sure only qualified personnel perform these procedures.
<p>Caution:</p> 	<p>This device is electrostatically sensitive. It may be damaged if exposed to static electricity discharges.</p> <p>Information that raises potential electrostatic safety issues is indicated by a warning symbol (as shown to the left).</p> <ul style="list-style-type: none"> • To prevent equipment or media damage, refer to the following safety messages before performing an operation preceded by this symbol. • To prevent equipment or media damage, observe all established Electrostatic Discharge (ESD) procedures while handling cables in or near the Circuit Board and Printhead Assemblies. • To prevent equipment or media damage, always wear an appropriate personal grounding device (e.g., a high quality wrist strap grounded to avoid potential damage). • To prevent equipment or media damage, always remove the Ribbon and Cards from the Printer before making any repairs, unless otherwise specified. • To prevent equipment or media damage, take jewelry off of fingers and hands, as well as thoroughly clean hands to remove oil and debris before working on the Printer.

Communications Errors

Resolving the Communication Errors

Symptom(s): Incorrect output, communications error on PC or Printer, stalling, no response from Printer, no job printed, “paper out” error.

Step	Procedure
1	Confirm that the system meets the minimum requirements, as shown here: <ul style="list-style-type: none"> • IBM-PC or compatible. • Windows 98SE, Me/2000/XP Pentium™ class 233 MHz computer with 64 MB of RAM or higher • 200 MB free hard disk space or higher • USB Port
2	Confirm the correct installation of the Printer Driver. <ol style="list-style-type: none"> a. Close the software program and check the Printer Driver. b. Reboot the computer. c. Ensure the Printer Driver is installed correctly. (Note: Especially if an obsolete Driver was recently removed.) d. Ensure the correct setup options within the Printer Driver are selected. e. Confirm that the Driver is current by checking at: www.fargo.com
3	Confirm the correct installation of the Flipper Table Module Assembly. <ol style="list-style-type: none"> a. Reboot the computer. b. Ensure that the Print Both Sides option in the Printer Driver is set correctly. c. Verify the Flipper Table Module Assembly is functioning properly by printing out cards in a test run. d. If you are experiencing problems, see Resolving the No Flipper Table Module problem.

Resolving the Communication Errors (continued)

Step	Procedure
4	<p>Determine the problem with printing from the application.</p> <ol style="list-style-type: none"> a. Print a self-test from the Printer by holding down the Pause button on power up to ensure that the Printer (itself) is functioning properly. b. Print the Windows test page that is located in the General tab of the Driver. c. Use WordPad (a Windows 98SE, Me/2000/XP word processing program in the Accessories Program Group). <ol style="list-style-type: none"> 1) Go to the File menu and select Page Setup. 2) Click on the Printer button and select the DTC300/DTC300M Card Printer. 3) Click OK and reset all four margins to zero. (Note: The WordPad will automatically replace the values with its minimum margins.) 4) Open the program and type: "This is a Test." then, go to File on the menu bar and select Print.
5	<p>Determine whether there is adequate hard Drive space.</p> <p>(Note: A large volume of temporary files on the computer can cause communications errors.)</p> <ol style="list-style-type: none"> a. Access the temporary files by following this process: <ul style="list-style-type: none"> • Search for all folders called TEMP. Once found, clear out the contents of the folders. • If using Windows 98SE, Me/2000/XP, run the System Utility - Disk Defragmenter found in the Accessories folder of the Start Menu. • Use a disk cleanup utility (such as Disk Cleanup found in the System Tools folder of the Start menu) or use a third party application.

Print Process Errors

All Troubleshooting procedures assume that only factory-authorized supplies are in use in the Printer.

Resolving a Card Not Fed Error (Cards will not feed off the Hopper)

Step	Procedure
1	<p>Review the following information.</p> <ul style="list-style-type: none"> • Symptom: Cards will not feed at all. • Printer Error State: Card is not being detected by the Card TOF Sensor 11 seconds after the initiation of a print job causing the Printer to produce an error • LCD Error Display: Card Not Fed • Driver Monitor Error Display: Unable to Feed Card



Resolving a Card Not Fed Error (Cards will not feed off the Hopper) (cont.)

Step	Procedure
2	<p>Check the card quality / loading.</p> <ol style="list-style-type: none"> Remove cards from the Card Hopper. Ensure that the cards are not sticking together by fanning them out and then lining them back together in straight deck. Press the Card Hopper Load Lever down until the Card Tray locks into place. Load up to 100 cards into the Hopper with the print side down. Close the Card Hopper Cover to release the Card Tray. Press on the Resume button. If the cards do not feed, continue to Step 3.
3	Press the Cancel Print button on the Driver Monitor Error Display Message.
4	Reboot the Printer by cycling the power.
5	<p>Check the Card Feed Motor.</p> <ol style="list-style-type: none"> Remove all cards from the Hopper. Press the Card Hopper Load Lever down until the Card Tray locks into place. Using the Fargo Diagnostic utility send a test print to the Printer. See the Using the Diagnostic Utility tabs. Gently touch the Card Hopper Feed Roller to verify that it is turning If Roller is NOT turning, continue to Step 7. If Roller is turning, continue to Step 6.
6	<p>Check Hopper Tray Spring Tension.</p> <ol style="list-style-type: none"> Open Card Hopper Cover. Using the Fargo Diagnostic utility, send a test print to the Printer. See the Using the Diagnostic Utility tabs. When the Card Hopper Feed Roller engages, push up on the Card Hopper Tray. If the cards feed, replace the Card Hopper Lift Spring. If the cards do not feed, replace the Card Hopper Feed Roller.

Resolving a Card Not Fed Error (Cards will not feed off the Hopper)

Step	Procedure
7	<p>Card Hopper Feed Roller is not turning during a print job.</p> <ol style="list-style-type: none">a. Remove the Printer rear cover.b. Ensure that the Card Hopper Feed Motor power cable is securely connected to J-20 on the Printers Main Board.c. Ensure that the Card Hopper Feed Motor power cable is securely connected to the Card Hopper Feed Motor.d. Use the Fargo Diagnostic utility to send a test print to the Printer. See the Using the Diagnostic Utility tabs.e. If the Card Hopper Feed Motor is not moving, continue to Step 8.
8	<p>Replace Card Hopper Feed Motor.</p> <ol style="list-style-type: none">a. Replace the Card Hopper Feed Motor.b. Use the Fargo Diagnostic utility to send a test print to the Printer. See the Using the Diagnostic Utility tabs.c. If the Card Hopper Feed Motor does not turn, replace the Main Board.

Resolving a Card Not Fed Error (Two (2) or more card feed at the same time)

All Troubleshooting procedures assume that only factory-authorized supplies are in use in the Printer.

Step	Procedure
1	<p>Review the following information.</p> <ul style="list-style-type: none"> • Symptoms: Two or more cards feed at the same time causing the cards to jam at the Card Hopper Roller. Printer is out of cards. • Printer Error State: Card is not being detected by card TOF Sensor 11 sec after the initiation of a print job causing the Printer to produce an error • LCD Error Display: Card Not Fed • Driver Monitor Error Display: Unable to Feed Card



Resolving a Card Not Fed Error (Two (2) or more card feed at the same time) (cont.)

Step	Procedure
2	Check card quality / loading. <ol style="list-style-type: none"> a. Remove cards from the Card Hopper. b. Ensure that the cards are not sticking together by fanning them out and then lining them back together in straight deck. c. Press the Card Hopper Load Lever down until the Card Tray locks into place. d. Load up to 100 cards into the Hopper with the print side down. e. Close the Card Hopper Cover to release the Card Tray. f. Press on the Resume button. g. If the cards do not feed, continue to Step 3.
3	Press the Cancel Print button on the Driver Monitor Error Display Message.
4	Reboot the Printer by cycling the power.
5	Check Card Feed TOF Sensor. <ol style="list-style-type: none"> a. Remove the Printers rear cover. b. Use a digital volt meter to place the Positive lead to pin 9 of the J-4 Main Board connection and the negative lead to pin 12 of the J-4 Main Board connection. <ul style="list-style-type: none"> • The blocked Sensor should read +4.99 vdc. • The open Sensor should read +1.5 vdc. c. If the Card Feed TOF Sensor does not read properly, replace the Sensor.
6	Clean the Card Feed Roller.

Resolving a Ribbon RFID Error (Ribbon RFID Antenna is Corrupted)

All Troubleshooting procedures assume that only factory-authorized supplies are in use in the Printer.

Step	Procedure
1	<p>Review the following information.</p> <ul style="list-style-type: none">• Symptom: Printer RFID Sensor does not detect a recognizable signal from the Ribbon.• Printer Error State: The Ribbon tag information is corrupted or incorrect.• LCD Error Display: Ribbon RFID Error• Driver Monitor Error Display: Ribbon RFID Error

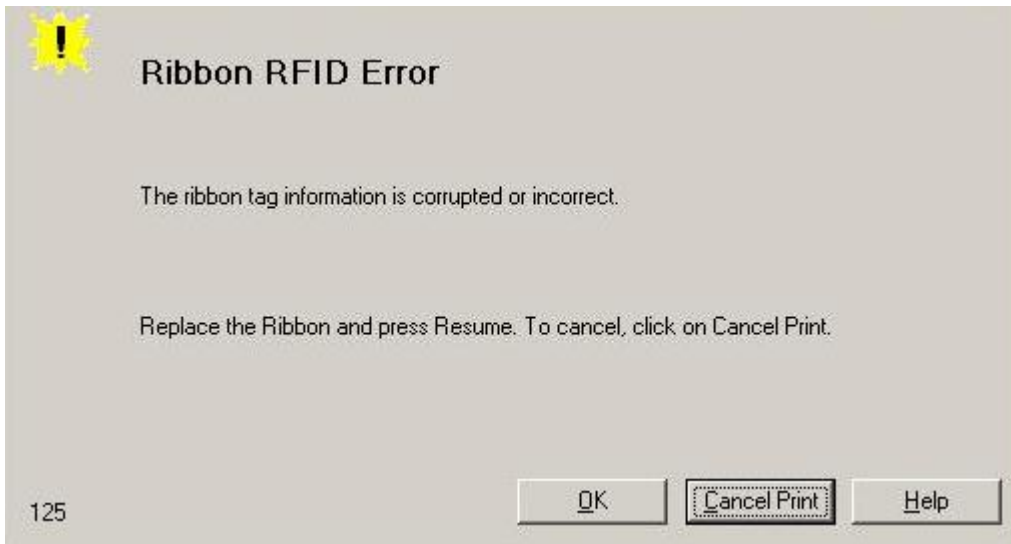

Resolving a Ribbon RFID Error (Ribbon RFID Antenna is Corrupted) (cont.)

Step	Procedure
2	Replace the Print Ribbon <ol style="list-style-type: none"><li data-bbox="358 401 870 432">a. Replace the Print Ribbon Cartridge.<li data-bbox="358 447 792 478">b. Press on the Resume button.<li data-bbox="358 493 1365 562">c. If the error continues, see Resolving the Ribbon RFID Error (Ribbon RFID Sensor is Corrupted) in this section.

Resolving a Ribbon RFID Error (Ribbon RFID Sensor is Corrupted)

All Troubleshooting procedures assume that only factory-authorized supplies are in use in the Printer.

Step	Procedure
1	<p>Review the following information.</p> <ul style="list-style-type: none"> • Symptom: Printer RFID Sensor does not detect a recognizable signal from the Ribbon. • Printer Error State: The Ribbon tag information is corrupted or incorrect. • LCD Error Display: Ribbon RFID Error • Driver Monitor Error Display: Ribbon RFID Error
2	<p>Replace the Print Ribbon RFID Sensor.</p> <ol style="list-style-type: none"> a. Replace the Print Ribbon RFID Sensor. b. Press on the Resume button. c. If the error continues, replace the Printer Main Board.

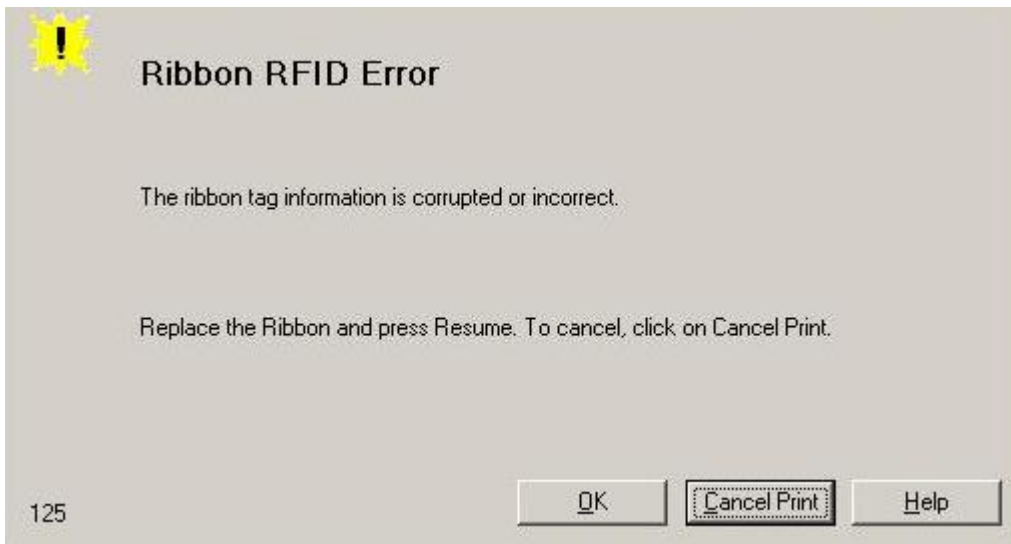

Resolving the Mag Verify Error

All Troubleshooting procedures assume that only factory-authorized supplies are in use in the Printer.

Step	Procedure
1	<p>Review the following information.</p> <ul style="list-style-type: none">• Symptom: The Printer is unable to verify encoded data.• Printer Error State: The Printer is unable to verify encoded data.• LCD Error Display: Mag Verify• Driver Monitor Error Display: Mag Verify

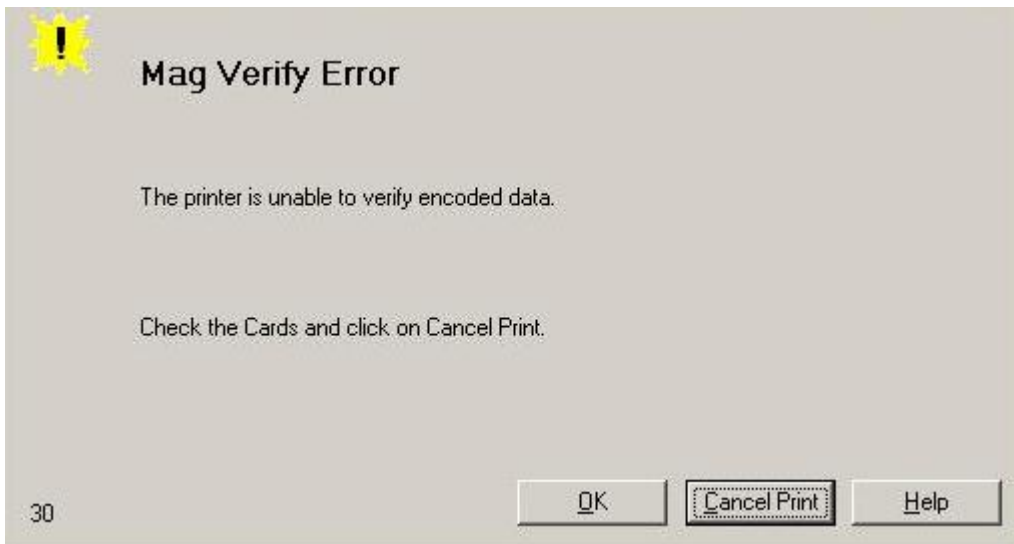

Resolving the Mag Verify Error (continued)

Step	Procedure
2	Check to ensure that the cards are loaded with the Magnetic Stripe facing Up and towards the front of the Printer.
3	a. Press on the Resume button. b. If the error continues continue to step 4
4	Verify the Driver settings if cards are loaded properly. See the Using the Magnetic Encoding tab (DTC300/DTC300M) procedure.
5	Verify that data is being encoded to the Magnetic Stripe. <ol style="list-style-type: none"> a. Clear any Error Messages from the LCD by unplugging the Printer and reapplying power. b. Remove the failed card. c. Use a Magnetic Stripe reader or magnetic developer spray to determine if data is being written to the Magnetic Stripe. d. If data is not being written to the Magnetic Stripe, <ul style="list-style-type: none"> • Open the front cover. • Remove the Magnetic Module cover screw. • Remove the Magnetic Module cover. • Verify that the Magnetic Module is seated securely into the Magnetic Module docking station. e. If the Magnetic Module is properly seated, replace the magnetic head (as needed). (Note: See the current DTC300/DTC300M User Guide for related instructions in the Parts Replacement Section.) f. If data is being written to the Magnetic Stripe, the Magnetic Offset may need to be adjusted. See the Using the Mag Top of Form Option procedure.

Resolving the Mag Verify Error (continued)

Step	Procedure
6	Verify that the coercivity of the cards matches the Driver Settings.

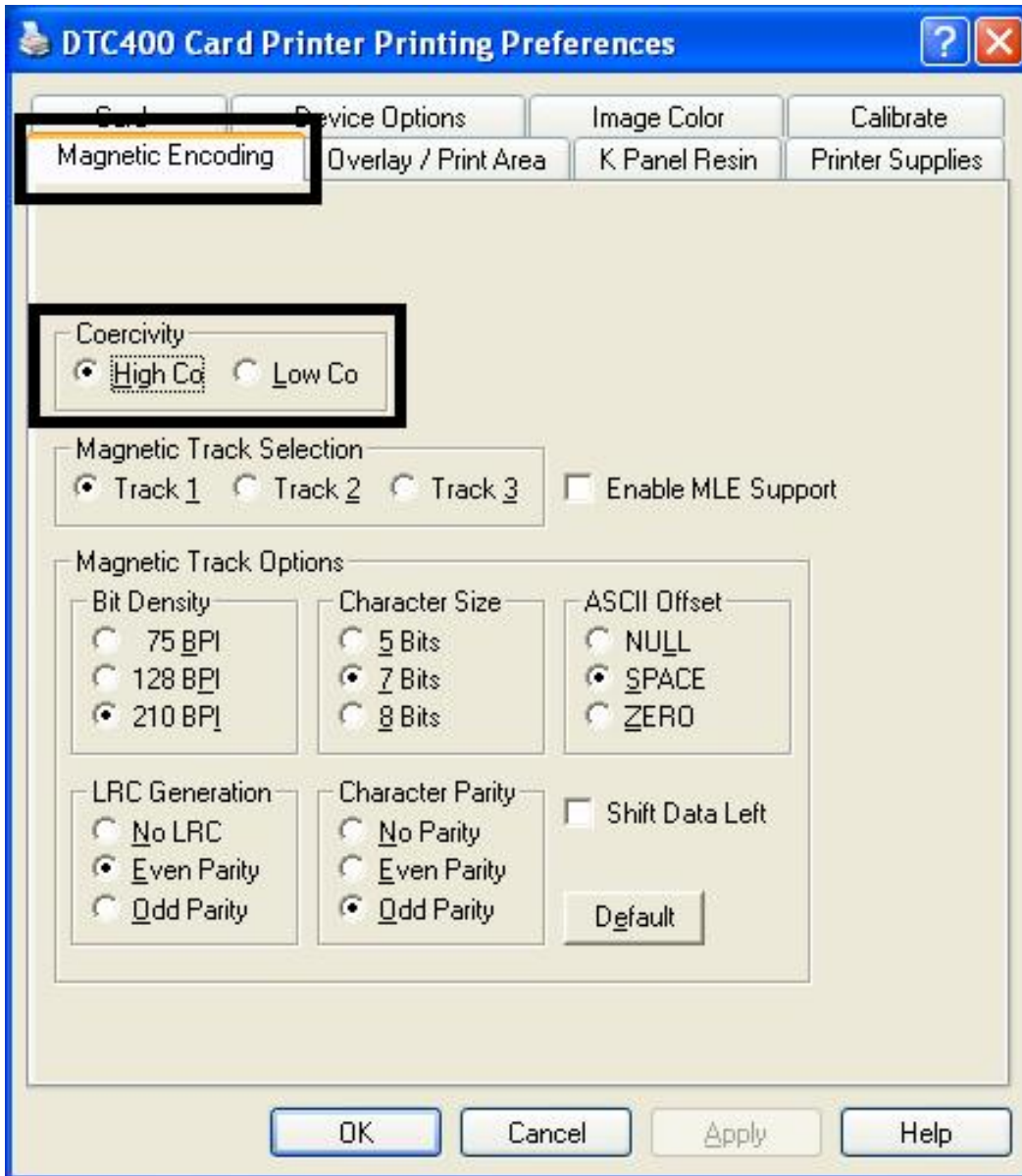

Resolving the No Mag Installed Error

All Troubleshooting procedures assume that only factory-authorized supplies are in use in the Printer.

Step	Procedure
1	<p>Review the following information.</p> <ul style="list-style-type: none"> • Symptom: There is not Magnetic Encoder installed. • Printer Error State: A print job with Magnetic encoding was sent with no Magnetic encoder installed in the Printer. • LCD Error Display: No Mag Installed • Driver Monitor Error Display: No Mag Installed

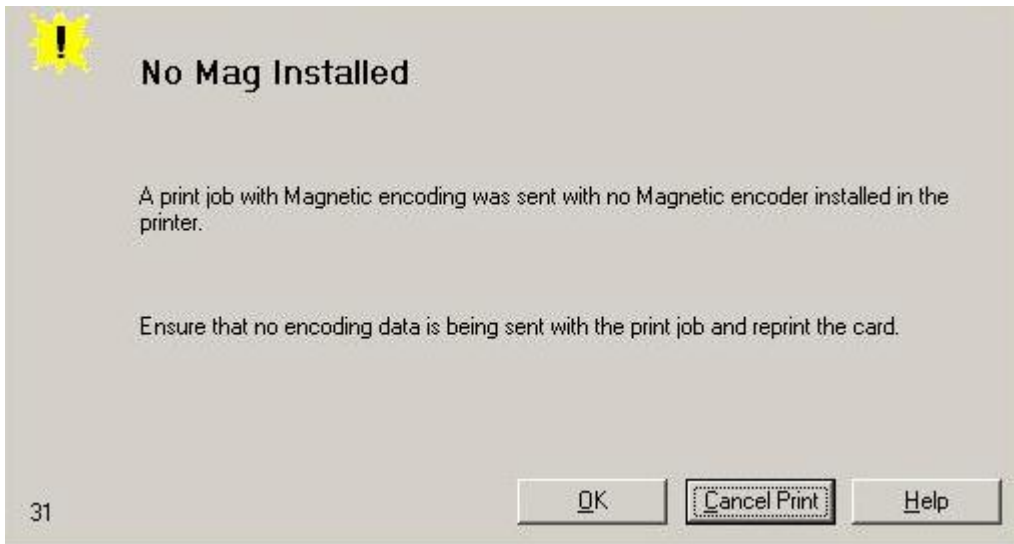

Resolving the No Mag Installed Error (continued)

Step	Procedure
2	Press the Cancel Print button on the Driver Monitor Error Display Message.
3	Reboot the Printer by cycling the power.
4	<p>Verify that the Printer has a Magnetic Encoder installed.</p> <ol style="list-style-type: none"> a. Open the front cover. b. Remove the Magnetic Module cover screw. c. Remove the Magnetic Module cover. d. Verify that the Printer has a Magnetic Module installed. (Note: If the Printer is equipped with a Magnetic Encoder Module, ensure that it is seated securely into the Magnetic Module docking station. If the issue persists, replace the Magnetic Module. See the DTC300/DTC300M service manual for replacement procedures.)
5	If the Printer has no Magnetic Encoder Module, verify that the encoding data was sent in error, check the appropriate software user's manual for encoding instructions.

Resolving a Ribbon Sensor Error (Ribbon Miscue)

All Troubleshooting procedures assume that only factory-authorized supplies are in use in the Printer.

Step	Procedure
1	<p>Review the following information.</p> <ul style="list-style-type: none">• Symptom: The Printer rolls through Ribbon and errors out• Printer Error State: The Printer cannot find the next panel on the Ribbon.• LCD Error Display: Ribbon Miscue• Driver Monitor Error Display: Ribbon Sensor

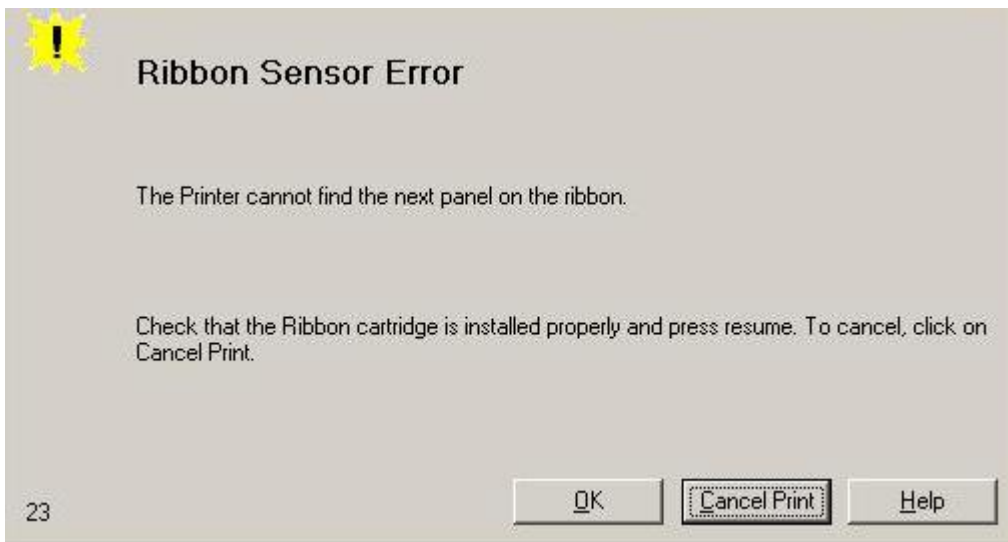

Resolving a Ribbon Sensor Error (Ribbon Miscue) (continued)

Step	Procedure
2	Open the front cover and remove the Ribbon Cartridge. a. Check that the Ribbon is in good condition and not wrinkled or broken. b. If Ribbon is broke or wrinkled, repair the Ribbon and wind up the take-up roll 4-color panels past the damaged area.
3	Press on the Resume button. If the issue persists, continue to Step 4.
4	Replace the Ribbon Cartridge. a. Press on the Resume button. b. If the issue persists, continue to Step 5.
5	Press the Cancel Print button on the Driver Monitor Error Display Message.
6	Reboot the Printer by cycling the power.
7	Using the driver calibration tab calibrate the Ribbon Sensor. If the issue persists, continue to Step 8.
8	Replace the Ribbon Sensor.

Resolving a Ribbon Break Jam Error

All Troubleshooting procedures assume that only factory-authorized supplies are in use in the Printer.

Step	Procedure
1	<p>Review the following information.</p> <ul style="list-style-type: none"> • Symptom: The Print Ribbon has become jammed or has broken in the Printer • Printer Error State: The Ribbon Supply Encoder Sensor has unexpectedly stop receiving information from the Ribbon Encoder • LCD Error Display: Ribbon BreakJam • Driver Monitor Error Display: Ribbon BreakJam

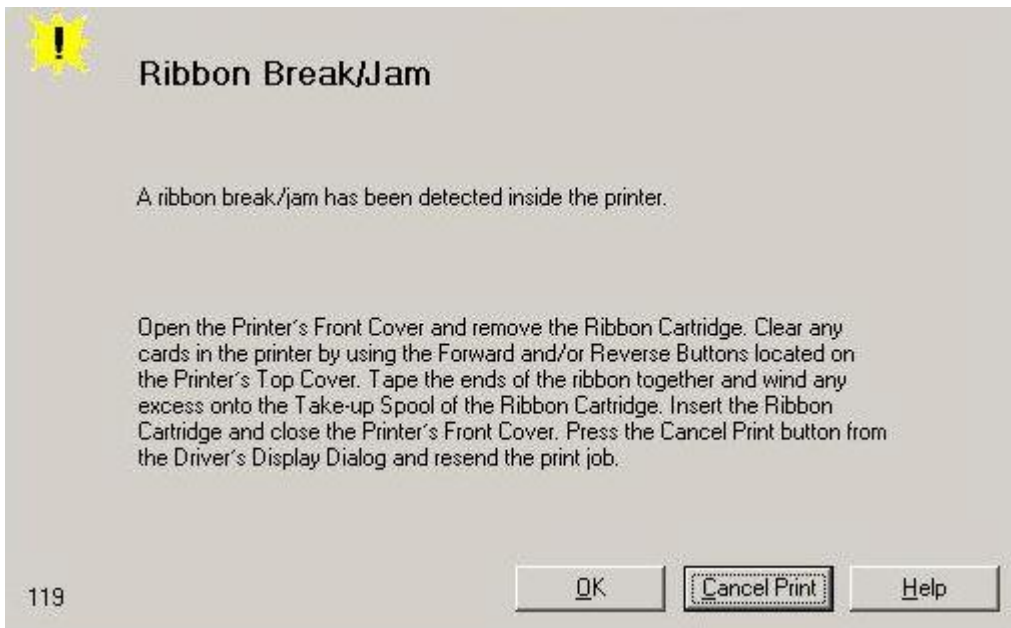

Resolving a Ribbon Break Jam Error (continued)

Step	Procedure
2	Open the front cover and remove the Ribbon Cartridge. <ul style="list-style-type: none"> • If Ribbon is broken, continue to Step 3. • If Ribbon is in good condition, continue to Step 6.
3	Adjust the print offset. See the Using the Print Top of Form Option procedure. If the issue persists, continue to Step 4.
4	Repair the Ribbon and wind up the take-up roll 4 color panels past the damage area. <ol style="list-style-type: none"> a. Press on the Resume button. b. If the issue persists, continue to Step 5.
5	Use the Fargo Diagnostic utility to cycle the Printhead to ensure proper printhead operation. See the Using the Diagnostic Utility tabs procedure. <ul style="list-style-type: none"> • If the Printhead does not cycle properly, see Resolving the Headlift Motor / Sensor Error. • If the Printhead functions properly, continue to Step 6.
6	Replace the Ribbon Cartridge. <ol style="list-style-type: none"> a. Press on the Resume button. b. If the issue persists, continue to Step 7.
7	Remove the rear cover in order to check that the Ribbon Encoder Sensor is securely connected to the J-4 Main Board connection and to the Encoder Sensor. <ol style="list-style-type: none"> a. Press on the Resume button. b. If the issue persists, replace the Encoder Sensor.

Resolving a Ribbon Out Error

All Troubleshooting procedures assume that only factory-authorized supplies are in use in the Printer.

Step	Procedure
1	Review the following information. <ul style="list-style-type: none"> • Symptom: Printer will not print. • Printer Error State: The Ribbon Sensor has detected the End Of Ribbon mark • LCD Error Display: Ribbon Out • Driver Monitor Error Display: Ribbon Out
2	Replace the Ribbon Cartridge <ol style="list-style-type: none"> a. Press on the Resume button.

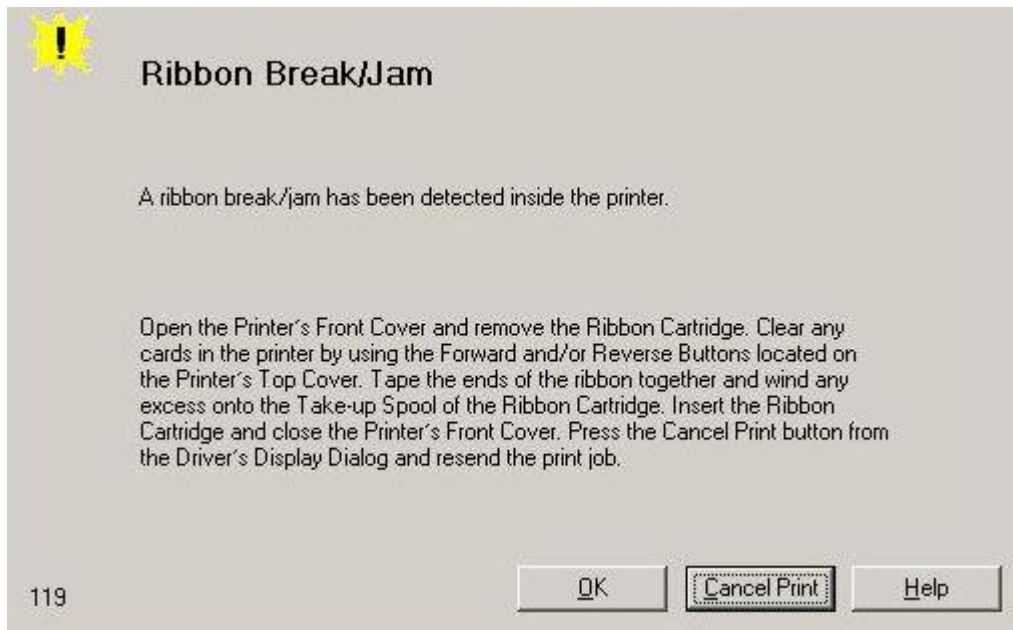

Resolving a No Ribbon Installed Error

All Troubleshooting procedures assume that only factory-authorized supplies are in use in the Printer.

Step	Procedure
1	<p>Review the following information.</p> <ul style="list-style-type: none"> • Symptom: Printer errors out as soon as it receives data from PC • Printer Error State: The Printer RFID Sensor is not receiving a signal from the Ribbon • LCD Error Display: No Ribbon • Driver Monitor Error Display: No Ribbon Installed

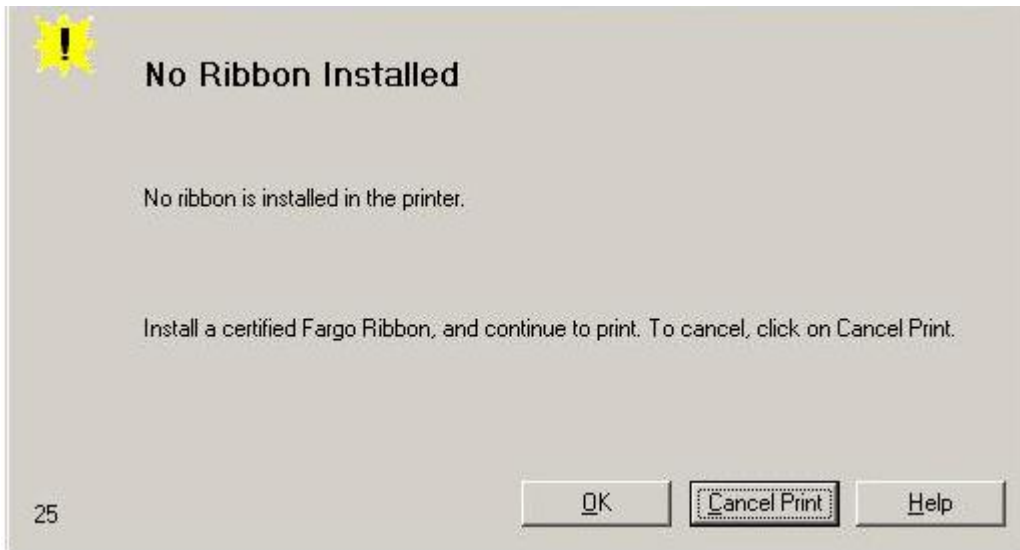

Resolving a No Ribbon Installed Error (continued)

Step	Procedure
2	Verify that a Ribbon Cartridge is installed in the Printer. a. Press on the Resume button. b. If the issue persist, continue to Step 3.
3	Remove the rear cover and check that the Ribbon RFID cable is securely connected to the Main Board (J-5) and the RFID Sensor. <ul style="list-style-type: none">• If the connections are loose, reattach them.• Press on the Resume button.• If the connections are good or if the issue persists, continue to Step 4.
4	Replace the Ribbon RFID Sensor.

Resolving a Invalid Ribbon Error

All Troubleshooting procedures assume that only factory-authorized supplies are in use in the Printer.

Step	Procedure
1	<p>Review the following information.</p> <ul style="list-style-type: none"> • Symptom: Printer errors out as soon as it receives data from the PC • Printer Error State: The Ribbon installed does not match the Printer model. • LCD Error Display: Invalid Ribbon • Driver Monitor Error Display: Invalid Ribbon

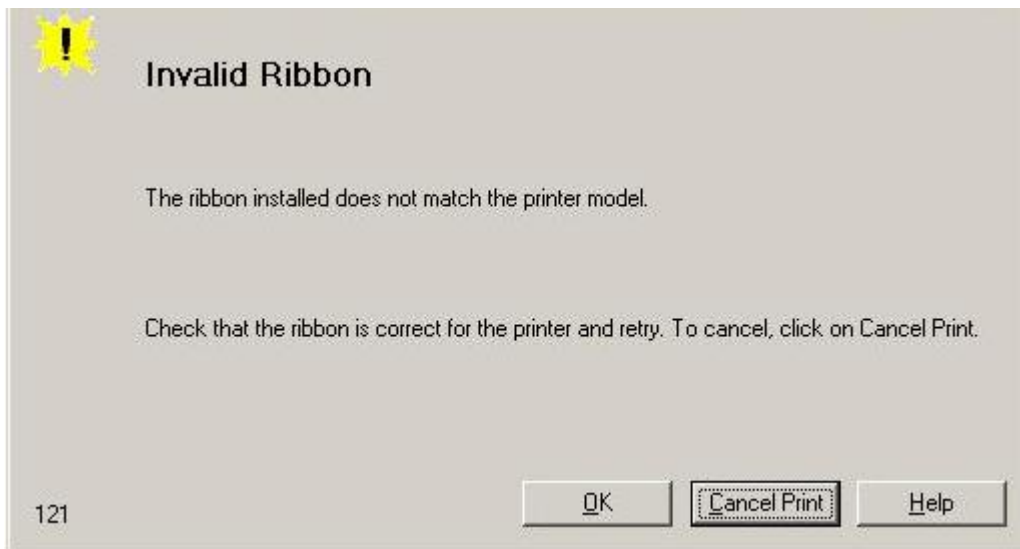

Resolving a No Ribbon Installed Error (continued)

Step	Procedure
2	Verify that the Ribbon Cartridge installed is designed for the correct Printer model.
3	Press on the Resume button. If the issue persists, continue to Step 4.
4	Remove the rear cover and check that the Ribbon RFID cable is securely connected to the Main Board (J-5) and the RFID Sensor. <ul style="list-style-type: none">• If the connections are loose, reattach• Press on the Resume button..• If the connections are good or if the issue persists, continue to Step 5.
5	Replace the Ribbon RFID Sensor.

Resolving a Wrong Ribbon Error

All Troubleshooting procedures assume that only factory-authorized supplies are in use in the Printer.

Step	Procedure
1	<p>Review the following information.</p> <ul style="list-style-type: none">• Symptom: Printer errors out as soon as it receives data from the PC• Printer Error State: The Ribbon installed does not match the Printer Driver information• LCD Error Display: Wrong Ribbon• Driver Monitor Error Display: Wrong Ribbon

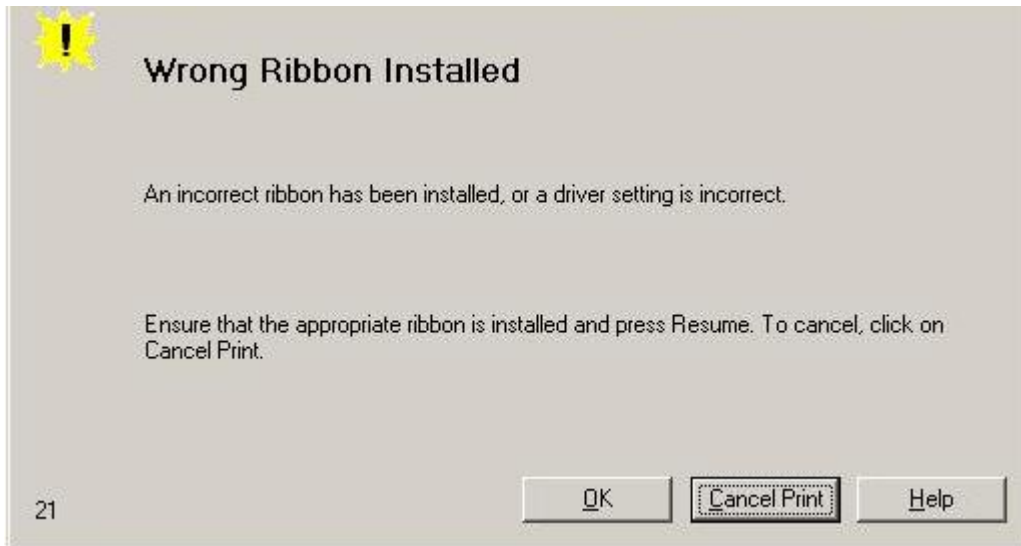

Resolving a Wrong Ribbon Error (continued)

Step	Procedure
2	Verify the Driver settings are correct. <ol style="list-style-type: none"> a. Open the Printer Control Panel from the Computer. <ul style="list-style-type: none"> • If using Windows 98SE, Me, right click on the DTC300/DTC300M Card Printer Icon and select Properties. • If using Windows 2000/XP, right click on the DTC300/DTC300M Card Printer and select Printing Preferences. b. Click on the Device Option tab. c. Click on the auto select button. d. Check that the Ribbon type matches the Ribbon selected.
3	Press on the Resume button. If the issue persists, continue to Step 4.
4	Remove the rear cover and check that the Ribbon RFID cable is securely connected to the Main Board (J-5) and the RFID Sensor. <ul style="list-style-type: none"> • If the connections are loose, reattach it. • Press on the Resume button. • If the connections are good or if the issue persists, continue to Step 5.
5	Replace the Ribbon RFID Sensor.

Resolving a Card Jam Error

All Troubleshooting procedures assume that only factory-authorized supplies are in use in the Printer.

Step	Procedure
1	<p>Review the following information.</p> <ul style="list-style-type: none"> • Symptom: Card is jammed. • Printer Error State: Card TOF Sensor is detecting no card motion • LCD Error Display: Card Jam • Driver Monitor Error Display: Card Jam

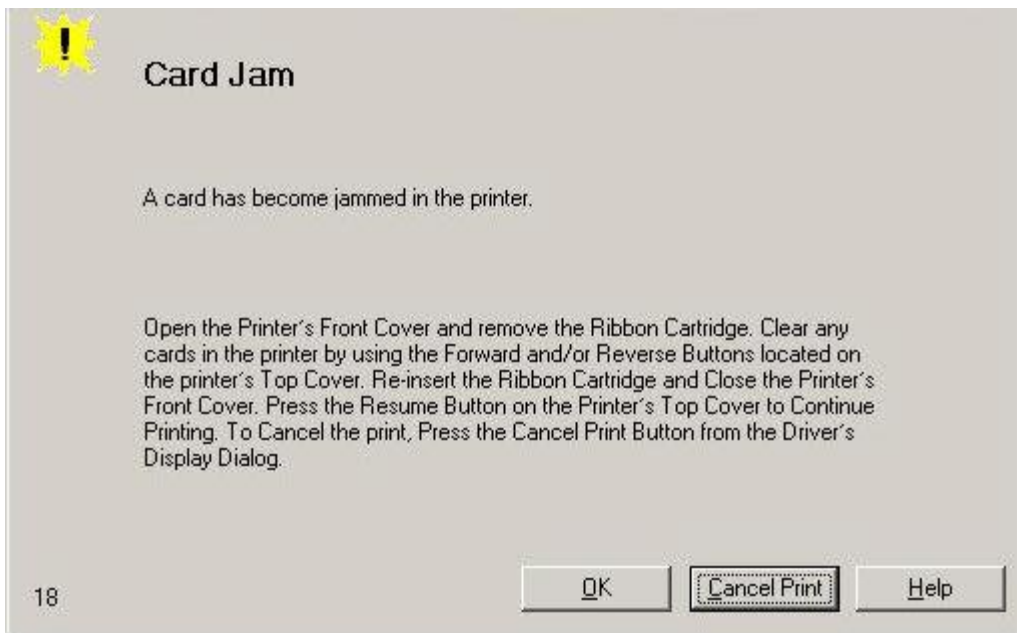

Resolving a Wrong Ribbon Error (continued)

Step	Procedure
2	<p>Look for a jammed card in the Printer.</p> <ol style="list-style-type: none"> a. Open the Printer's front cover. b. Remove the Ribbon Cartridge from the Printer. c. Check to see if a card is jammed in the print station of the Printer. d. If a card is found in the print station, continue to Step 3. e. If no card was found in the print station, continue to Step 4.
3	<p>Clearing a jammed card.</p> <ol style="list-style-type: none"> a. If a card is jammed in the Printer, use the Cancel button and the Pause button to move the Feed Rollers and free the card. b. The card can then be fed out of the Printer.
4	<p>Test the Card Sensor.</p> <ol style="list-style-type: none"> a. Remove the rear cover. b. Using a Digital Voltmeter, connect the negative lead to ground. c. Connect the positive lead to Pin 10 of J4. <ul style="list-style-type: none"> • If blocked, the Sensor should read 4.9 to 5.5 VDC. • If unblocked, the Sensor should read 0.15 to 0.18 VDC. d. If the voltages do not read correctly, replace the Sensor. (Note: See the current DTC300/DTC300M User Guide for related instructions in the Parts Replacement Section.)

Resolving a Headlift Motor or Sensor Error

All Troubleshooting procedures assume that only factory-authorized supplies are in use in the Printer.

Step	Procedure
1	<p>Review the following information.</p> <ul style="list-style-type: none"> • Symptom: The Printhead continuously cycles or does not cycle at all • Printer Error State: Headlift Sensor is not detecting movement from the Headlift Cam • LCD Error Display: Head Lift Error • Driver Monitor Error Display: General Error

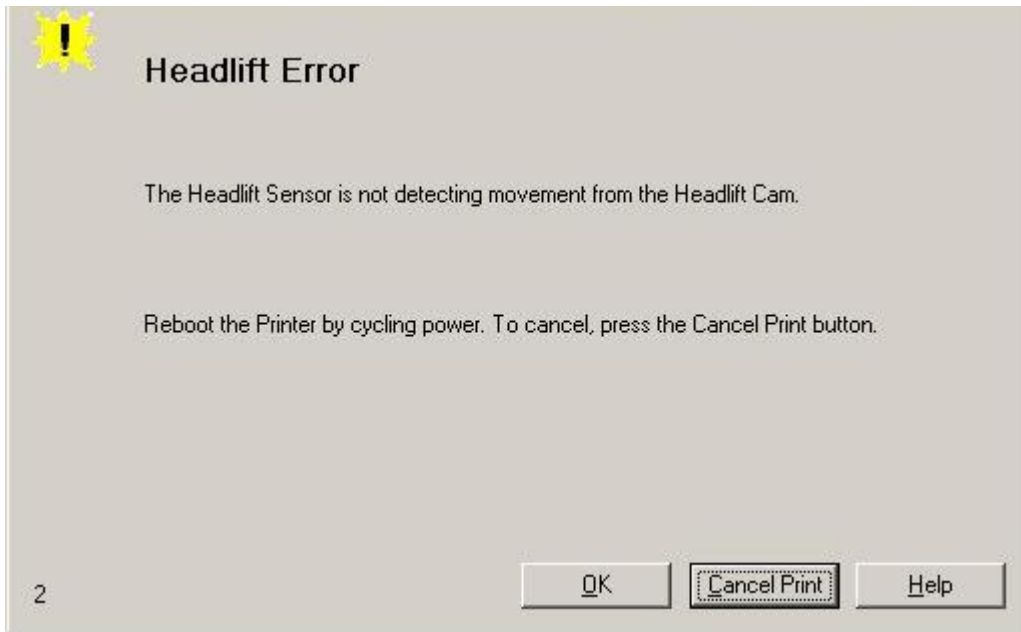

Resolving a Headlift Motor or Sensor Error (continued)

Step	Procedure
2	Press the Cancel Print button on the Driver Monitor Error Display Message.
3	Reboot the Printer by cycling the power.
4	<p>Cycle the Headlift Motors.</p> <ol style="list-style-type: none"> Use the Fargo Diagnostic utility to cycle the Printhead to ensure proper printhead operation. See the Using the Diagnostic Utility tabs. Verify that the Headlift Motor turns. If the Motor does not turn or jams, continue to Step 5.
5	<p>Check the Headlift Motor Main Board Connection (J20).</p> <ol style="list-style-type: none"> Unplug the Printer. Remove the back cover. Verify that connection J20 is properly connected to the Main Board. If the Motor does not turn, continue to Step 7.
6	<p>Test the Headlift Sensor.</p> <ol style="list-style-type: none"> Remove the back cover. Attach the positive lead from a Digital Voltmeter to Pin 1 of J9. Attach the negative lead to the Pin 3 of J9. <ul style="list-style-type: none"> • If open, the Sensor should read 0.17 to 0.9 VDC. • If closed, the Sensor should read 4.9 to 5.5 VDC. Replace the Sensor if the voltages do not read correctly. (Note: See the current DTC300/DTC300M User Guide for related instructions in the Parts Replacement Section.) If the Motor does turn, continue to Step 7.
7	<p>Replace the Headlift Motor. (Note: See the current DTC300/DTC300M User Guide for related instructions in the Parts Replacement Section.)</p> <ol style="list-style-type: none"> If the Motor does turn, continue to Step 8.
8	Replace the Main Board.

Resolving the Cover Open Error Message

All Troubleshooting procedures assume that only factory-authorized supplies are in use in the Printer.

Step	Procedure
1	Review the following information. <ul style="list-style-type: none"> • Symptom: The Printer errors immediately after sending a print job, or the Rollers do not operate by pressing the cottons on the front panel (when the cover is open). • Printer Error State: The front cover Sensor detects that the cover is open • LCD Error Display: Cover Open • Driver Monitor Error Display: None
2	Check for debris, as follows: <ol style="list-style-type: none"> a. Open the front cover and check that no debris has accumulated in the lid Sensor opening. Use compressed air to clean the opening id as needed. b. If the Sensor still does not work, continue to Step 3.
3	Check that the Sensor tab on the front cover is not damaged. <ol style="list-style-type: none"> a. Open the front cover and examine the Lid Sensor tab for damage, if the Sensor tab is damaged, replace the front cover. (Note: See the current DTC300/DTC300M User Guide for related instructions in the Parts Replacement Section.) b. If the Sensor still does not work, continue to Step 4.
4	Replace the Main Board. (Note: See the current DTC300/DTC300M User Guide for related instructions in the Parts Replacement Section.)

Resolving the Blank Output issues

All Troubleshooting procedures assume that only factory-authorized supplies are in use in the Printer.

Step	Procedure
1	Review the following information. <ul style="list-style-type: none"> • Symptom: A card is ejected blank (that should be printed). • Printer Error State: None • LCD Error Display: None • Driver Monitor Error Display: None
2	Run a self-test. <ol style="list-style-type: none"> a. Clear any card jams. b. Unplug power from the Printer. c. While holding down the Pause button, reapply power. <p>(Note: A self-test card will be printed.)</p>
3	Look for an image on the Ribbon. <ol style="list-style-type: none"> a. After a self-test has been run, open the top cover. b. Remove the Print Ribbon from the Printer. c. Visually inspect the set of panels that were last used by the Printer. d. If an image is noticeable on the used Ribbon, continue to Step 4. e. If an image is not noticeable on the used Ribbon, continue to Step 5.

Resolving the Blank Output issues (continued)

Step	Procedure
4	<p>Adjust the placement.</p> <ol style="list-style-type: none"> a. Reset the Printer to clear any Error Messages by removing the power and reapplying it. b. Open the Printer Control Panel from the Computer. <ul style="list-style-type: none"> • If using Windows 98SE, Me, right click on the DTC300/DTC300M Card Printer Icon and select Properties. • If using Windows 2000/XP, right click on the DTC300/DTC300M Card Printer and select Printing Preferences. c. Click on the Calibrate tab. d. Click on the Settings button. e. Adjust the Image Placement Setting by +5. f. Click on the OK button. g. Print a self-test. h. After adjusting the Image Placement, if a white border appears on the card, adjust the image placement back toward its original value in increments of 2 until the white edge is gone. i. If still having blank card issues, continue to Step 5.
5	<p>Check the Printhead connections.</p> <ol style="list-style-type: none"> a. Remove the Printer power and USB cables. b. Turn the Printer over to gain access to the base plate. c. Remove the one (1) thumbscrew from the Printhead cover plate and remove the cover plate. d. Depress the Printhead locking tabs and remove the Printhead. e. Check to ensure that Power and Data Cables (that connect to the Printhead) are properly seated. f. Remove the Back Cover. g. Ensure that the Printhead Power/Data Cable is properly seated on J16 on the Main board. h. If still having blank card issues, continue to Step 6.

Resolving the Blank Output issues (continued)

Step	Procedure
6	<p>Ensure that the proper voltage is being applied to the Printhead.</p> <ol style="list-style-type: none">a. Remove the back cover.b. Using a Digital Voltmeter, connect the negative lead to ground.c. Probe Pins 1 to 5 of the Printhead power connection on J16.d. Ensure that a voltage between 22 to 23 VDC is read on each pin.<ul style="list-style-type: none">• If less than 22 volts is read on any of the pins, replace the Printhead.• If still having issue with blank cards, replace the Main Board. (See the current DTC300/DTC300M User Guide for instructions on replacing the Main Board in the Parts Replacement Section.)

Flipper Table Module Assembly Problems

Resolving the No Flipper Table Module problem

All Troubleshooting procedures assume that only factory-authorized supplies are in use in the Printer. See the [Flipper Table Module Installation](#) section (as needed).

Step	Procedure
1	<p>Review the following information.</p> <ul style="list-style-type: none"> • Symptom: The Flipper Table Module Assembly is not functioning. • Printer Error State: The Printer is unable to communicate with the Flipper Module. • LCD Error Display: No Flip Installed • Driver Monitor Error Display: No Flipper Module

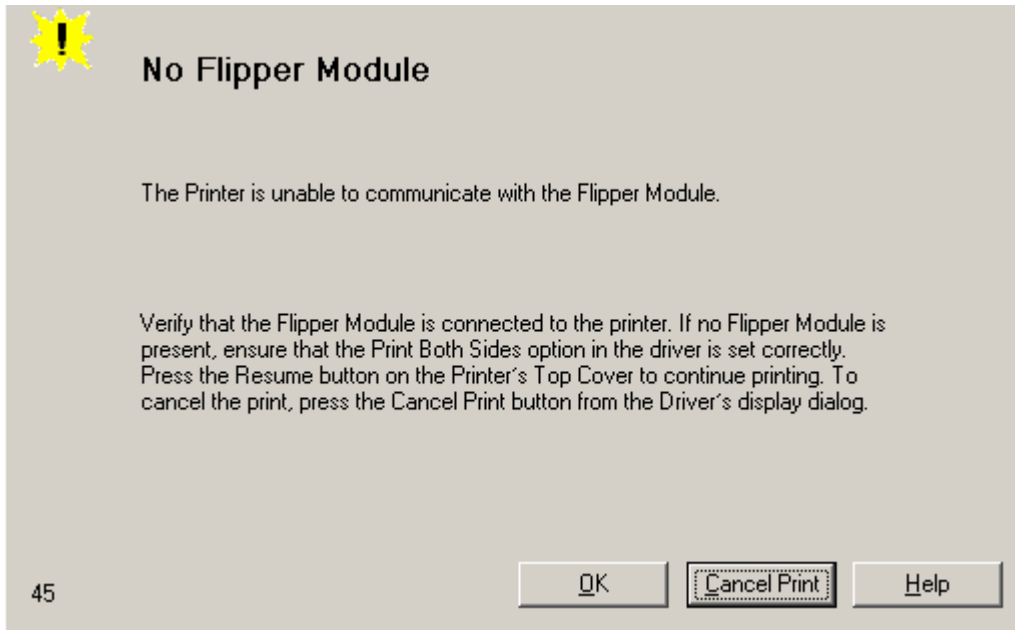

Resolving the Flipper Jam Error

All Troubleshooting procedures assume that only factory-authorized supplies are in use in the Printer. See the [Flipper Table Module Installation](#) section (as needed).

Step	Procedure
1	<p>Review the following information.</p> <ul style="list-style-type: none"> • Symptom: The Flipper Table Module is jamming. • Printer Error State: The Flipper Table has jammed while either aligning itself or flipping a card. • LCD Error Display: Flipper Jam • Driver Monitor Error Display: Flipper Jam

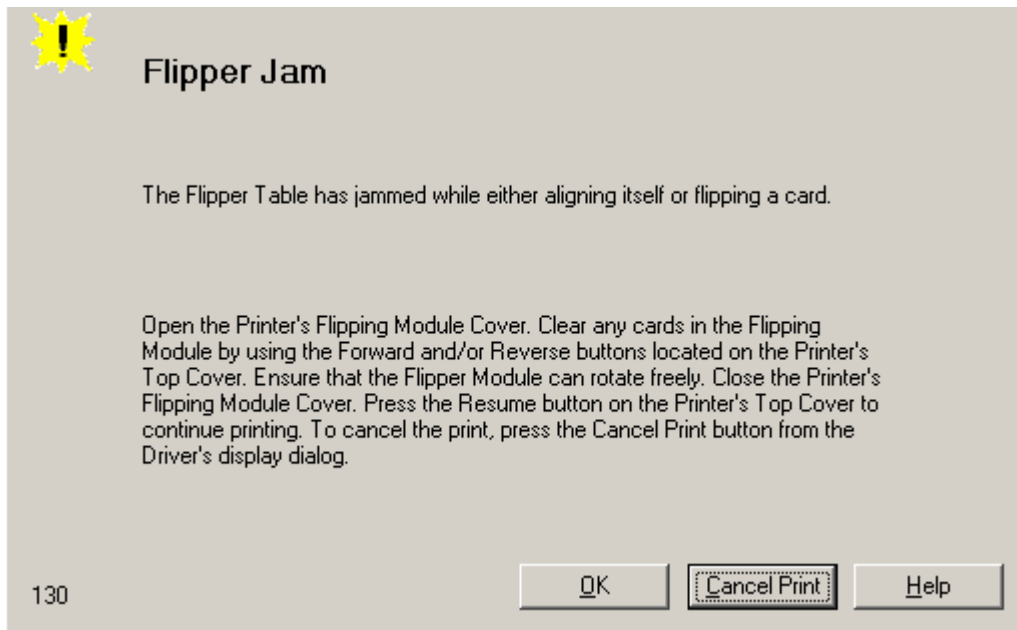

Resolving the Flipper Jam Error (continued)

Step	Procedure
2	<p>Open the Printer's Flipper Table Module Cover.</p> <ol style="list-style-type: none"> a. Clear any cards in the Flipper Table Module by using the Forward and/or Reverse buttons located on the Printer's Top Cover. b. Ensure that the Flipper Table Module can rotate freely. c. Close the Printer's Flipper Table Module. d. Press the Resume button on the Printer's Top Cover to continue printing. e. To cancel the printing, press the Cancel Print button from the Driver's display dialog.

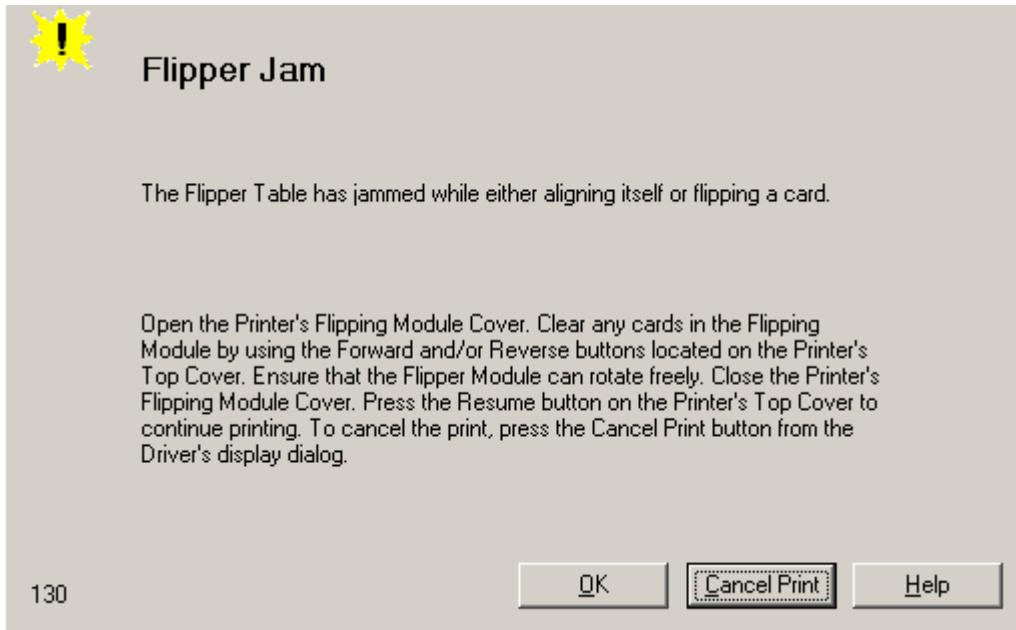

Diagnosing Image Problems

Resolving the Pixel Failure problems

All Troubleshooting procedures assume that only factory-authorized supplies are in use in the Printer.

Step	Procedure
1	<p>Review the following information.</p> <ul style="list-style-type: none"> • Symptom: A thin line or scratch travels the entire length of the card (See sample image below). • Printer Error State: None • LCD Error Display: None • Driver Monitor Error Display: None
2	Check the card stock for scratches. Replace the cards (as needed).
3	Examine the Printhead for visible damage.
4	Clean the Printhead. See the Cleaning the Printhead procedure.
5	Replace the Printhead if the problem persists. See Replacing the Printhead Assembly (D900023) .



Resolving the Card Surface Debris problems

All Troubleshooting procedures assume that only factory-authorized supplies are in use in the Printer.

Step	Procedure
1	<p>Review the following information.</p> <ul style="list-style-type: none"> • Symptom: Prints have spots (white or colored voids) and/or dust on them (See sample image below). • Printer Error State: None • LCD Error Display: None • Driver Monitor Error Display: None
2	Ensure the cards are clean and stored in a dust-free environment. Do not use cards with embedded contaminants in the surface.
3	Clean the inside of the Printer. See Cleaning the Printer's Interior .
4	Clean the Cleaning Roller. See Cleaning the Card Feed and Cleaning Rollers .



Resolving the Incorrect Image Darkness problems

All Troubleshooting procedures assume that only factory-authorized supplies are in use in the Printer.

Step	Procedure
1	Review the following information. <ul style="list-style-type: none"> • Symptom: Printed cards are too dark or too light. • Printer Error State: None • LCD Error Display: None • Driver Monitor Error Display: None
2	Run a self-test to ensure that the issue is not with the Driver settings.
3	Adjust the Dye-Sub Intensity setting within the Image Color tab of the Printer Driver. See Using the Image Color tab (DTC300/DTC300M) procedure.

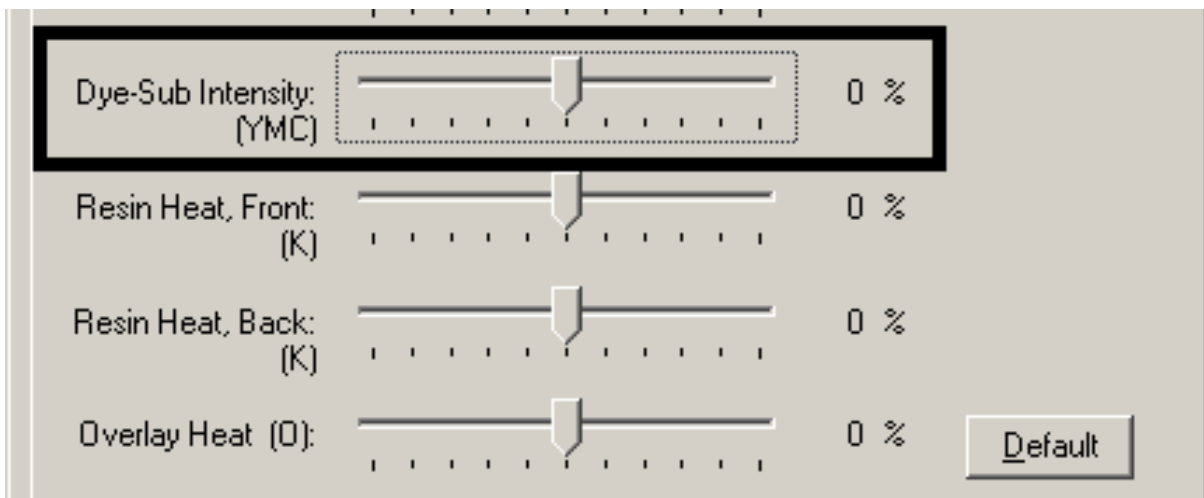

Resolving the Incorrect Image Darkness problems (continued)

Step	Procedure
4	Correct the Image Darkness . See the Using the Image Darkness Option procedure.



Resolving Ribbon Wrinkle problems

All Troubleshooting procedures assume that only factory-authorized supplies are in use in the Printer.

Step	Procedure
1	Review the following information. <ul style="list-style-type: none"> • Symptom: Printed cards have off-colored lines or streaks on them. • Printer Error State: None • LCD Error Display: None • Driver Monitor Error Display: None
2	Confirm that the Printer is using the most current Driver via: http://www.fargo.com
3	Reduce the Dye-Sub Intensity setting within the Image Color tab of the Printer Driver. See the Using the Image Color tab (DTC300/DTC300M) .

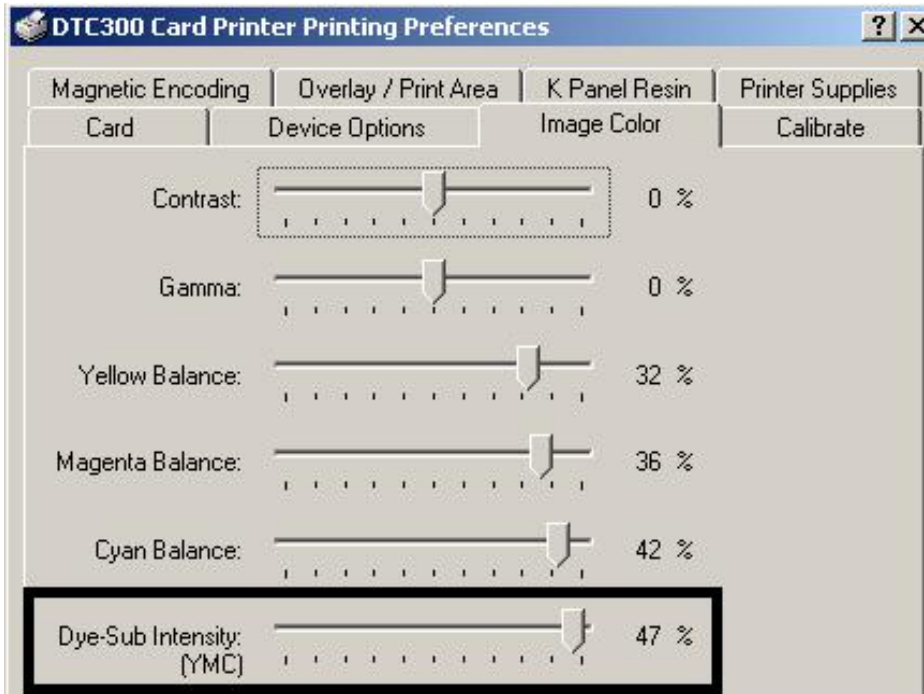

Resolving Ribbon Wrinkle problems (continued)

Step	Procedure
4	Reduce the Image Darkness. See the Using the Image Darkness Option procedure.



Resolving the Excessive Resin Printing problems

All Troubleshooting procedures assume that only factory-authorized supplies are in use in the Printer.

Step	Procedure
1	Review the following information. <ul style="list-style-type: none"> • Symptom: Black resin text and barcodes appear smeared or too thick. • Printer Error State: None • LCD Error Display: None • Driver Monitor Error Display: None
2	Reduce the Resin Heat setting within the Image Color tab of the Printer Driver. See the Using the Image Color tab (DTC300/DTC300M) .

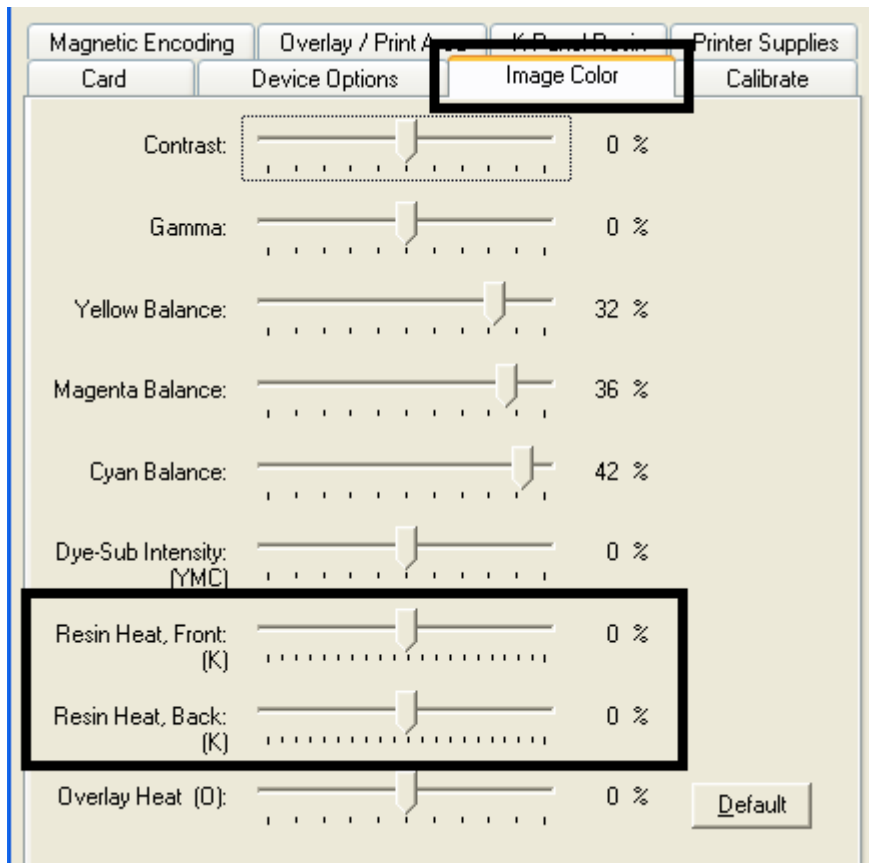

Resolving the Excessive Resin Printing problems (continued)

Step	Procedure
3	Reduce the Image Darkness. See the Using the Image Darkness Option procedure.

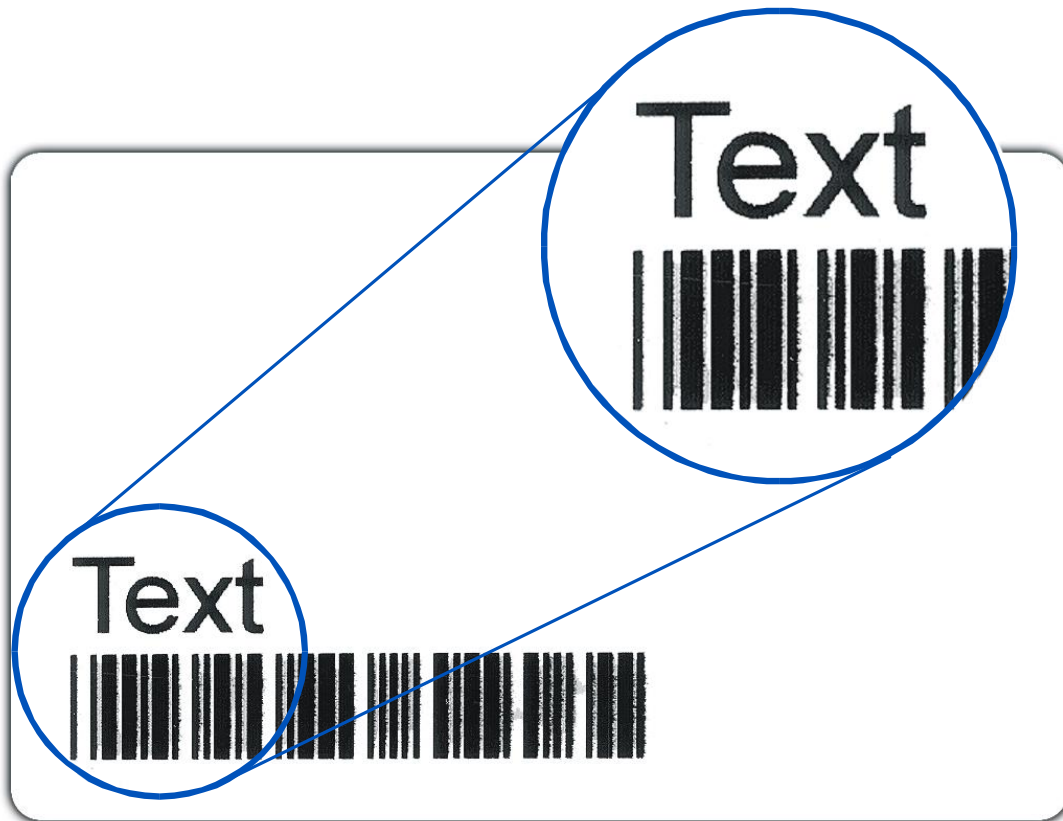

Resolving the Incomplete Resin Printing problems

All Troubleshooting procedures assume that only factory-authorized supplies are in use in the Printer.

Step	Procedure
1	Review the following information. <ul style="list-style-type: none"> • Symptom: Black resin text and barcodes appear faded or too light. • Printer Error State: None • LCD Error Display: None • Driver Monitor Error Display: None
2	Increase the Resin Heat setting within the Image Color tab of the Printer Driver. See the Using the Image Color tab (DTC300/DTC300M) .
3	Increase the Image Darkness . See the Using the Image Darkness Option procedure.

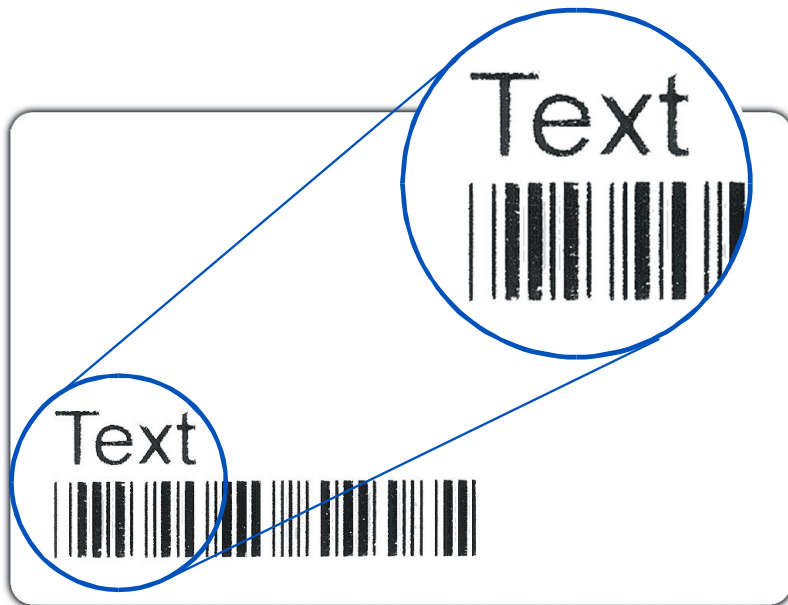

Resolving the Image Placement problems

All Troubleshooting procedures assume that only factory-authorized supplies are in use in the Printer. This procedure is used to adjust the position of the card in the Print driver and does not change the internal settings of the Printer. See [Using the Printer Calibration Utility \(DTC300/DTC300M\)](#) for instructions on changing the Printers internal settings.

Step	Procedure
1	<p>Review the following information.</p> <ul style="list-style-type: none"> • Symptom: Printing is cut off or is not centered on the card, or a white border appears. • Printer Error State: None • LCD Error Display: None • Driver Monitor Error Display: None
2	<p>Verify if the Image Position option within the Calibrate tab is set correctly or incorrectly.</p> <ol style="list-style-type: none"> a. Open the Printer Control Panel from the Computer. <ul style="list-style-type: none"> • If using Windows 98SE, Me, right click on the DTC300/DTC300M Card Printer Icon and select Properties. • If using Windows 2000/XP, right click on the DTC300/DTC300M Card Printer and select Printing Preferences. b. Click on the Calibrate tab. c. Adjust the Vertical and/or Horizontal Image Position settings based on where the white border is on the card.

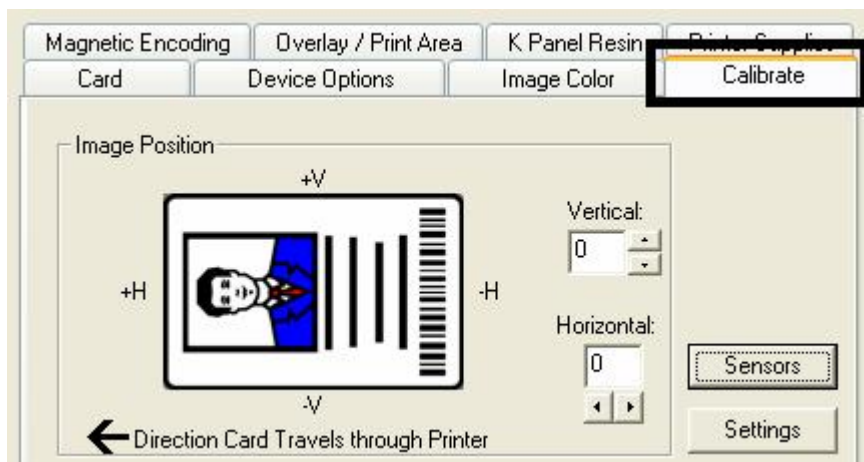

Resolving the Image Placement problems (continued)

Step	Procedure
3	<p>Verify if the Horizontal Image Position Setting is set correctly or incorrectly. See the graphic below.</p> <ul style="list-style-type: none">• If the white border is on the leading edge of the card, adjust the Horizontal value by +2.• If the white border is on the trailing edge of the card, adjust the Horizontal value by -2. <ol style="list-style-type: none">a. Click on OK.b. Run a self-test.c. If the white border is diminished, continue the adjustment until it is gone.

Graphic A

Resolving the Image Placement problems (continued)

Step	Procedure
4	<p>Verify if the Vertical Image Position Setting is set correctly or incorrectly. See the graphic below.</p> <ul style="list-style-type: none">• If the white border is on the top edge of the card, adjust the Vertical value by +2.• If the white border is on the bottom edge of the card, adjust the Vertical value by -2. <ol style="list-style-type: none">a. Click on OK.b. Run a self-test.c. If the white border is diminished, continue the adjustment until it is gone.

Graphic B

Resolving the Poor Image Quality problems

All Troubleshooting procedures assume that only factory-authorized supplies are in use in the Printer.

Step	Procedure
1	Review the following information. <ul style="list-style-type: none"> • Symptom: Photos on the cards look pixilated or grainy, as shown below. • Printer Error State: None • LCD Error Display: None • Driver Monitor Error Display: None
2	Use high-resolution, 24-bit color images to always capture an image: <ul style="list-style-type: none"> • at a 24-bit color setting • at 300 dpi • at the same size that it will be printed on the card, as captured either with a scanner or with a digital camera If a small or low-resolution image is stretched or blown up, a pixilated or grainy effect will occur when printing, as shown below (rightside).



Good



Bad

Running the Self Test

Perform a self-test after (a) an initial setup of the Printer, (b) a calibration procedure has been conducted, or (c) a part has been replaced to check for proper Printer operation.

Step	Procedure
1	Verify that a full-color or Premium Resin Ribbon Cartridge is installed and that cards are properly loaded.  Caution: If the power is ON, disconnect the Power Cable from the Printer's rear panel.
2	Press and hold the Pause/Resume button.
3	While holding down the Pause/Resume button, plug the power cable back into the Printer.
4	<ul style="list-style-type: none"> • Full Color Ribbon Cartridge installed: The Printer will print a 3-color process gray scale on the front of the card. The overlay pass is not printed during the Self-test. (See Display A below) • Premium Resin Ribbon Cartridge installed: The Printer will print a single color gray scale on the front of the card. See Display B below)

Running the Standard Self Test Print

Display A - Full Color Test Print

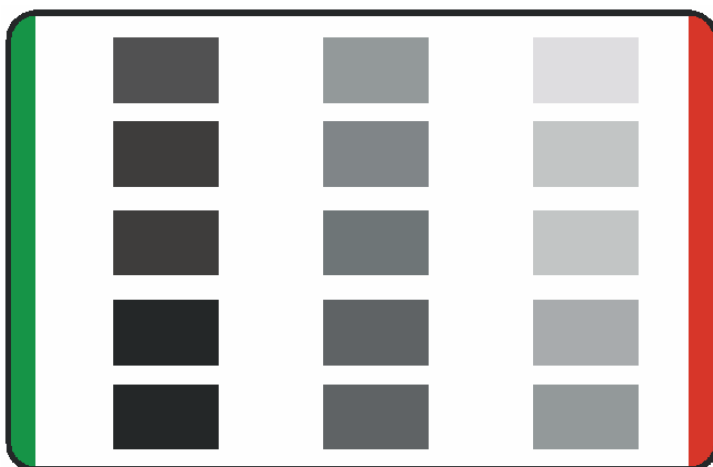

Running the Magnetic Self Test (HiCo Only)

Perform a self-test after (a) an initial setup of the Printer, (b) a calibration procedure has been conducted, or (c) a part has been replaced to check for proper Printer operation.

Step	Procedure
1	Remove Ribbon Cartridge from the Printer and close the front cover  Caution: If the power is ON, disconnect the Power Cable from the Printer's rear panel.
2	Press and hold the Pause/Resume button.
3	While holding down the Pause/Resume button, plug the power cable back into the Printer.
4	The Printer will Encode magnetic information on all 3 magnetic tracks

Section 5: Printer Adjustments

See this section for Printer adjustments.



Table of Contents

Section 5: Printer Adjustments	5-1
Table of Contents	5-1
Safety Messages (review carefully)	5-4
DTC300/DTC300M Print Driver Options	5-5
Reviewing DTC300 and DTC300M Printer Drivers	5-5
Reviewing DTC300 Printer Driver	5-5
Reviewing DTC300M Printer Drivers	5-6
Using the Card tab	5-7
Adjusting the Card Size Option	5-7
Adjusting the Orientation Option	5-8
Selecting the number of copies	5-9
Using the Diagnostics button under the Card tab	5-10
Using the Clean Printer Option	5-11
Using the Clean Printer Option (Continued)	5-12
Using the Test Print button	5-13
Using the About button	5-14
Using the Device Options tab (DTC300)	5-15
Adjusting the Ribbon Type option	5-16
Selecting the Auto Ribbon Select option	5-17
Using the new Printer Driver (Rev. 2.1.5)	5-18
Changing the Color Profile Selection for the DTC300	5-18
Changing the Color Profile Selection for the DTC300 (continued)	5-19
Adjusting the Color Matching option	5-20
Adjusting for the Resin Dither	5-21
Using the Print Both Sides option	5-22
Using the Split 1 Set of Ribbon Panels option	5-23
Using the Print Back Side First option	5-24
Using the Print Back Side Only option	5-25
Using the Rotate Image 180 Degrees option	5-26
Using the Disable Printing option	5-27
Using the Device Options tab (DTC300M)	5-28
Adjusting the Ribbon Type option	5-28
Selecting the Auto Ribbon Select option	5-29
Adjusting for the Resin Dither	5-30
Using the Rotate Image 180 Degrees option	5-31
Using the Disable Printing option	5-32
Using the Resin Heat (K) option	5-33
Using the Overlay Heat (O) option	5-34
Using the Image Color tab (DTC300)	5-35
Using the Resin Heat (K) option	5-36
Using the Overlay Heat (O) option	5-37
Using the Color Matching option and Default button	5-38
Using the Calibrate tab	5-39
Using the Image Position Controls	5-40
Using Image Position controls (continued)	5-41
Using the Sensors button	5-42
Using the Settings button	5-43
Using the Magnetic Encoding tab	5-44

Using the Magnetic Track Selection radio buttons	5-45
Using the Magnetic Track Selection radio buttons (continued)	5-46
Using the Magnetic Track Options radio buttons	5-47
Using the Bit Density radio buttons	5-48
Using the Character Size radio buttons	5-49
Reviewing the Enable MLE Support checkbox	5-50
Using the ASCII Offset radio buttons	5-51
Using the LRC Generation radio buttons	5-52
Using the Character Parity radio buttons	5-52
Using the Shift Data Left checkbox	5-53
Reviewing the ISO Track Locations	5-54
Sending the Track Information	5-55
Entering the Track Information	5-55
Reviewing Tracks 1, 2 and 3 (in table format)	5-56
Reviewing the Track Data Note	5-56
Reviewing the ASCII Code and Character Table	5-57
Using the Overlay / Print Area tab	5-58
Using the Overlay / Print Area dropdown menu	5-59
Using the Overlay / Print Area dropdown menu (continued)	5-60
Using the Overlay / Print Area	5-61
Using the Overlay / Print Area (continued)	5-62
Using the Defined Area Option	5-63
Using the Defined Area Option (continued)	5-64
Using the Defined Area Option (continued)	5-65
Using the Defined Area Option (continued)	5-66
Using the Defined Area Option (continued)	5-67
Using Security Options (Visual Security Solutions)	5-68
Selecting Orientation - Landscape under Card tab	5-69
Selecting the Visual Security Solutions dropdown menu (A to D)	5-70
Selecting Orientation - Portrait under Card tab	5-71
Selecting the Visual Security Solutions dropdown menu (E to H)	5-72
Selecting the VeriMark radio button	5-73
Selecting the HoloMark radio button	5-74
Reviewing the Custom VeriMark Card (Custom Graphic in a 2D foil)	5-75
Sample 1: VeriMark Card (Landscape - Orientation) - 4 positions (below)	5-75
Sample 2: VeriMark Card (Portrait - Orientation) - 4 positions (below)	5-75
Reviewing the Custom HoloMark Card (Custom Graphic in a 2D foil)	5-76
Sample 1: HoloMark Card (Landscape - Orientation) - 4 positions (below)	5-76
Sample 2: HoloMark Card (Portrait - Orientation) - 4 positions (below)	5-76
Using the K Panel Resin tab	5-77
Selecting from the Print All Black With K Panel options	5-78
Selecting the Full Card option	5-79
Selecting the Defined Area(s) option	5-80
Selecting the Undefined Area(s) option	5-81
Selecting the Defined Area(s) function	5-82
Selecting the Defined Area(s) function (continued)	5-83
Selecting the Defined Area(s) function (continued)	5-84
Selecting the Defined Area(s) function (continued)	5-85
Selecting the Defined Area(s) function (continued)	5-86
Selecting the Defined Area(s) function (continued)	5-87
Selecting the Defined Area(s) function (continued)	5-88
Selecting the Print YMC under K and Print K Only options	5-89
Using the Printer Supplies tab	5-90
Reviewing the Ribbon Information	5-91
Reviewing the Ribbon Level Indicator	5-92
Using the Printer Calibration Utility	5-93

Using the Image Darkness Option _____	5-94
Using the Print Top of Form Option _____	5-95
Using the Print End of Form Option _____	5-96
Using the Print Left of Form Option _____	5-97
Using the Magnetic Encoder Voltage Offset Option _____	5-98
Adjusting the Hi-Co Voltage Offset _____	5-99
Adjusting the Lo-Co Voltage Offset _____	5-100
Using the Mag Top of Form Option _____	5-101
Using the Mag Top of Form Option (continued) _____	5-102
Using the Ribbon Tension Option _____	5-103
Using the LCD Contrast Option _____	5-103

Safety Messages (review carefully)

Symbol	Critical Instructions for Safety purposes
<p>Danger:</p> 	<p>Failure to follow these installation guidelines can result in death or serious injury.</p> <p>Information that raises potential safety issues is indicated by a warning symbol (as shown to the left).</p> <ul style="list-style-type: none"> • To prevent personal injury, refer to the following safety messages before performing an operation preceded by this symbol. • To prevent personal injury, always remove the power cord prior to performing repair procedures, unless otherwise specified. • To prevent personal injury, make sure only qualified personnel perform these procedures.
<p>Caution:</p> 	<p>This device is electrostatically sensitive. It may be damaged if exposed to static electricity discharges.</p> <p>Information that raises potential electrostatic safety issues is indicated by a warning symbol (as shown to the left).</p> <ul style="list-style-type: none"> • To prevent equipment or media damage, refer to the following safety messages before performing an operation preceded by this symbol. • To prevent equipment or media damage, observe all established Electrostatic Discharge (ESD) procedures while handling cables in or near the Circuit Board and Printhead Assemblies. • To prevent equipment or media damage, always wear an appropriate personal grounding device (e.g., a high quality wrist strap grounded to avoid potential damage). • To prevent equipment or media damage, always remove the Ribbon and Cards from the Printer before making any repairs, unless otherwise specified. • To prevent equipment or media damage, take jewelry off of fingers and hands, as well as thoroughly clean hands to remove oil and debris before working on the Printer.

DTC300/DTC300M Print Driver Options

Reviewing DTC300 and DTC300M Printer Drivers

The functionality of the DTC300 and DTC300M Printer Drivers is identical. The window title reflects the specific Printer Driver in use as shown in this introductory section.

Reviewing DTC300 Printer Driver

This section applies to the DTC300 Printer.

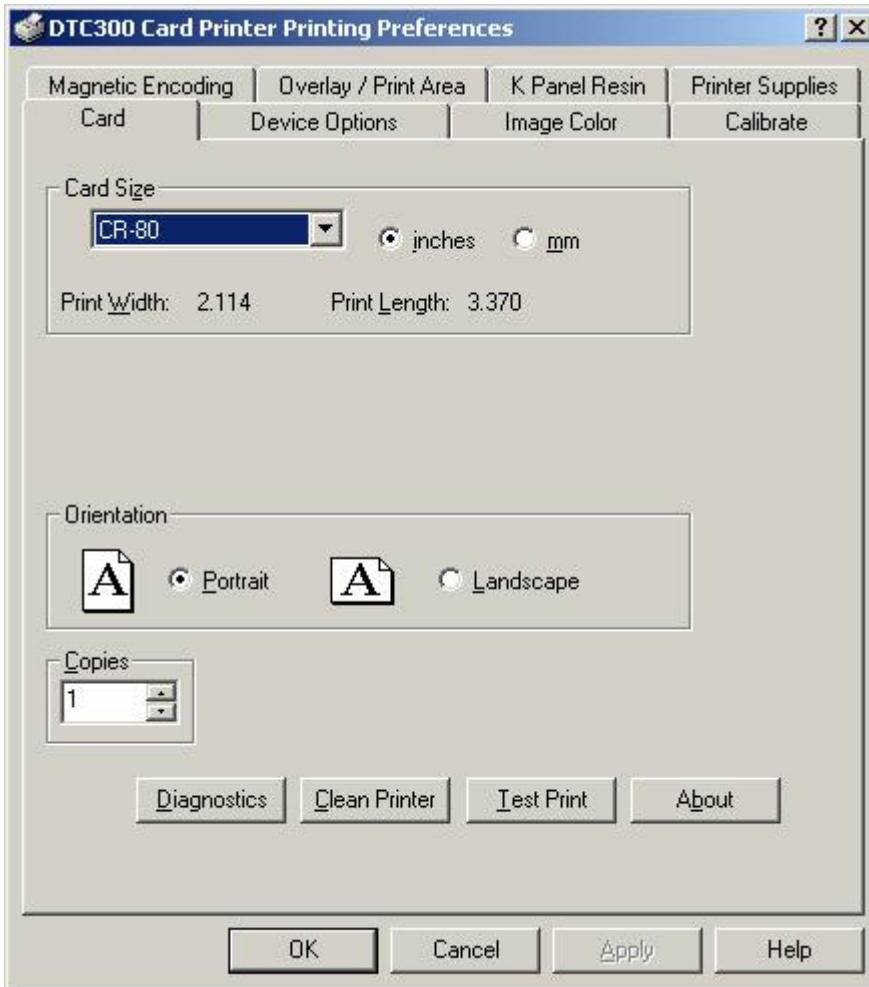

Reviewing DTC300M Printer Drivers

This section applies to the DTC300M Printer.

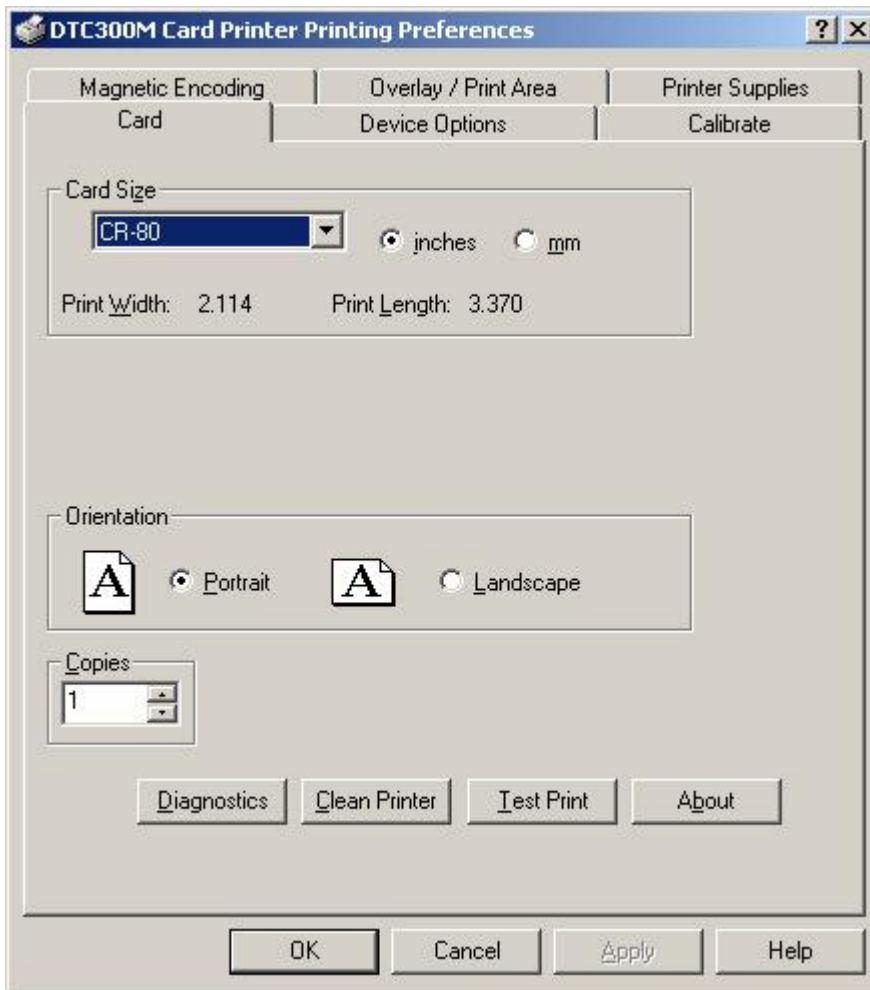

Using the Card tab

Adjusting the Card Size Option

Step	Description
1	<p>Click on the inches or mm option to choose the desired unit of measurement.</p> <p>(Note No.1: When designing a card format, always set the card size or page size within the card design program to the exact dimensions of a CR-80 card.)</p> <p>(Note No.2: The Card Size indicates that the Printer accepts standard, "credit card" size CR-80 (ISO ID-1) cards. The dimensions of the total print area for this card size appear in the Print Width and Print Length boxes.)</p>

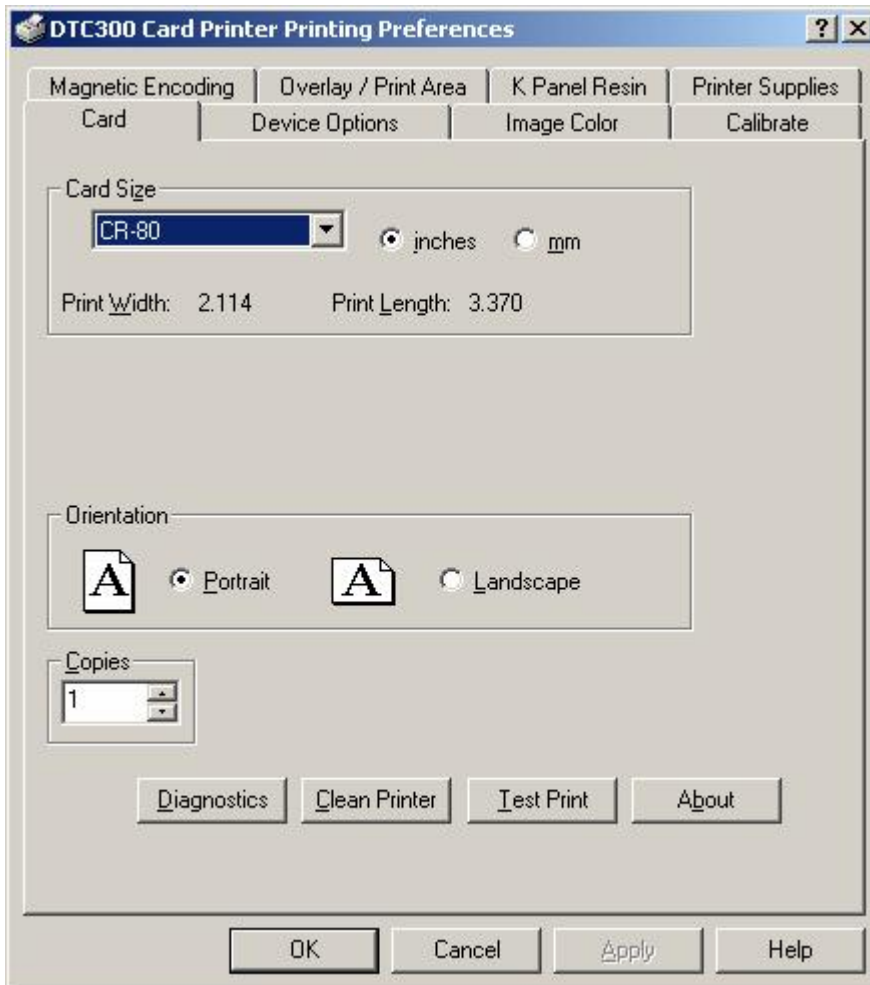

Adjusting the Orientation Option

Step	Description
1	<p>Select Portrait under Orientation to cause the card to print in a vertical orientation.</p> <p>OR</p> <p>Select Landscape under Orientation to cause the card to print in a horizontal orientation.</p> <p>(Note: An icon illustrating a printed card helps represent the difference between the two.)</p>

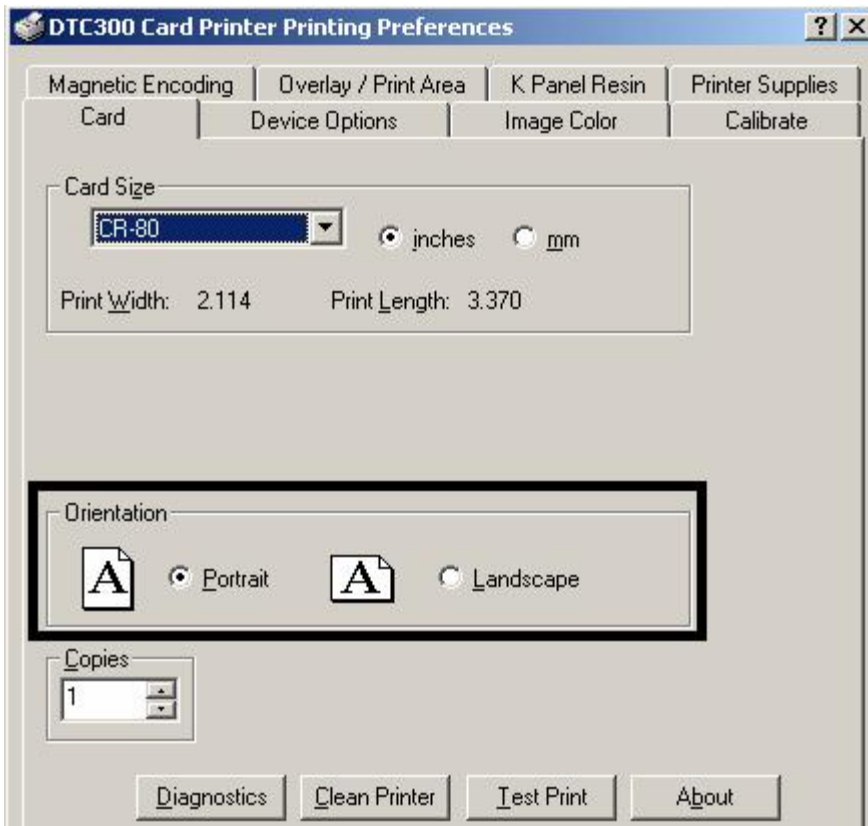

Selecting the number of copies

Step	Description
1	Select the number of copies by clicking on the UP or DOWN arrows, as shown below.

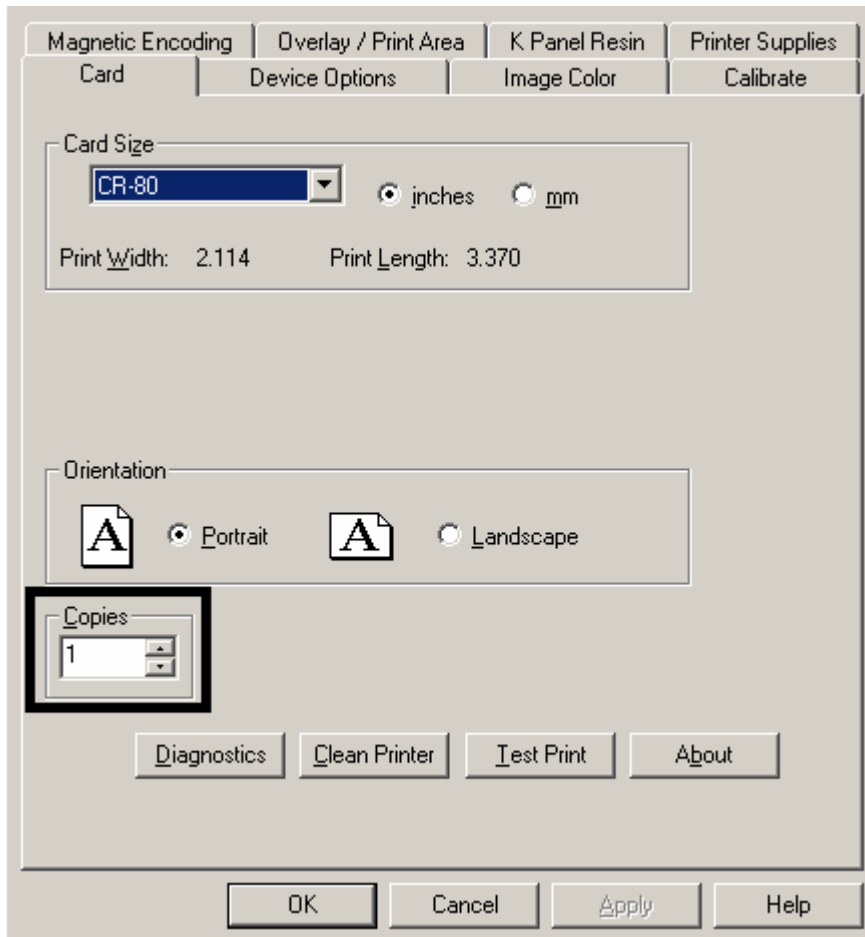

Using the Diagnostics button under the Card tab

Step	Description
1	Click on the Diagnostic button to bring up the Fargo Diagnostics Utility window. See the Section 9: Diagnostic Tool Utility .

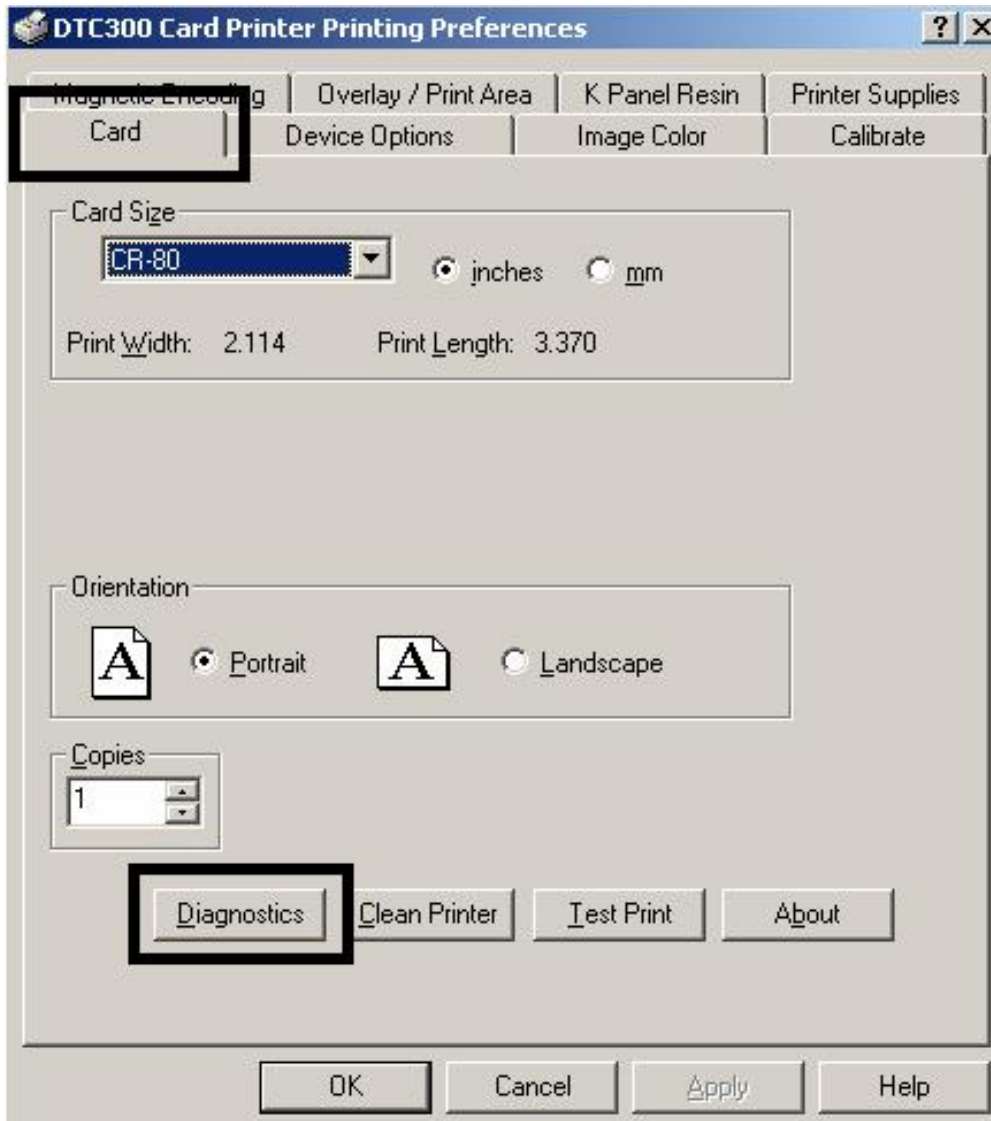

Using the Clean Printer Option

Step	Description
1	Click on the Clean Printer button to display the Clean Printer Utility window.
2	Remove all cards from the Card Hopper and close the Hopper door.
3	Open the Front Cover and remove the Ribbon Cartridge.
4	Remove the paper backing from both sides of the Cleaning Card.
5	Place the Cleaning card into the Single Feed Slot.

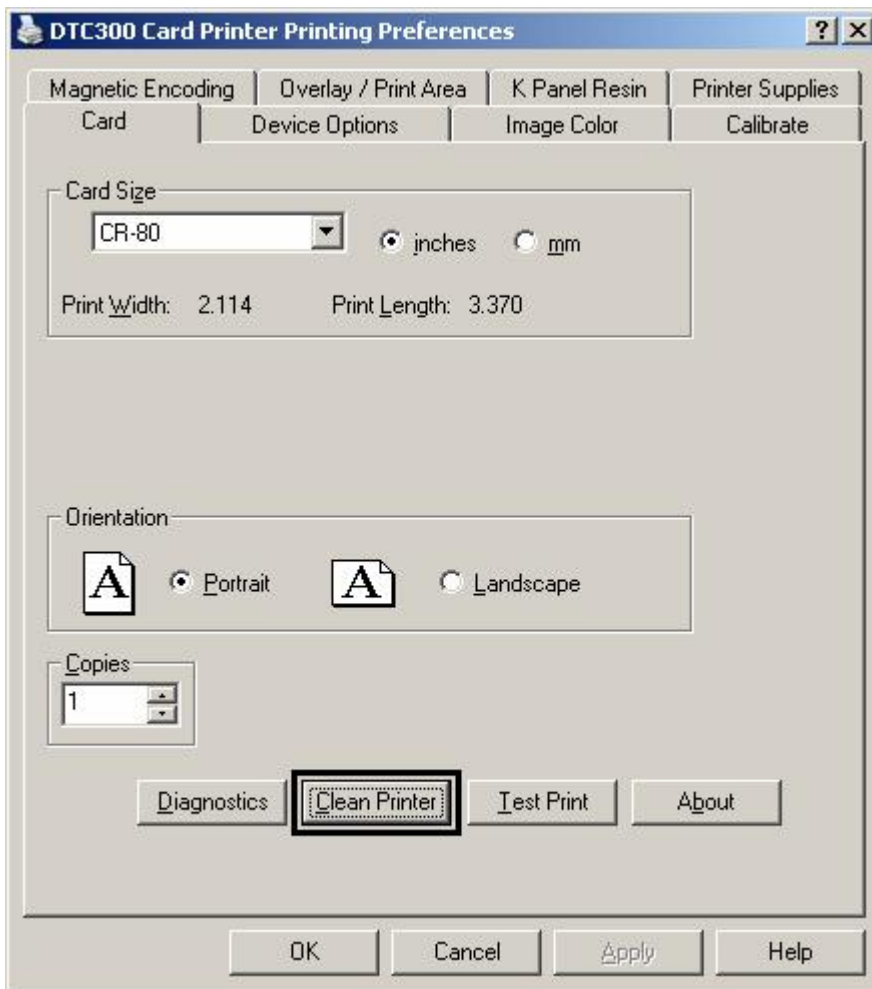

Using the Clean Printer Option (Continued)

Step	Description
6	Click on the Clean button at the bottom of the window. (Note: The Printer will begin to feed the cleaning card through the card path.)
7	Reinsert the print Ribbon and cards after the cleaning procedure has completed.

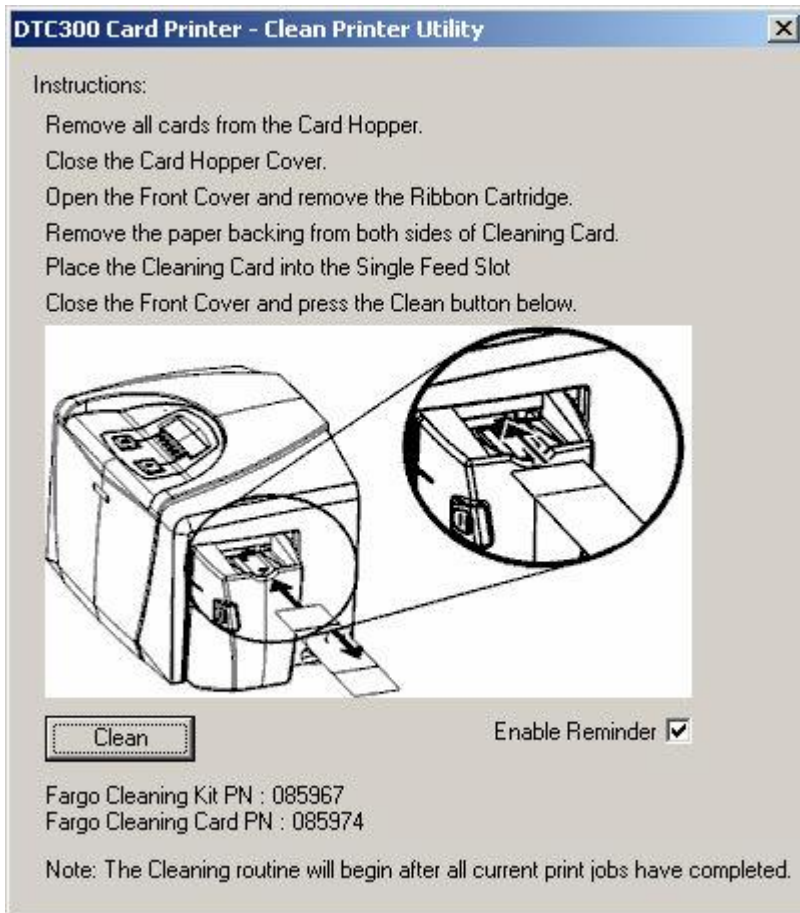

Using the Test Print button

Step	Description
1	<p>Click on the Test Print button to send a simple self-test print to the Printer.</p> <ul style="list-style-type: none"> • Ensure that a YMCKO Ribbon is installed for DTC300 or a Premium Resin Ribbon installed for DTC300M. • Ensure that the computer is effectively communicating with the Printer and that the Printer is functioning properly.

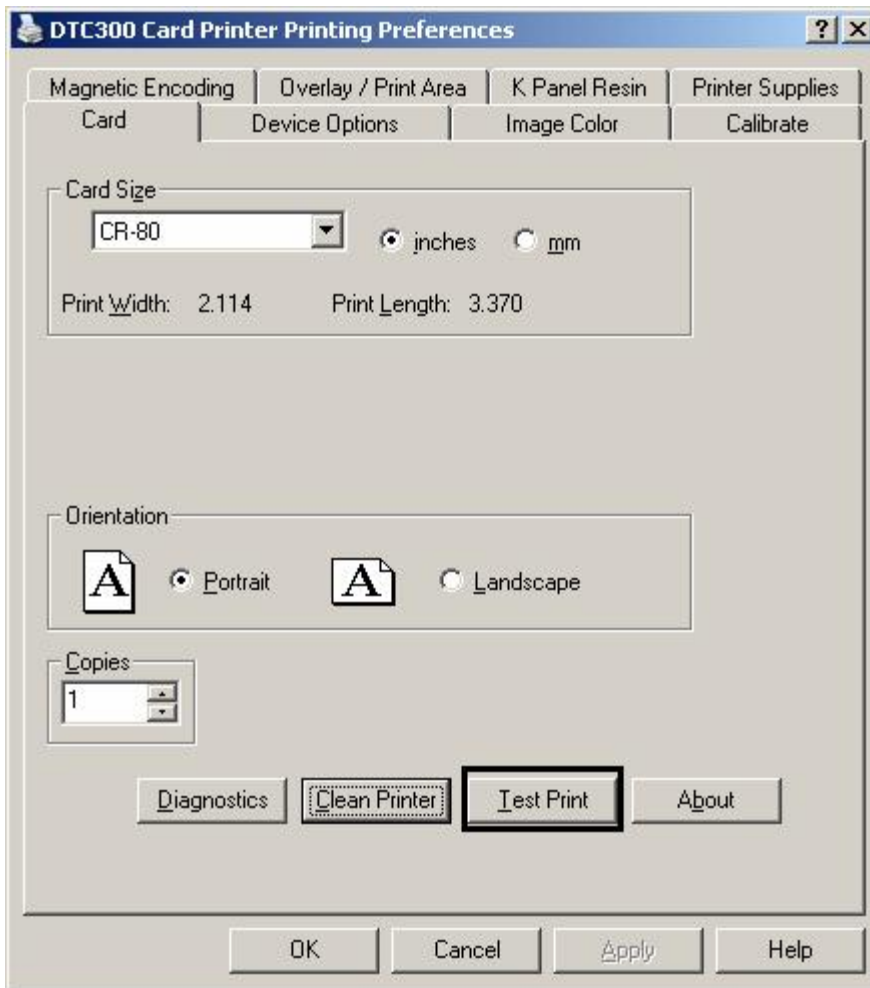

Using the About button

Step	Description
1	Click on the About button to open a dialog box containing the copyright and version, date code information about this Printer Driver software.

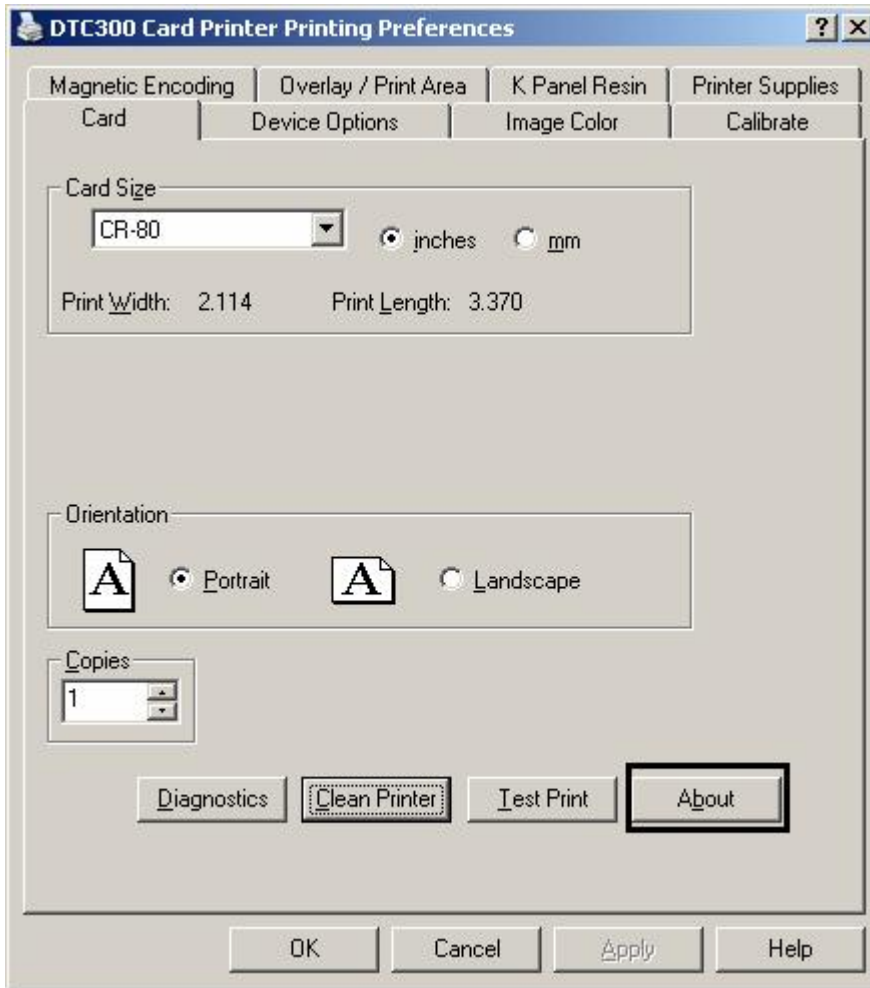

Using the Device Options tab (DTC300)

The DTC300/DTC300M window with the Device Options tab is displayed below.

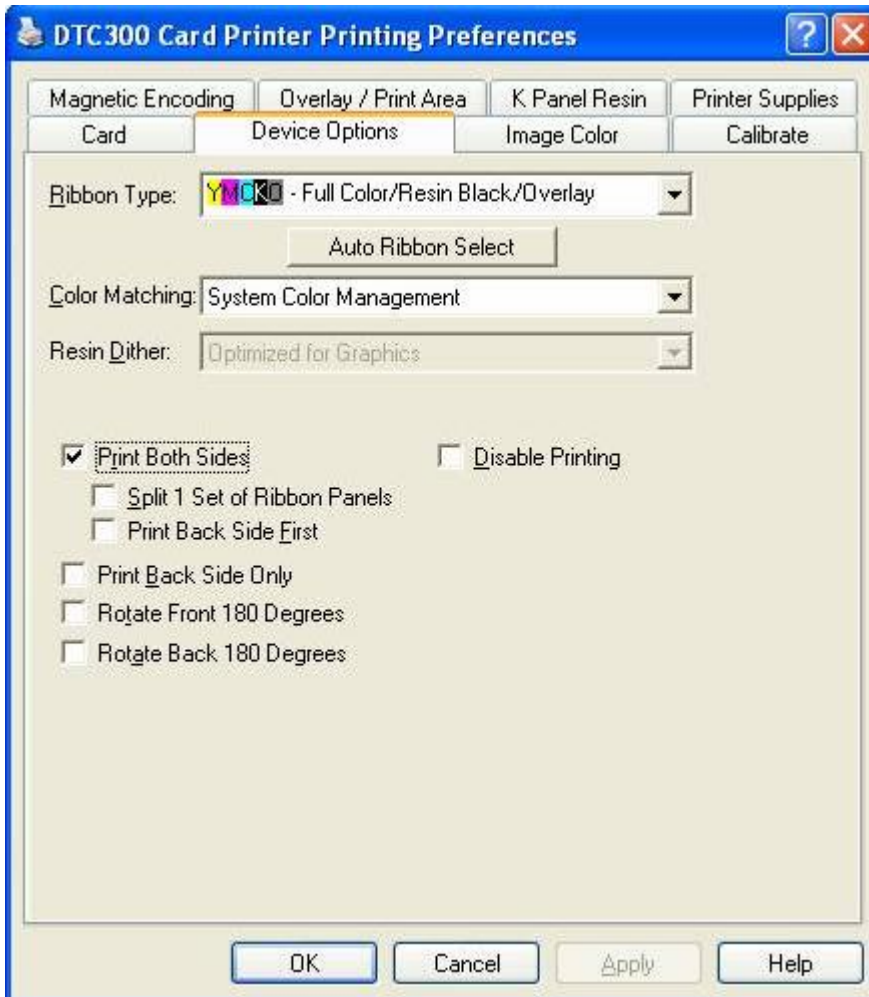

Adjusting the Ribbon Type option

Use the Ribbon Type option to select print Ribbons.

Step	Description
1	<p>Select the appropriate print Ribbon Type option from the dropdown menu for the type of print Ribbon in use.</p> <ul style="list-style-type: none"> • YMCKO – Full Color/Resin Black/Overlay • K – Standard Resin • K – Premium Resin • Colored Resin • Metallic Resin • KO – Premium Resin/Overlay

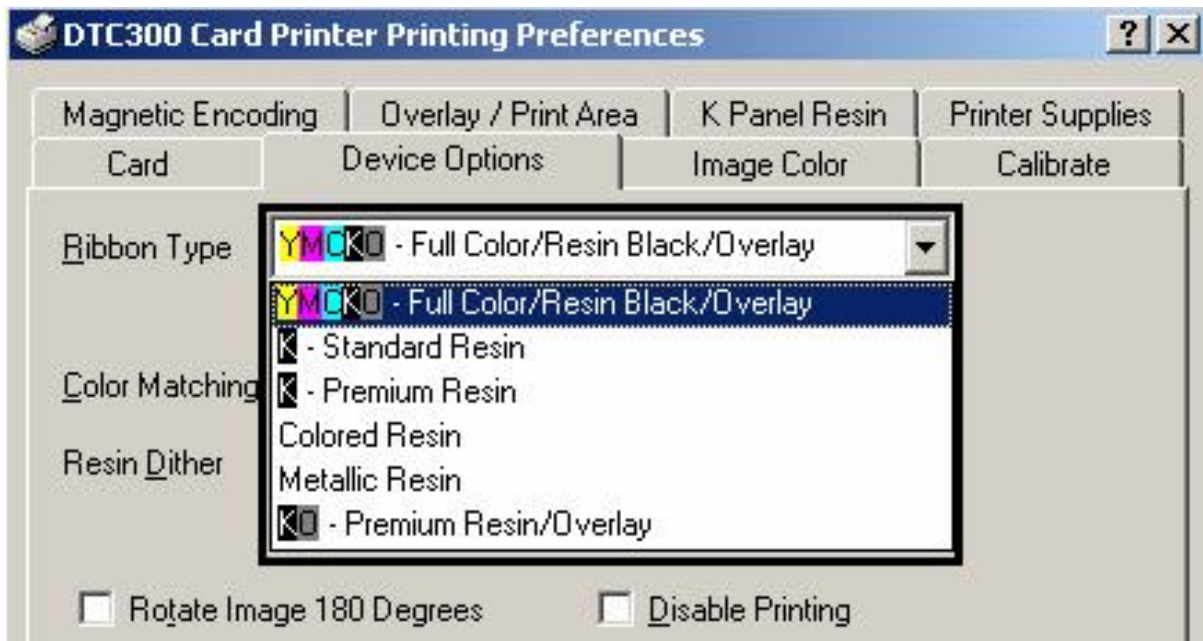

Selecting the Auto Ribbon Select option

Step	Description
1	Click on the Auto Ribbon Select button to verify that the Ribbon type selected matches the Ribbon installed in the Printer. (Note: The Printer Driver will change the Ribbon type to the correct setting or validate. It will also display a dialog that it has changed the current setting or that the current Ribbon type is correct.)

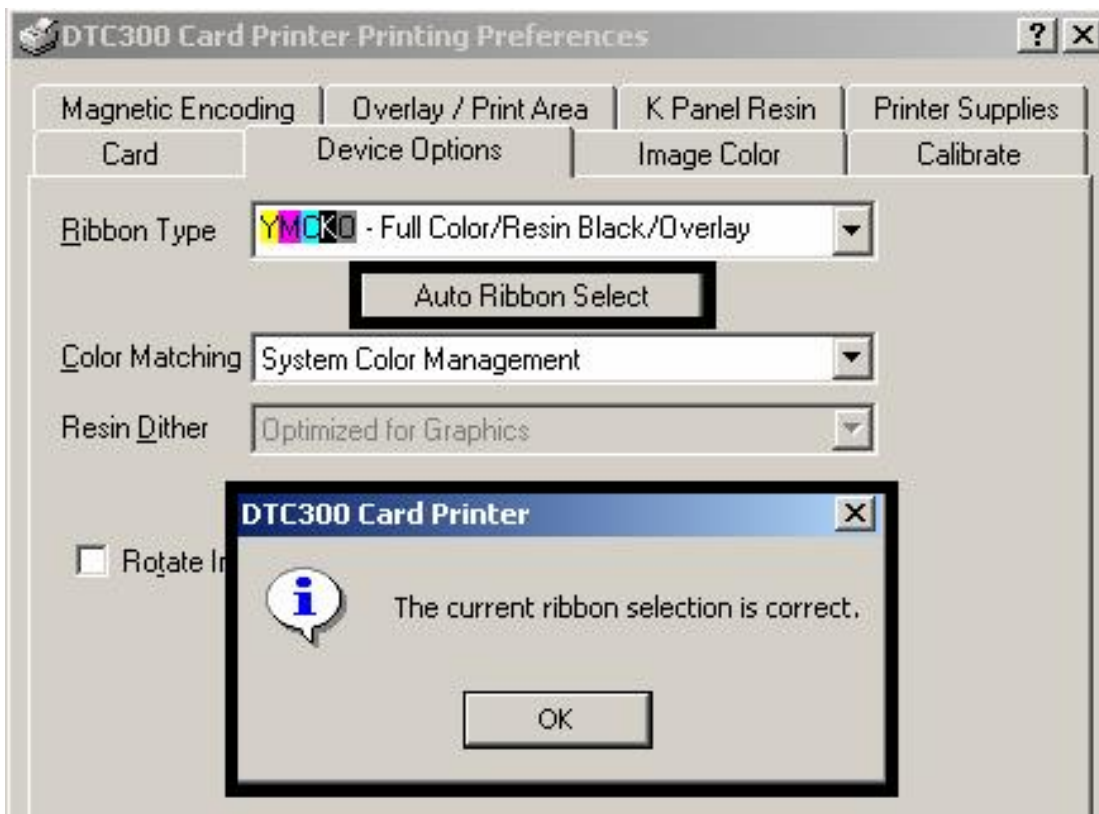

Using the new Printer Driver (Rev. 2.1.5)

Specific changes were made to the “new” Color Matching Table in the new Printer Drivers (Version 2.1.5) in the DTC300 Card Printer, as described below.

- **Precise Matching Capabilities:** These changes will affect how precisely the printed card matches the designed image on the computer screen.
- **Existing Color Table Capabilities:** These changes will produce more “true” blues and greens. (**Note:** We have a large customer base that uses the old color table. Consequently, the new Printer Driver has the option to install and use the existing Color Matching Table to prevent “impacting” current card designs.)
- **Driver Update Instructions:** The latest Printer Driver (Version 2.1.5) is needed for these specific color problems.

You can verify this setup in the DTC300 Card Printer Properties windows, as shown in the instructions provided in this Technical Update.

Changing the Color Profile Selection for the DTC300

Step	Procedure
1	a. From your computer’s startup menu, select Settings > Printers and Faxes (Windows XP) or Settings > Printers (Windows 98SE, Me and 2000). b. Double click on the DTC300 Card Printer under the Printers window. c. Select Properties under the Printer drop-down menu. (Note: This will bring up the DTC300 Card Printer Properties window, as shown on the next page.)
2	Click the Color Management tab.
3	Click Manual .
4	Click DT3CLR_E for improved color matching. (Note: This color profile has better screen to printer matching.) OR Click DT3CLR_O if you already have an existing base of cards using this color profile, and you want to maintain the same color matching. (Note: If the DT3CLR_O color profile is not listed, it can be added by clicking Add and browsing to %ProgramFiles%\Fargo\Printer Driver Software\DTC300\InstallINT\ and selecting DT3CLR_O.icm.)

Changing the Color Profile Selection for the DTC300 (continued)

Step	Procedure
5	Click Set as Default .

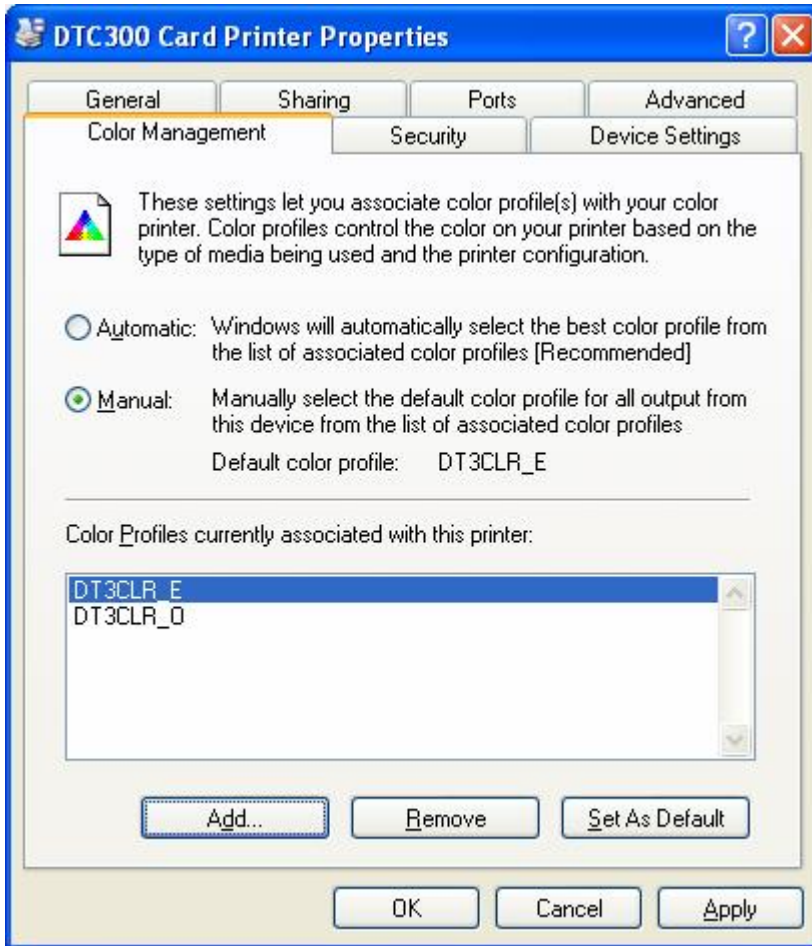

Adjusting the Color Matching option

Use the **Color Matching** dropdown menu to choose the color matching options which best fits the print job requirements.

Step	Description
1	<p>Select None for print speed versus print color or for use of third party color matching software.</p> <p>OR</p> <p>Select Algebraic (a) for the Printer Driver to make very simple, yet fast, color balance adjustments; (b) for more natural looking images without actually utilizing any specific color matching; or (c) for customized, printed coloring of the cards through the Image Color tab.</p> <p>OR</p> <p>Select Monitor for the Printer Driver to make color corrections similar to the Algebraic option but through a more complex color matching algorithm.</p> <p>OR</p> <p>Select System Color Management for Windows to make color corrections. This provides a closer match to the sRGB color specifications. (Note: This option shifts colors to a different color model so the colors in the image will more closely match how they appear on the monitor.)</p>

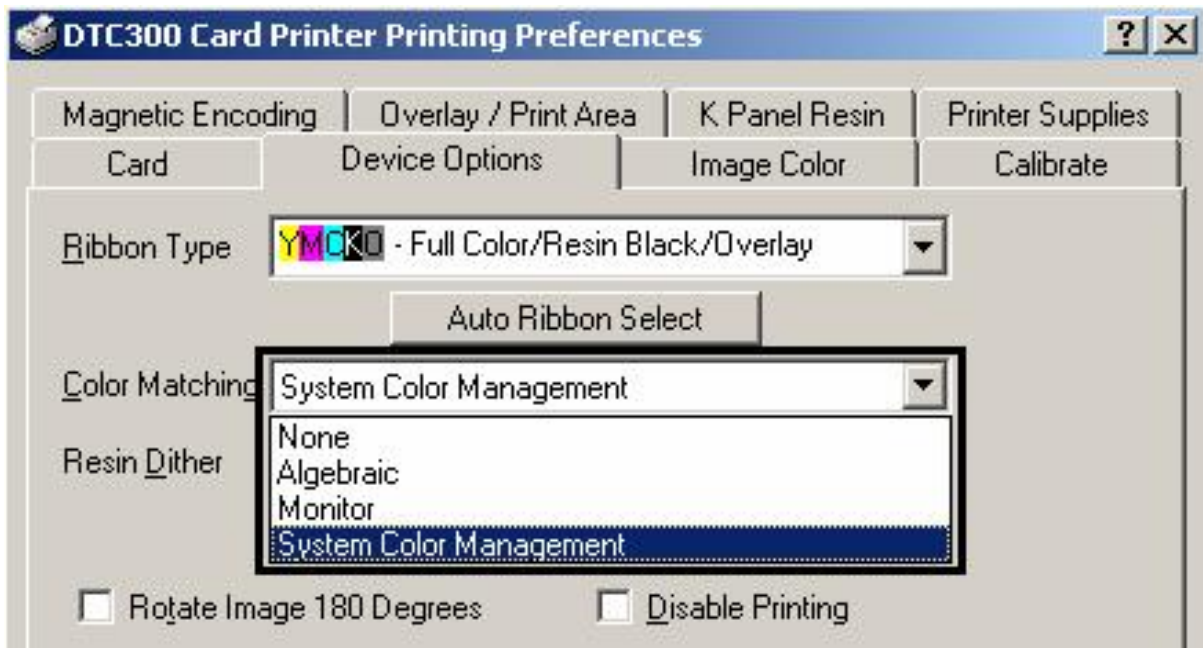

Adjusting for the Resin Dither

Select the appropriate dither method according to the type of image to be printed. This option affects objects printed with a resin-only print Ribbon.

Step	Procedure
1	Select Optimized for Photo when printing photo quality images with resin. OR Select Optimized for Graphics when printing drawings and graphics (e.g., clipart, logos, etc.) with resin.

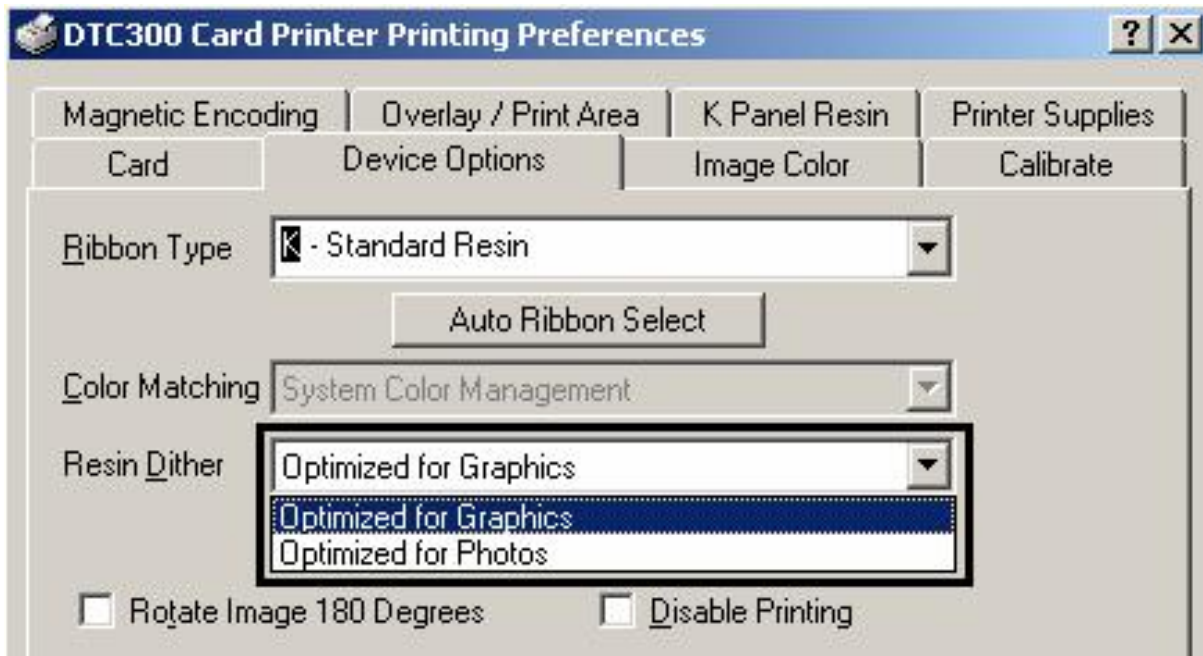

Using the Print Both Sides option

Use this option to automatically print on both the front and backside of a card.

Step	Procedure
1	Select this option in conjunction with any application program that supports a multiple-page document, duplex printing. (Note: The program must be able to send down two or more separate pages to be printed within the same document.)
2	<ul style="list-style-type: none"> • Page 1 will be transferred to the front side of the card. • Page 2 will be transferred to the backside of the card. <p>(Note: The Printer Driver will always place all odd numbered pages on the front side of the card and all even numbered pages on the back side with this option selected. If an odd number of pages are printed to the Driver while this option is selected, then the Printer will print an additional blank side, and transfer it to the card.)</p>

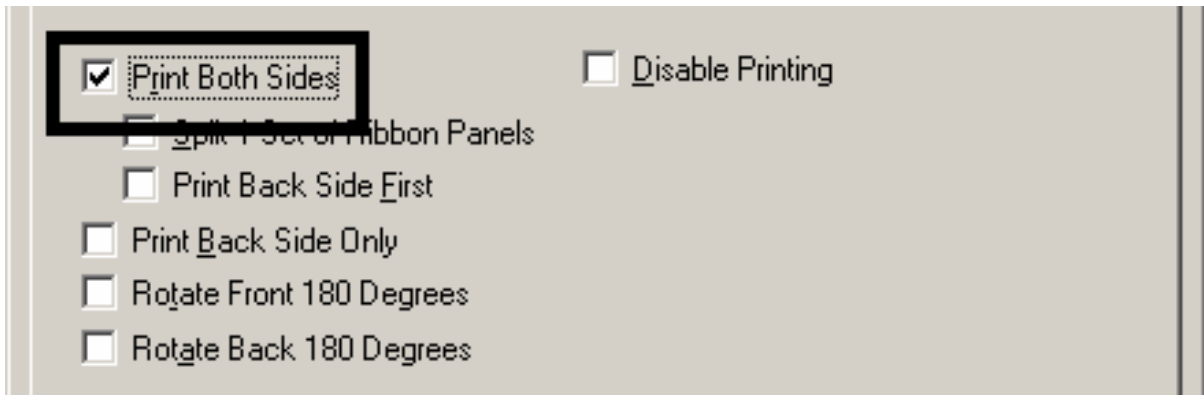

Using the Split 1 Set of Ribbon Panels option

Use this option to provide the most economical means of printing a dual-sided card since a single set of ribbon Panels will be split to print both the front and backsides of a card.

Step	Procedure
1	<p>Select this option to automatically print full-color on the front of a card and resin black on the back of a card (using either of the Full-color YMCK or YMCKK Print Ribbons).</p> <ul style="list-style-type: none"> • If using a YMCKO ribbon type, the front of the card is printed with the ribbon's YMC Panels and the back is printed with the K Panel, and the O Panel is printed on the front. • If using a YMCKOK ribbon type, the front of the card is printed with the YMCK Panels and the back is printed with the second K Panel. <p>(Note #1: This option is automatically enabled when the YMCKOK ribbon type is selected.)</p>



Using the Print Back Side First option

Step	Procedure
1	<p>Select this option:</p> <ul style="list-style-type: none">• If you need to print the first page of a two-page document on the backside of the card. <p>OR</p> <ul style="list-style-type: none">• If you need to print the resin black on the chip-side of the Smartcard. <p>The second page of the document will be printed on the front side of the card.</p>

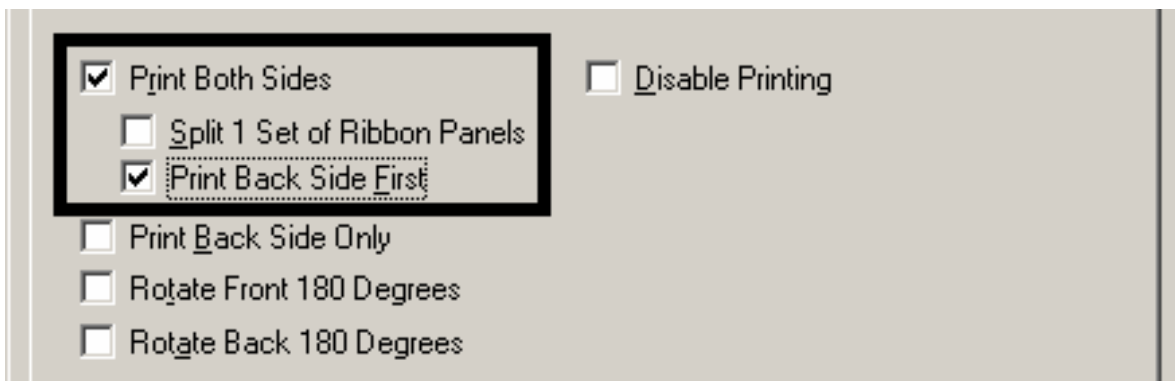

Using the Print Back Side Only option

Use this option to print only onto the backside of cards.

Step	Procedure
1	<p>Select this option to print only onto the backside of cards. (Note: Load the cards in the usual fashion.)</p> <ul style="list-style-type: none">• When this option is selected, the Print Both Sides option is automatically disabled.• When attempting to print a two-page document (if Print Back Side Only is selected), the first page of the document will print on the backside of the card.• The second page of the document will then be printed on the back of a second card.

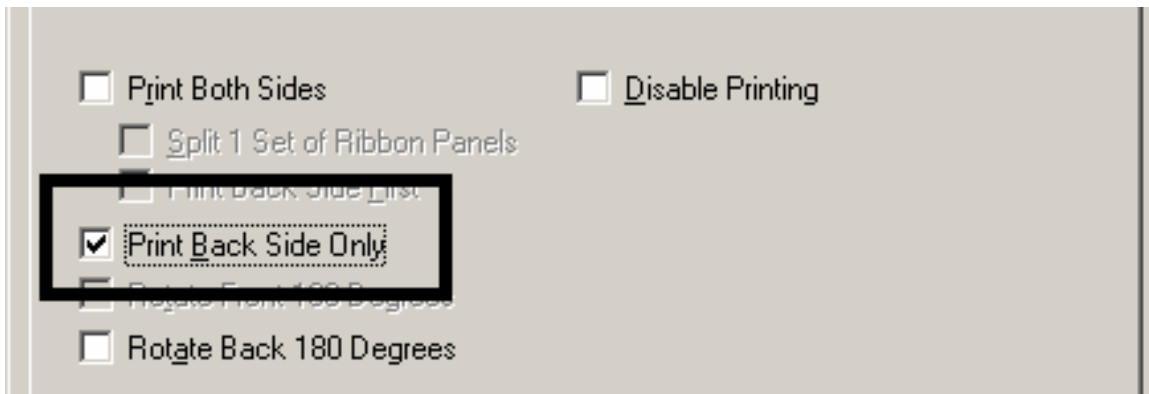

Using the Rotate Image 180 Degrees option

Use this option to rotate the image on the front of the card 180 degrees when printed.

Step	Description
1	Select this option to change the position of the printed image in relation to the set location of a card's Magnetic Stripe or smart chip.

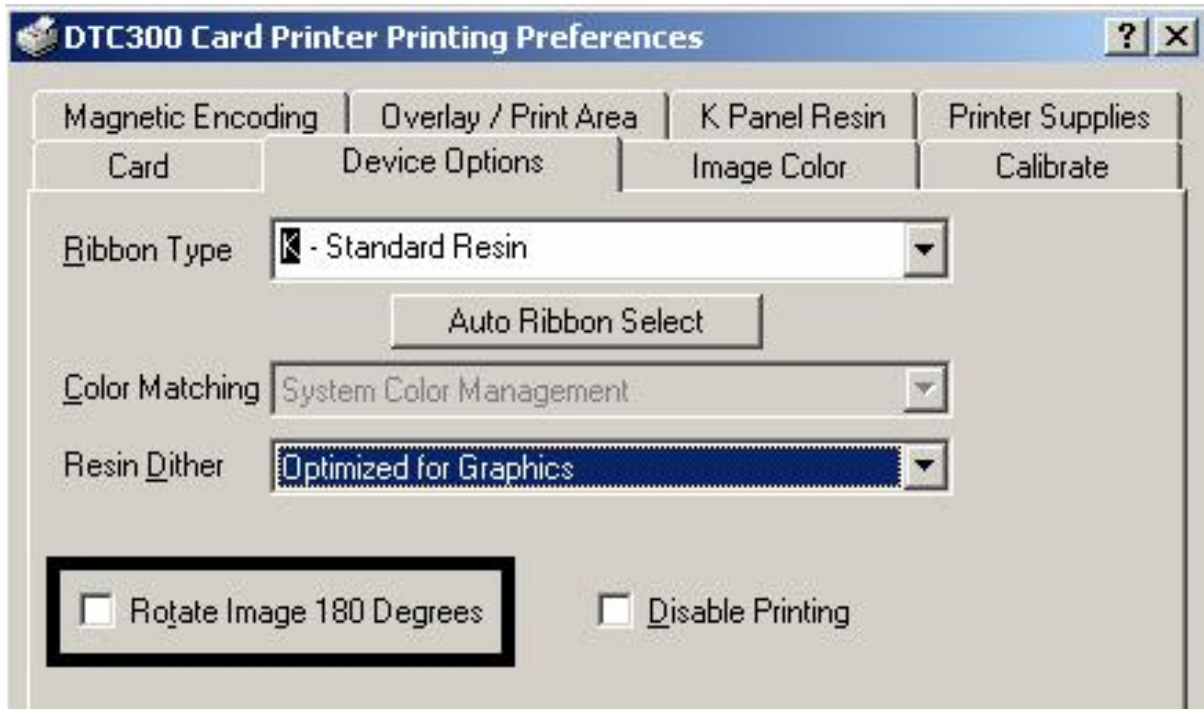

Using the Disable Printing option

Use this option to disable the printing capabilities of the Printer, yet still allows the Printer to encode cards.

Step	Description
1	Select this option to encode or re-encode cards without wasting additional time, effort, or printing supplies. (Note: When this option is selected, no print data will not be sent to the Printer. All encoding instructions will be sent according to how they are configured within the software.)

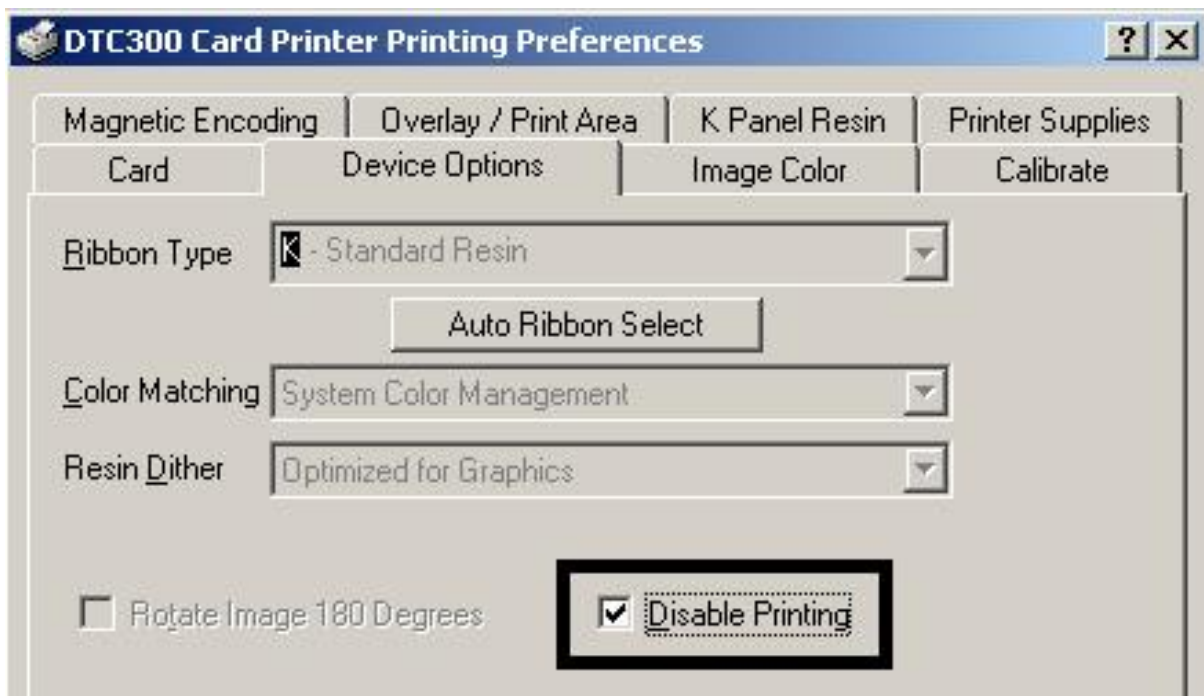

Using the Device Options tab (DTC300M)

Adjusting the Ribbon Type option

Use the Ribbon Type option to select print Ribbons.

Step	Description
1	<p>Select the appropriate print Ribbon Type option from the dropdown menu for the type of print Ribbon in use.</p> <ul style="list-style-type: none"> • K – Standard Resin • K – Premium Resin • Colored Resin • Metallic Resin • KO – Premium Resin/Overlay

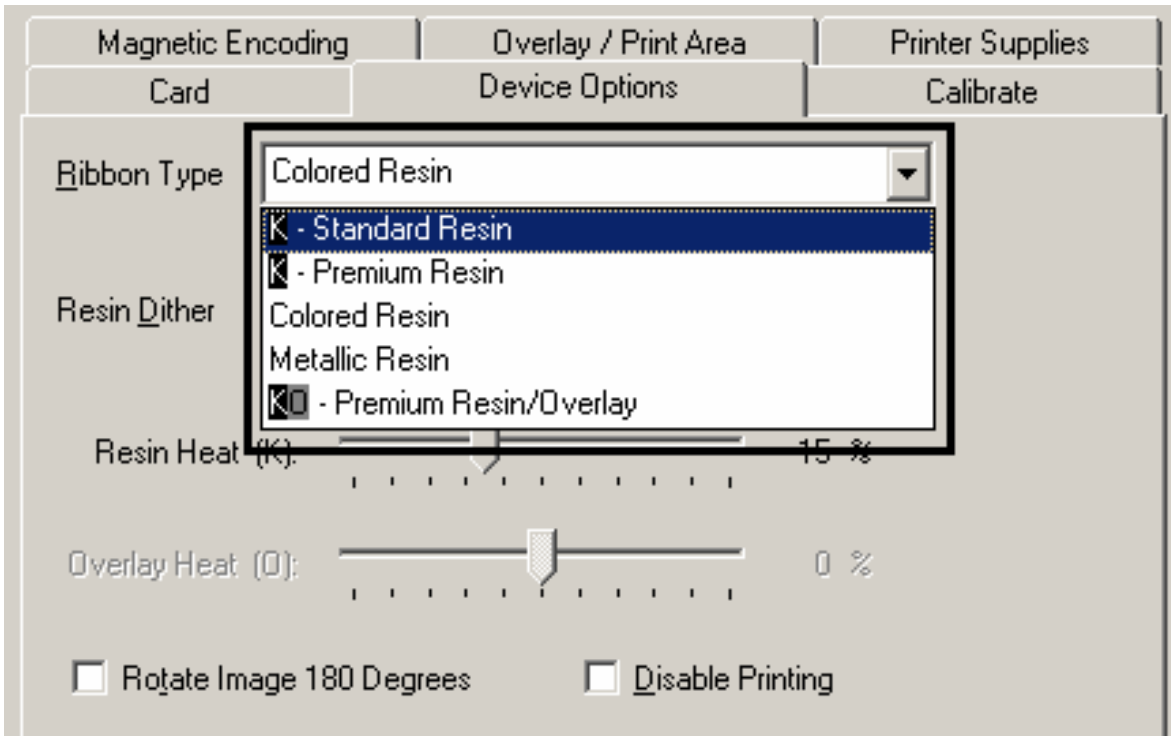

Selecting the Auto Ribbon Select option

Step	Description
1	Click on the Auto Ribbon Select button to verify that the Ribbon type selected matches the Ribbon installed in the Printer. (Note: The Printer Driver will change the Ribbon type to the correct setting or validate. It will also display a dialog that it has changed the current setting or that the current Ribbon type is correct.)

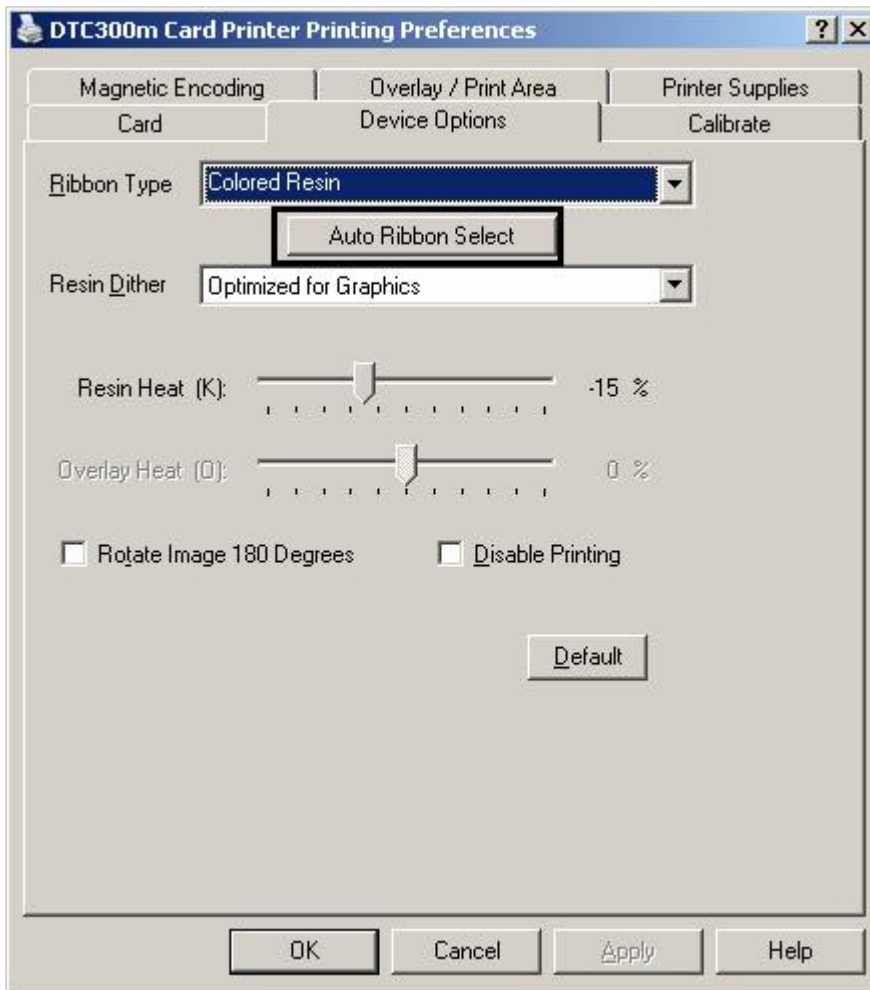

Adjusting for the Resin Dither

Select the appropriate dither method according to the type of image to be printed. This option affects objects printed with a resin-only print Ribbon.

Step	Procedure
1	Select Optimized for Photo when printing photo quality images with resin. OR Select Optimized for Graphics when printing drawings and graphics (e.g., clipart, logos, etc.) with resin.

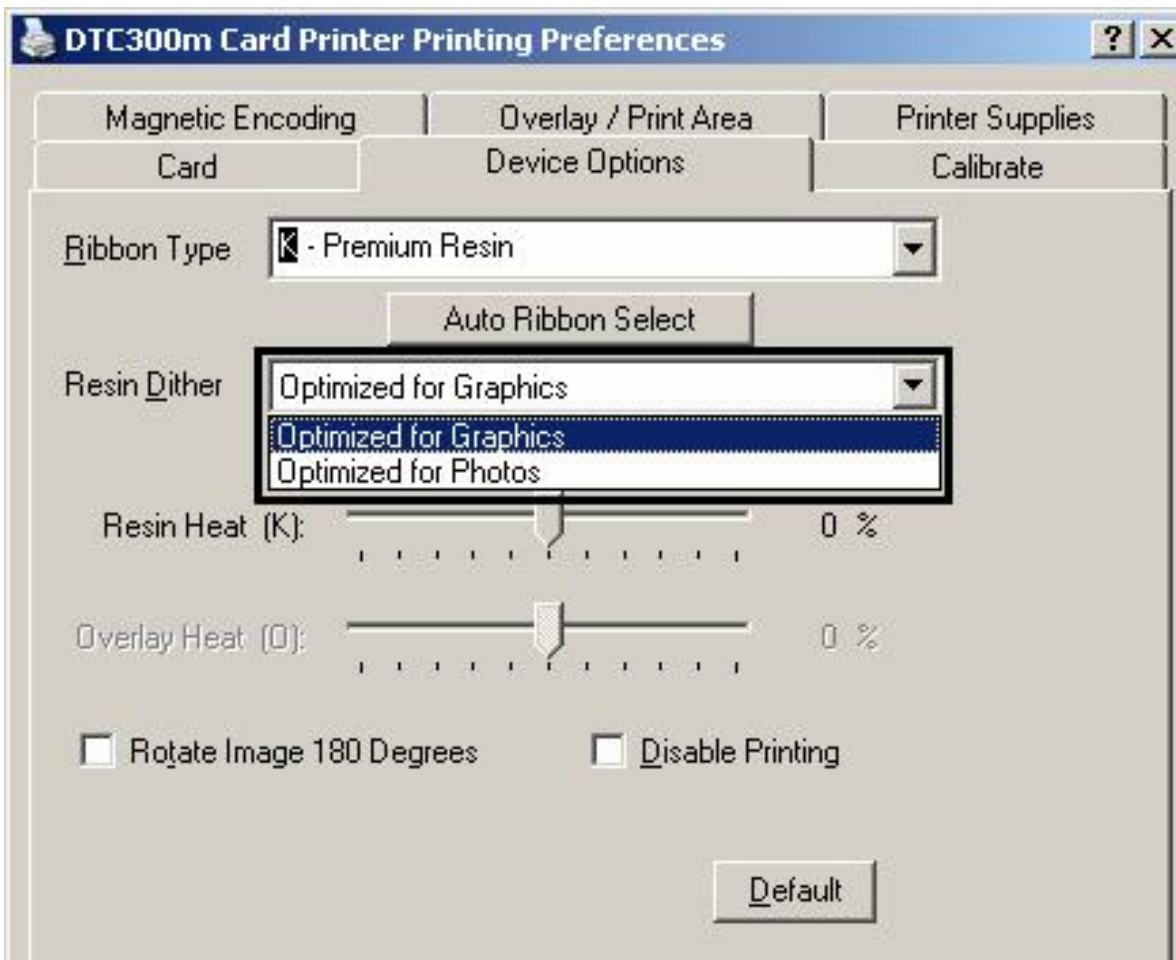

Using the Rotate Image 180 Degrees option

Use this option to rotate the image on the front of the card 180 degrees when printed.

Step	Description
1	Select this option to change the position of the printed image in relation to the set location of a card's Magnetic Stripe or smart chip.

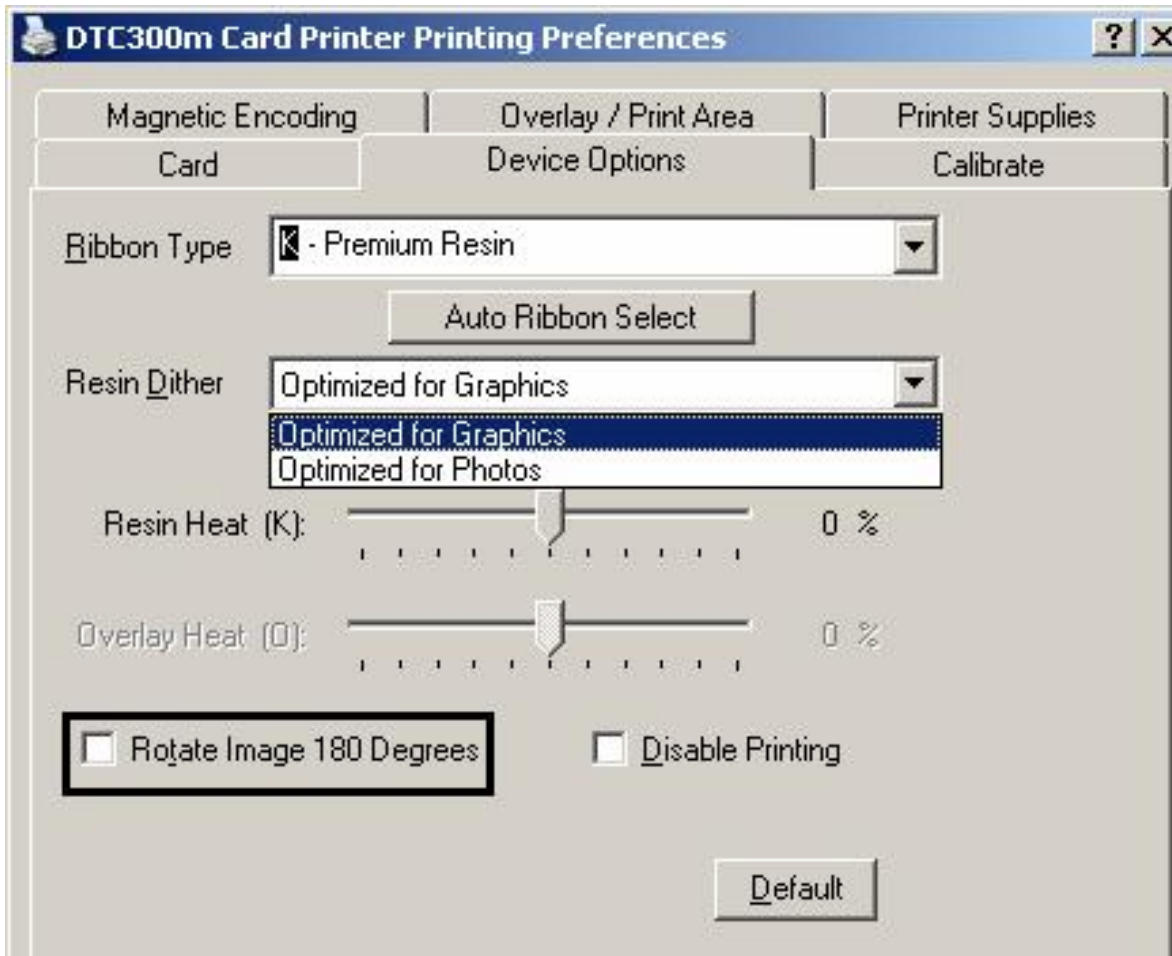

Using the Disable Printing option

Use this option to disable the printing capabilities of the Printer, yet still allows the Printer to encode cards.

Step	Description
1	Select this option to encode or re-encode cards without wasting additional time, effort, or printing supplies. (Note: When this option is selected, no print data will not be sent to the Printer. All encoding instructions will be sent according to how they are configured within the software.)

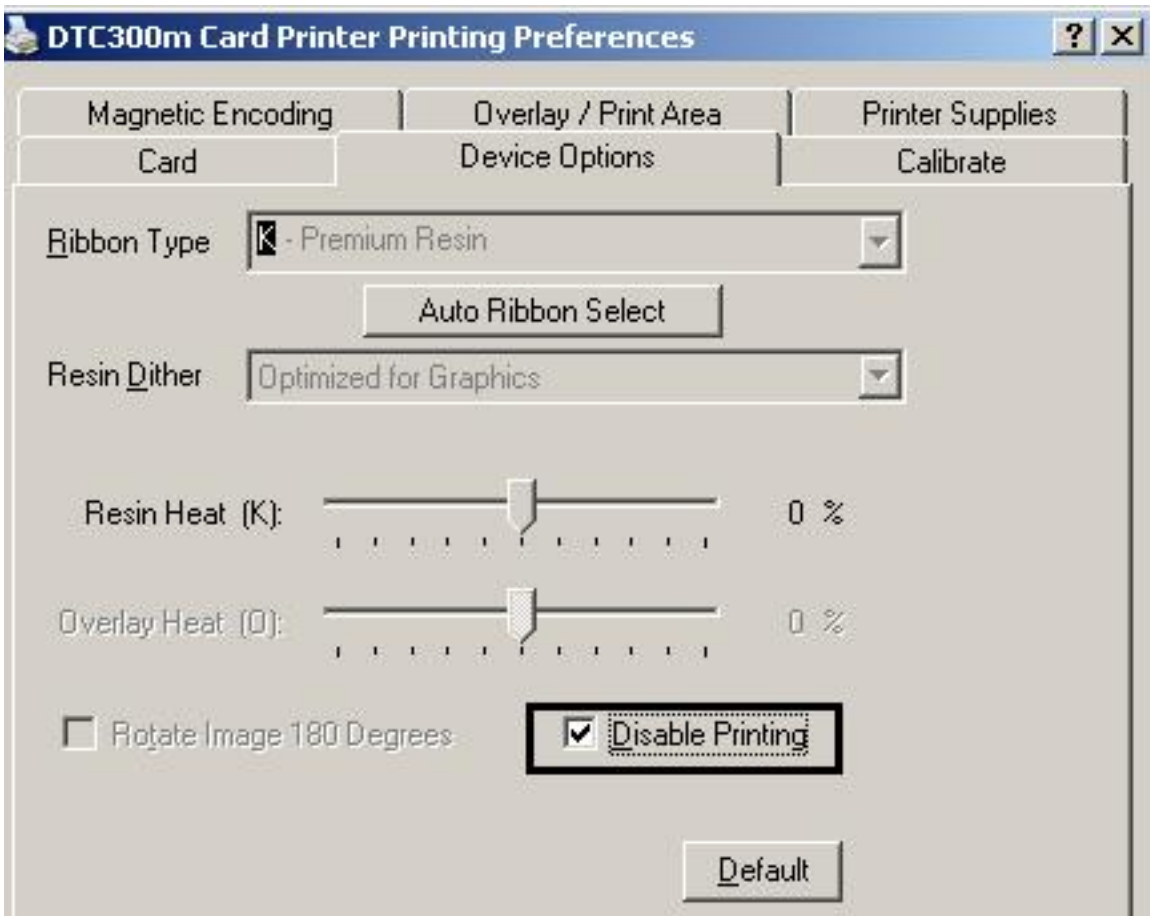

Using the Resin Heat (K) option

Use this option to control the amount of heat the Printer uses when printing with the resin black panel(s) of a full-color Ribbon or when printing with a resin-only Ribbon by adjusting the **Resin Heat** slide.

Step	Procedure
1	<p>Move the slide to the left to cause less heat to be used in the printing process, causing resin images to be lighter or less saturated.</p> <p>OR</p> <p>Move the slide to the right to cause more heat to be used.</p> <p>(Note: This control can be helpful for fine-tuning the transfer of resin text and bar codes.)</p>

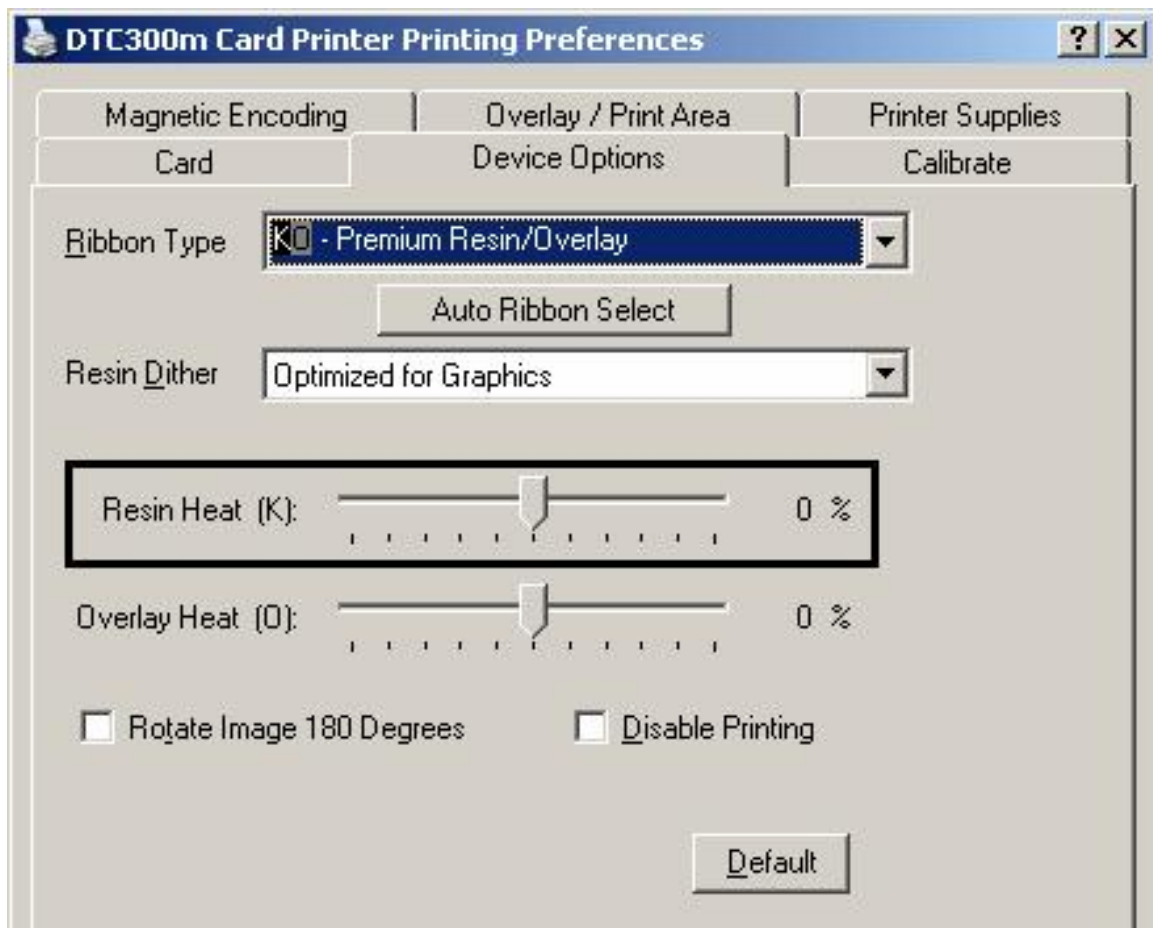

Using the Overlay Heat (O) option

Use this option to control the amount of heat the Printer uses when printing with the overlay panel of a Ribbon.

Step	Procedure
1	<p>Move the slide to the left to cause less heat to be used in the printing process. (Note: Certain card types may need additional heat for better transfer of the overlay material.)</p> <p>OR</p> <p>Move the slide to the right to cause more heat to be used.</p> <p>(Note: This control can be helpful for fine-tuning the transfer of overlay onto the card.)</p>

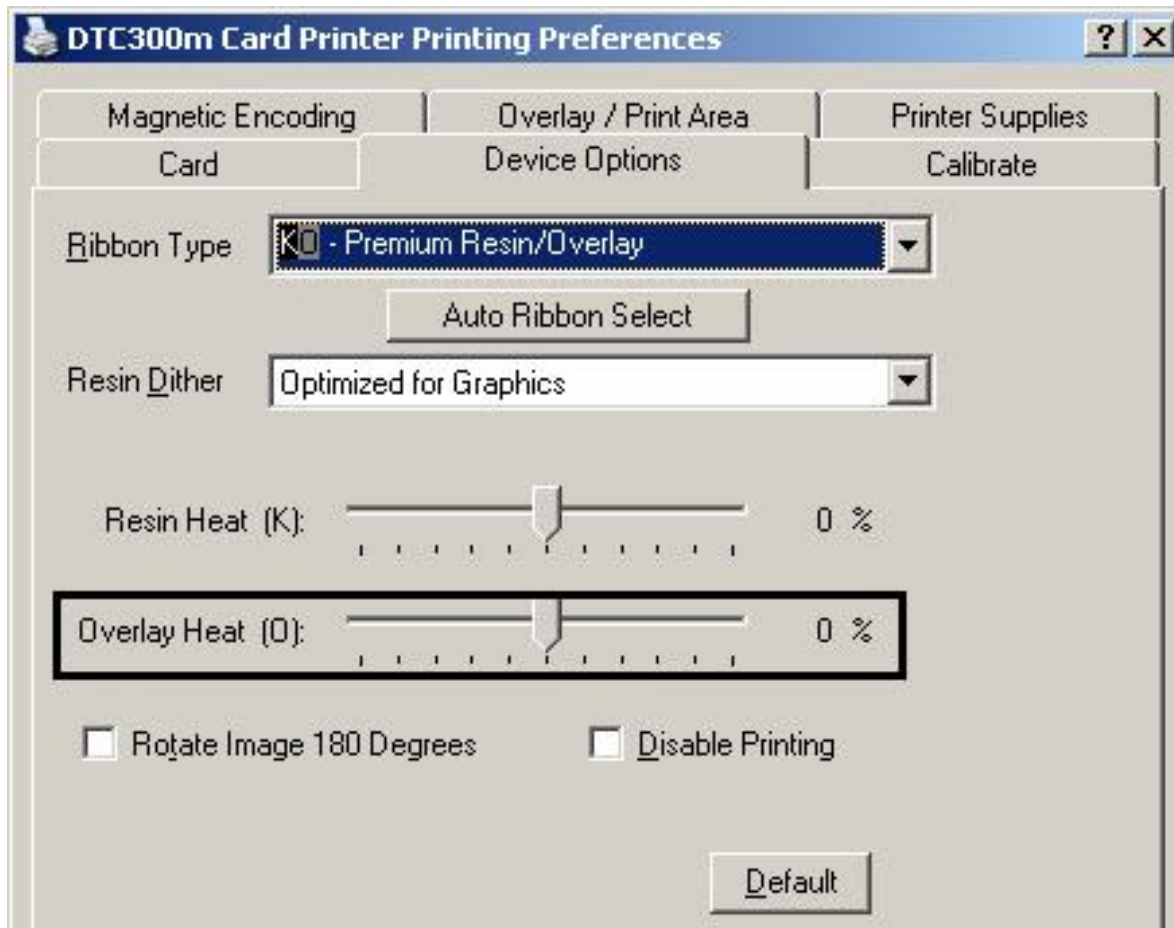

Using the Image Color tab (DTC300)

Step	Procedure
1	Select the Algebraic color matching option and then use this option to control the Contrast and Gamma of the printed image, as well as the individual color balance of Yellow , Magenta and Cyan . (Note: In most cases, the default settings of these options will suffice.)
2	Control the overall darkness and lightness of the printed image by adjusting the Dye-Sub Intensity slide by clicking and dragging the slide. <ul style="list-style-type: none"> • Move the slide to the left to cause less heat to be used in the printing process, thus generating a lighter print. <p>OR</p> <ul style="list-style-type: none"> • Move the slide to the right to cause more heat to be used, thus generating a darker print. (Note: This slide only affects those images printed with dye-sublimation Ribbon panels (YMC).)

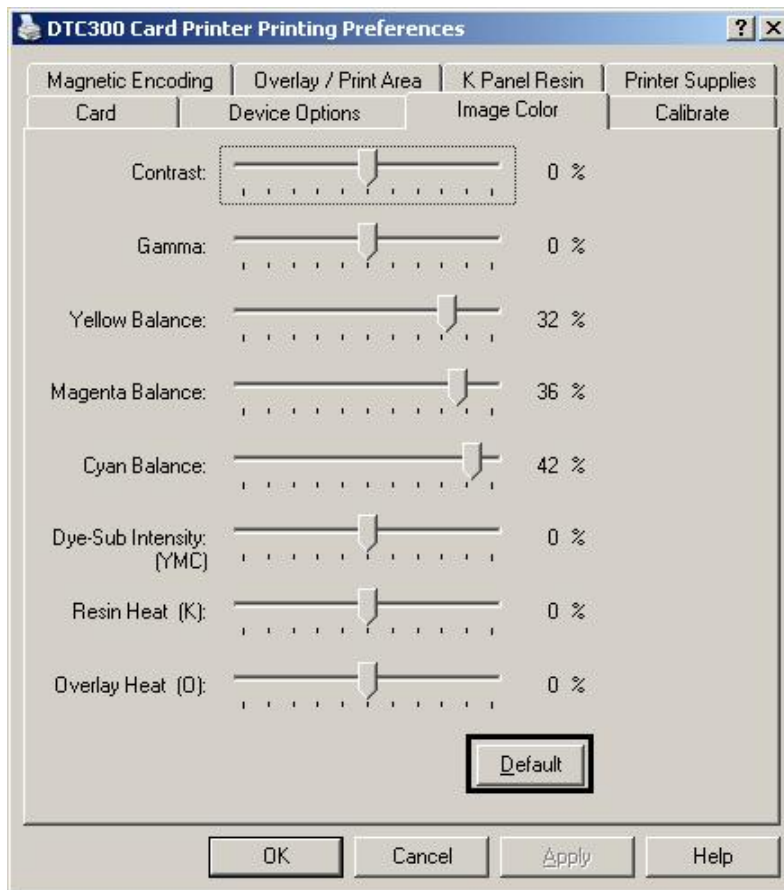

Using the Resin Heat (K) option

Use this option to control the amount of heat the Printer uses when printing with the resin black panel(s) of a full-color Ribbon or when printing with a resin-only Ribbon by adjusting the **Resin Heat** slide.

Step	Procedure
1	<p>Move the slide to the left to cause less heat to be used in the printing process, causing resin images to be lighter or less saturated.</p> <p>OR</p> <p>Move the slide to the right to (a) cause more heat to be used or (b) cause the resin image to be darker or more saturated.</p> <p>(Note: This control can be helpful for fine-tuning the transfer of resin text and bar codes.)</p>

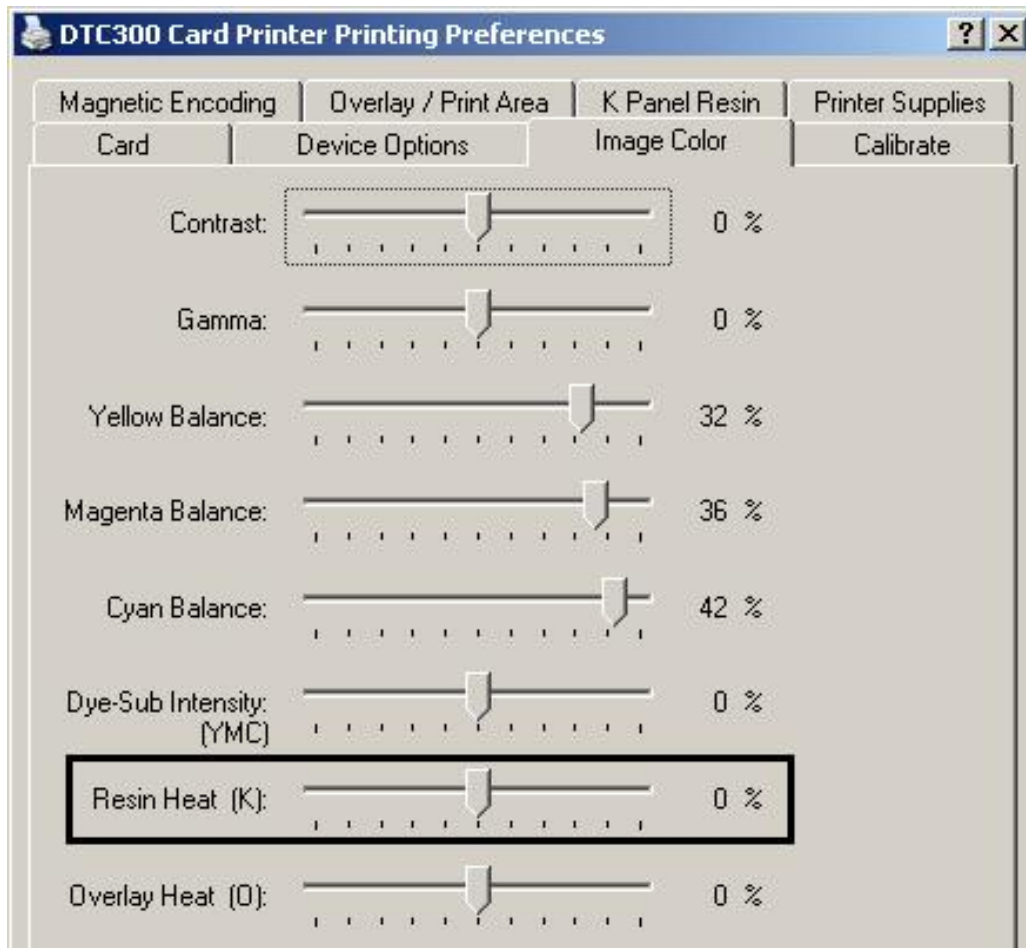

Using the Overlay Heat (O) option

Use this option to control the amount of heat the Printer uses when printing with the overlay panel of a Ribbon.

Step	Procedure
1	<p>Move the slide to the left to cause less heat to be used in the printing process. (Note: Certain card types may need additional heat for better transfer of the overlay material.)</p> <p>OR</p> <p>Move the slide to the right to cause more heat to be used.</p> <p>(Note: This control can be helpful for fine-tuning the transfer of overlay onto the card.)</p>

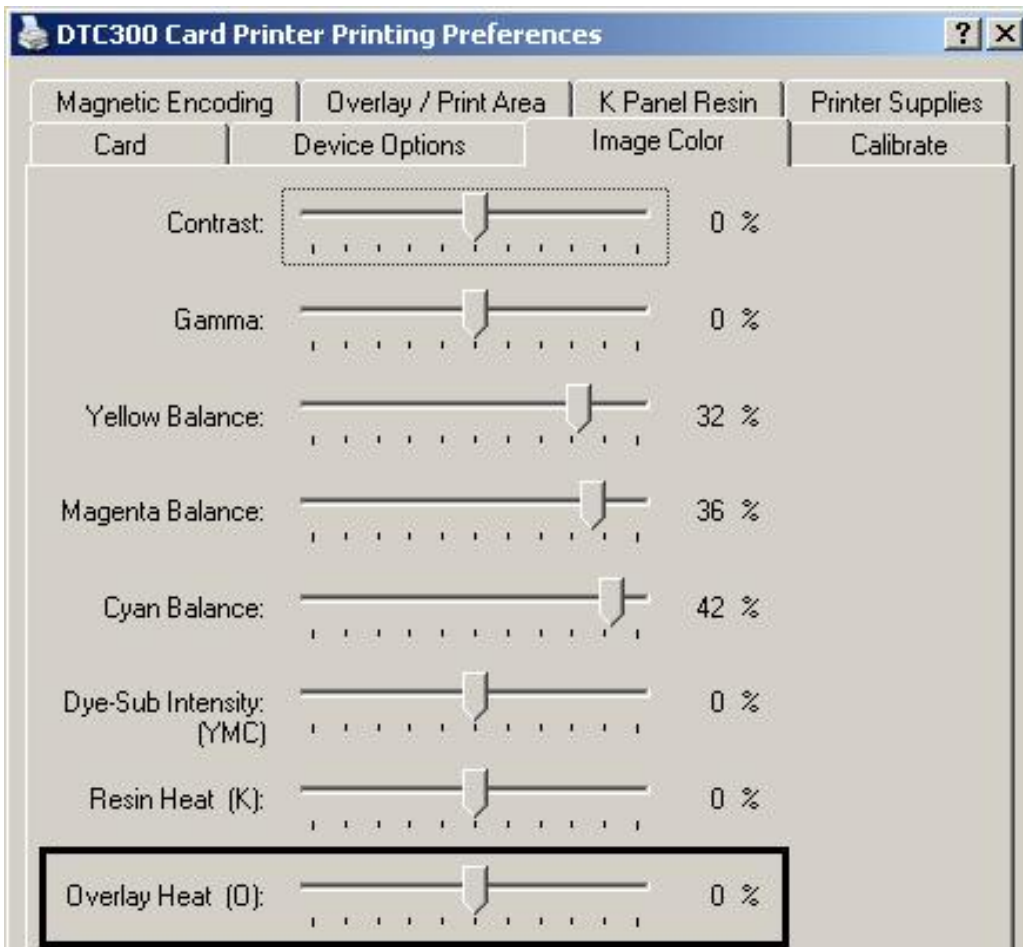

Using the Color Matching option and Default button

Step	Procedure
1	To return all options to their factory settings, click on the Default button.

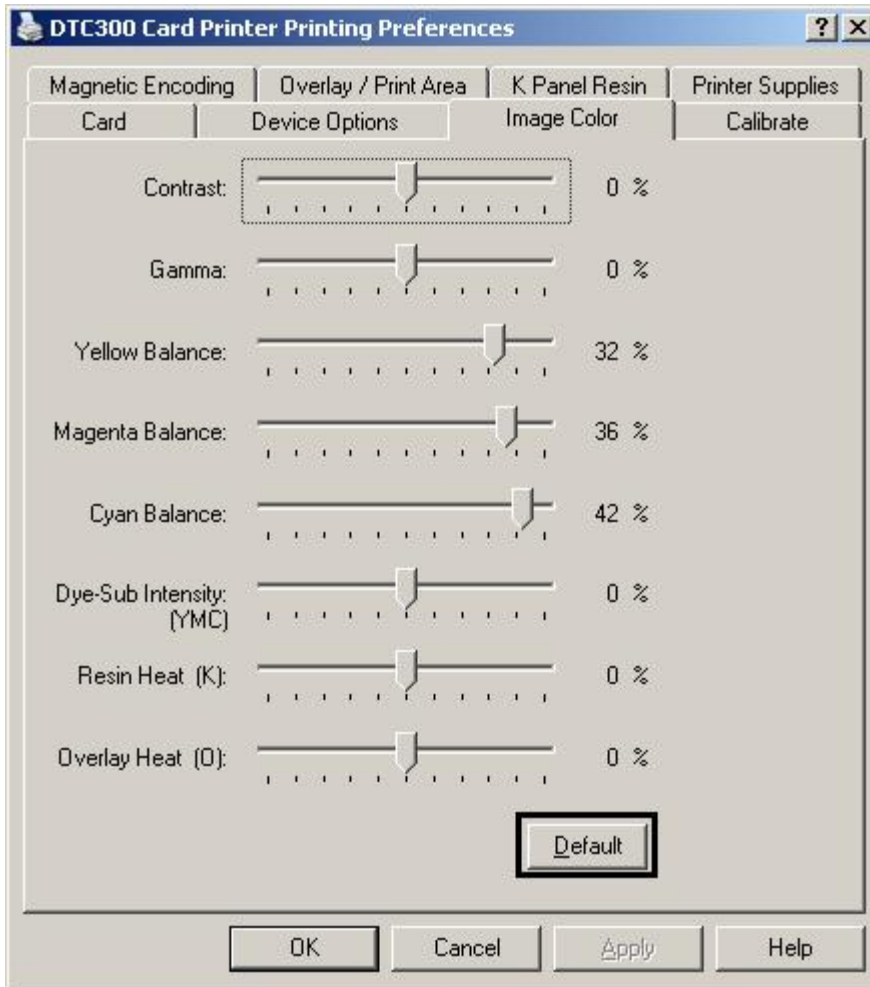

Using the Calibrate tab

Use the Calibrate tab to (a) control the position of the printable area in relation to the card, (b) calibrate Sensors and (c) adjust the internal Printer settings that are customized for every Printer and saved directly within the Printer's memory.

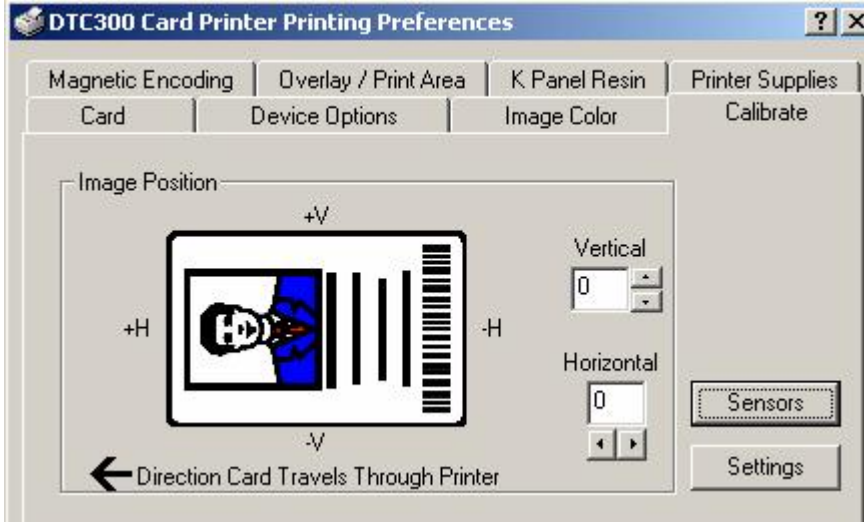

Using the Image Position Controls

Use the **Image Position** controls to adjust the position of the overall print area to be precisely centered on a card.

Step	Procedure
1	<p>Click on the Vertical and Horizontal adjustment arrows to adjust the Image Position values.</p> <ul style="list-style-type: none"> When adjusting these values, keep in mind that cards always remain in the same position while moving through the Printer, regardless of image orientation. To illustrate this, the card illustration shown in the Image Position box will flip and rotate according to the Portrait, Landscape, or Rotate 180 Degrees selection. The outline around the illustration will always remain in the same Landscape orientation.

Continued on the next page

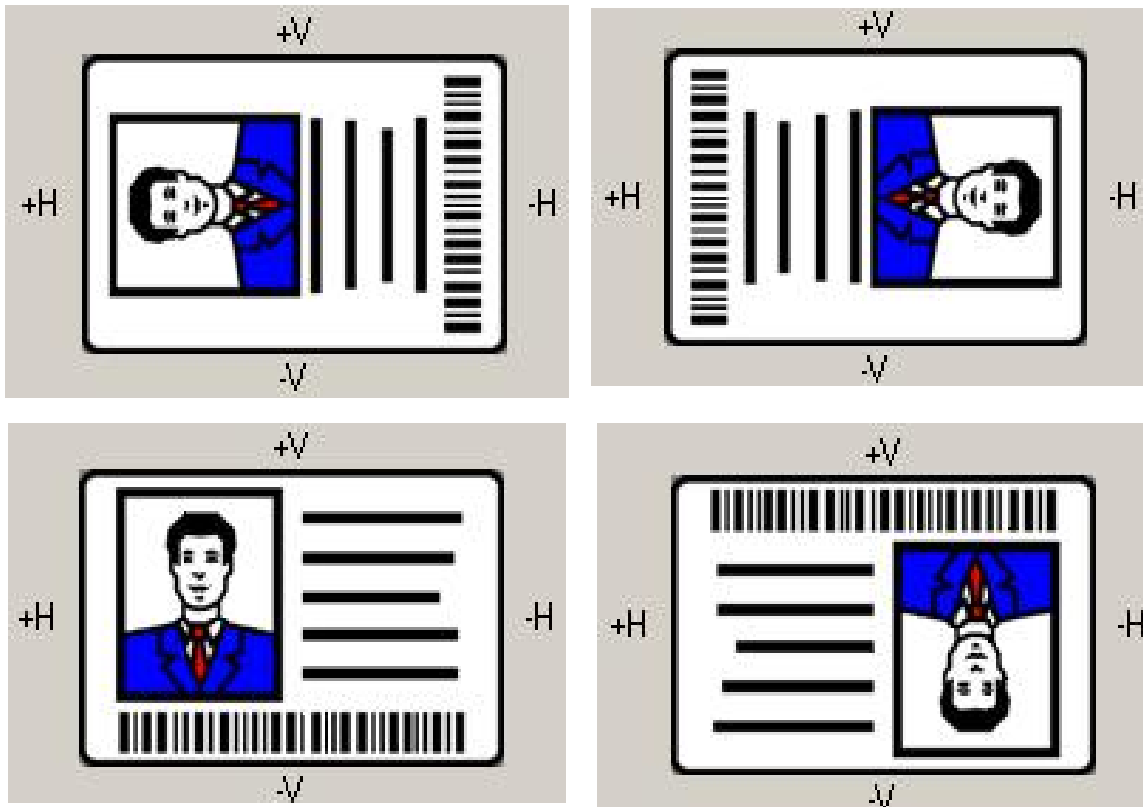

Using Image Position controls (continued)

Review the Image Position diagram, which displays how the printed image will move in relation to the fixed card position as positive and negative image placement values are entered.

Step	Procedure
2	<p>Use the Vertical adjustment to move the image:</p> <ul style="list-style-type: none"> • Move toward the rear of the Printer if a positive number is entered. • Move toward the front of the Printer if a negative number is entered. <p>OR</p> <p>Use the Horizontal adjustment to move the image:</p> <ul style="list-style-type: none"> • Move toward the card output side of the Printer if a positive number is entered. • Move toward the card input side of the Printer if a negative number is entered. <p>(Note No.1: The maximum value for the Vertical and Horizontal adjustments is ± 100 pixels (10 pixels = about .03"/. 8mm).)</p> <p>(Note No.2: The Vertical and Horizontal adjustment arrows point to within the Image Position window, which represents the direction that the printed image moves.)</p>

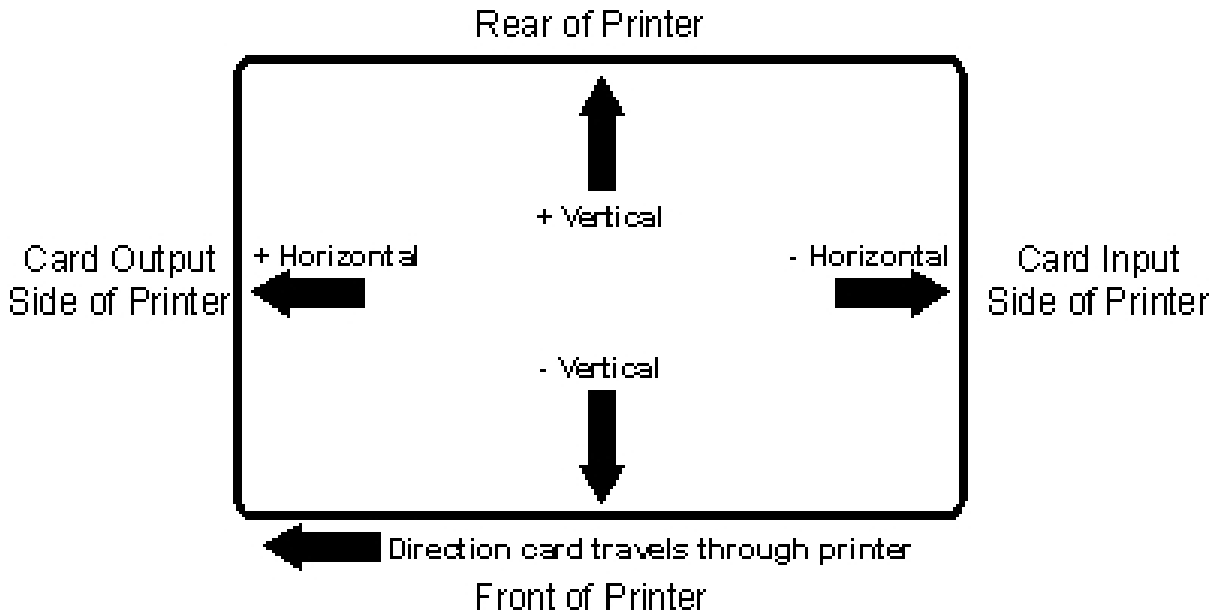

Using the Sensors button

Use the **Sensors** button to bring up a separate dialog box for calibrating the Printer's Ribbon Sensor (see instructions in the Calibration window below).

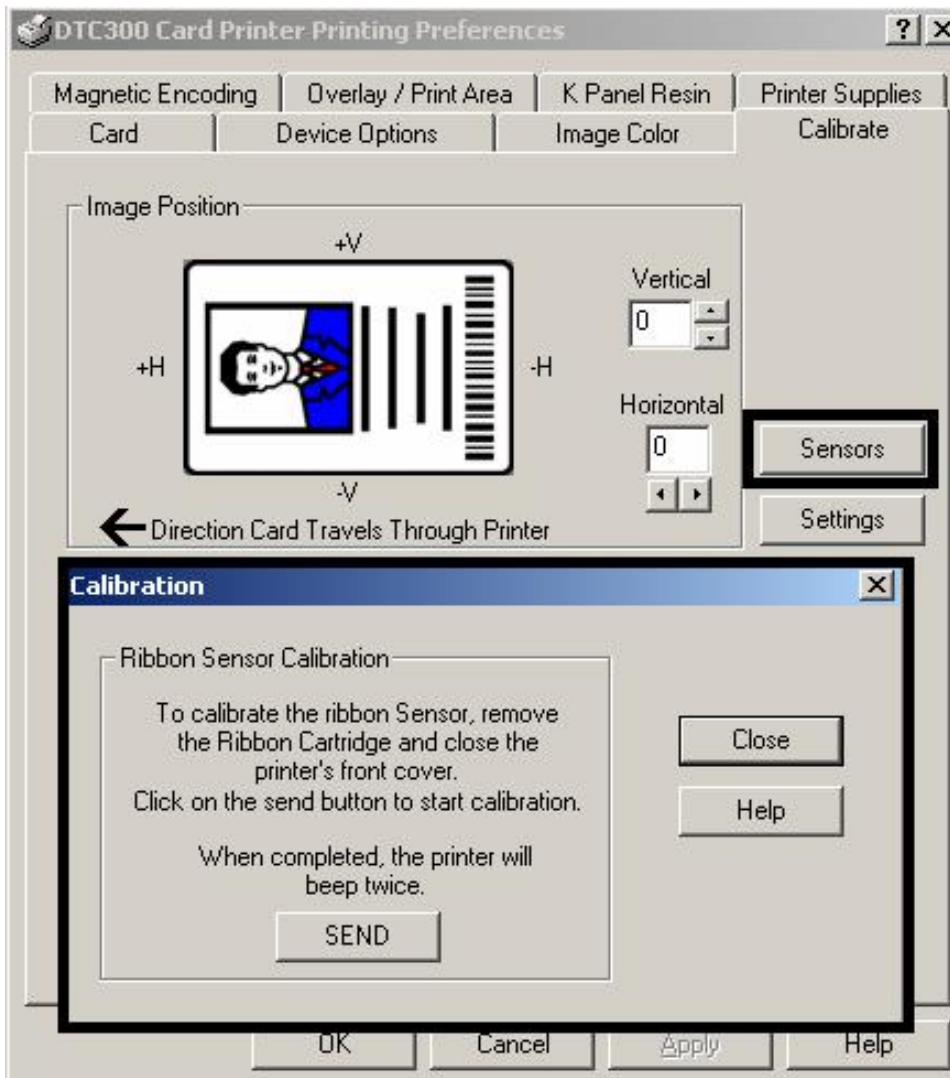

Using the Settings button

Use the **Settings** button (see above) to bring up a separate dialog box for adjusting the internal Printer settings, which are customized for every Printer at the factory and saved directly within the Printer's memory. (**Note:** You can select the Restore Defaults to restore the internal default settings.) See the [Using the Settings dialog box](#) procedure.

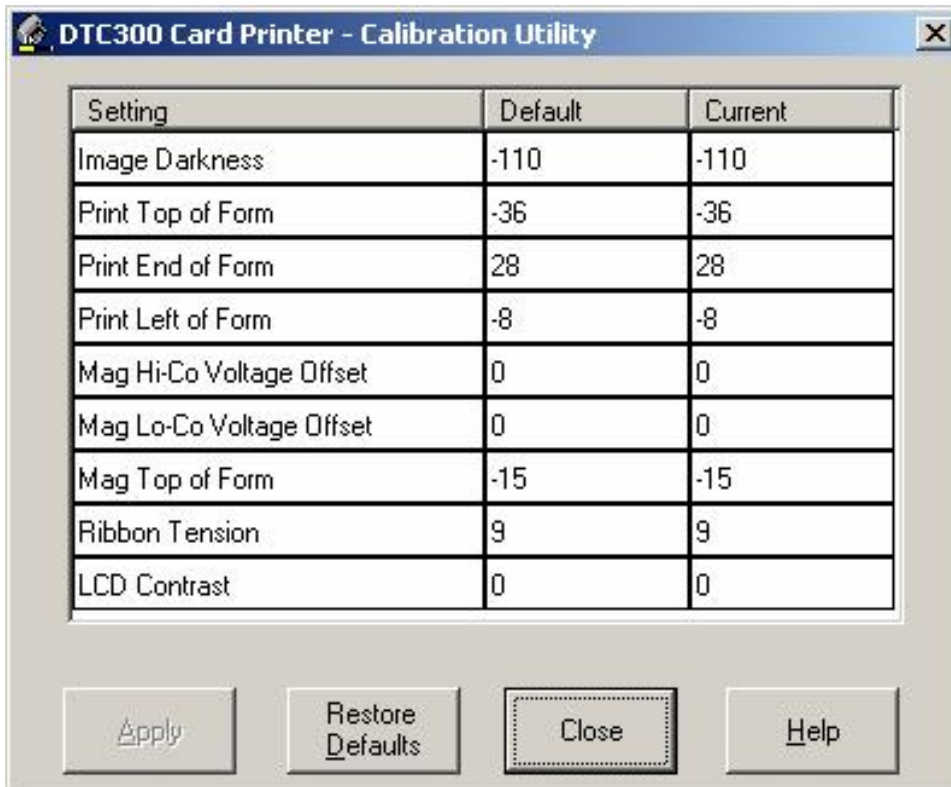

Using the Magnetic Encoding tab

Use this option only if the Printer has an optional Magnetic Stripe Encoding Module installed. The following describes these options and the Printer's magnetic encoding process.

- The Card Printer comes with either a high-coercivity factory-installed Magnetic Stripe Encoding Module or a low-coercivity module.
- The Printer cannot encode both types of Magnetic Stripes interchangeably within the same Printer.

Step	Procedure
1	Select the Magnetic Encoding tab to display options for controlling the Magnetic Stripe encoding process.

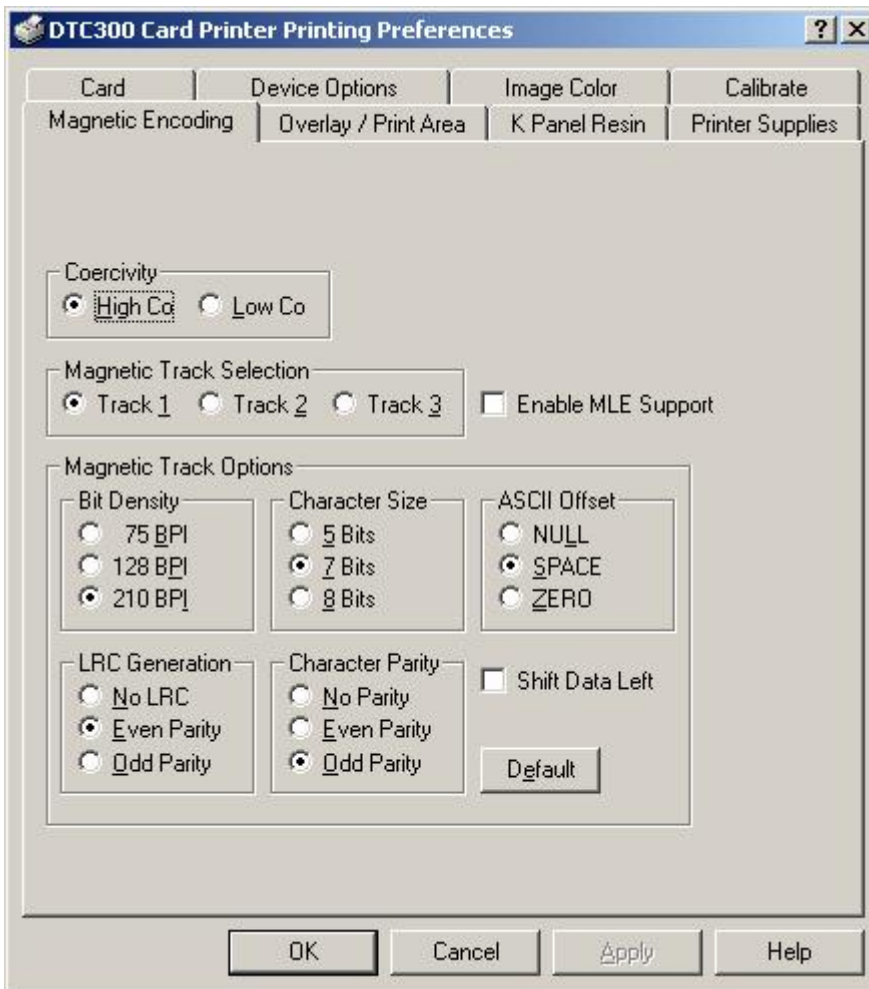

Using the Magnetic Track Selection radio buttons

Use the **Magnetic Track Selection** option to specify which track to configure through the Magnetic Track Options if the application requires customization of the standard ISO encoding process. (**Note:** Although the default ISO Magnetic Track Options should be correct for almost all applications, these options can be customized if the application requires it.)

Step	Procedure
1	Select a Track selection to: <ol style="list-style-type: none"> Change all options separately for each of the three individual tracks. Select the Default button for each of the separate tracks to set these options back to the ISO Standard settings (once they have been changed). (Important: Please refer to the following for a description of all Magnetic Track Options.)

Continued on the next page

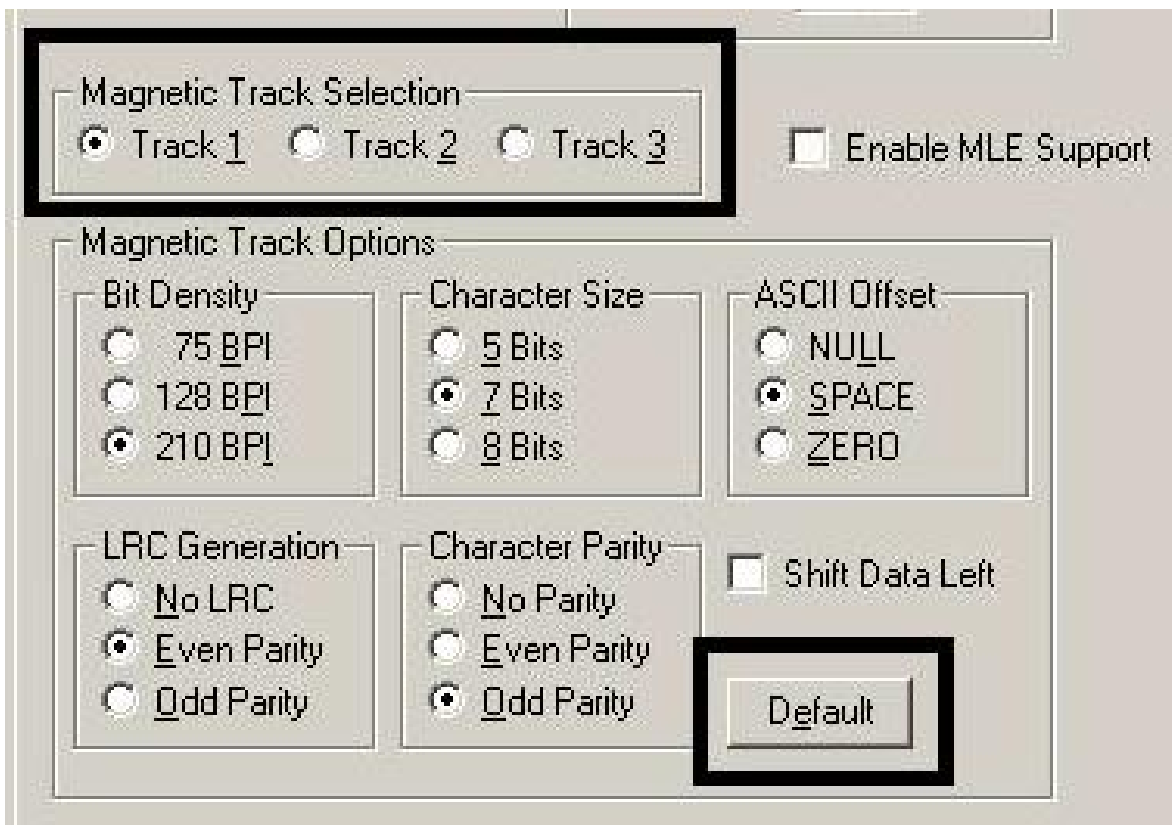

Using the Magnetic Track Selection radio buttons (continued)

Step	Procedure
2	<p>Use the Magnetic Track Selections to configure the way in which each of the three magnetic tracks will encode.</p> <p>(Note No.1: They do not designate which tracks the Printer will encode (e.g., to encode only Track 2). This must be done through the specific software program.)</p> <p>(Note No.2: Although the Printer Driver will remember the settings specified for each of the three tracks, the Printer Driver will always default to displaying the options for Track 1 whenever the Printer Driver setup screen is first opened.)</p>

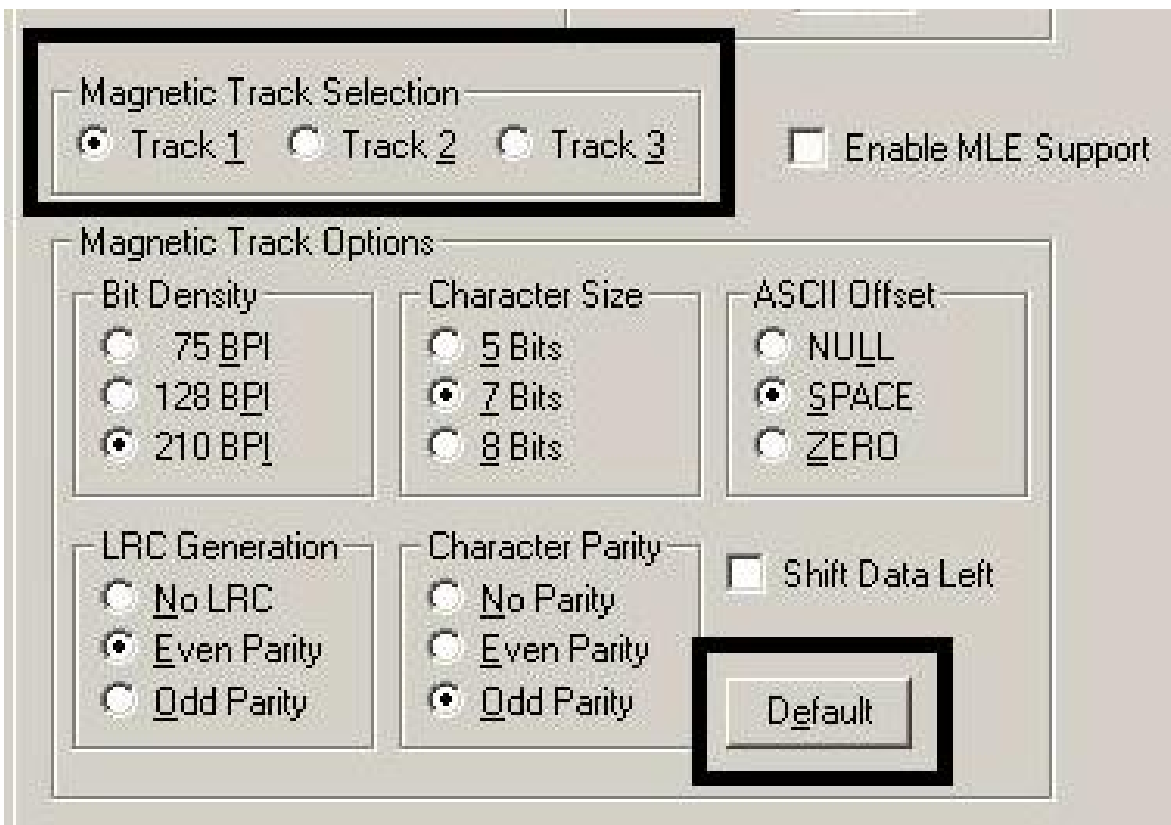

Using the Magnetic Track Options radio buttons

Use the **Magnetic Track** options for these purposes:

- Customize the ISO encoded data format for each of the Magnetic Stripe's three tracks.
- Customize each track independently of the other two.
- Specify which of the three tracks to customize by selecting one of the three track options.

(**Note No.1:** After making the required selection, the Magnetic Track Options box displays the current set of customization options for the selected track.)

(**Note No.2:** For most applications, the default settings for these options do not need to be changed.)

Magnetic Track Options

Bit Density <input type="radio"/> 75 BPI <input type="radio"/> 128 BPI <input checked="" type="radio"/> 210 BPI	Character Size <input type="radio"/> 5 Bits <input checked="" type="radio"/> 7 Bits <input type="radio"/> 8 Bits	ASCII Offset <input type="radio"/> NULL <input checked="" type="radio"/> SPACE <input type="radio"/> ZERO
LRC Generation <input type="radio"/> No LRC <input checked="" type="radio"/> Even Parity <input type="radio"/> Odd Parity	Character Parity <input type="radio"/> No Parity <input type="radio"/> Even Parity <input checked="" type="radio"/> Odd Parity	<input type="checkbox"/> Shift Data Left Default

Using the Bit Density radio buttons

Use this option to customize the Bit Recording Density (Bits per Inch) used to encode the magnetic data on the currently selected track.

Step	Procedure
1	Select 75 BPI to change the bits per inch to 75 BPI. OR Select 128 BPI to change the bits per inch to 128 BPI. OR Select 210 BPI to change the bits per inch to 210 BPI.

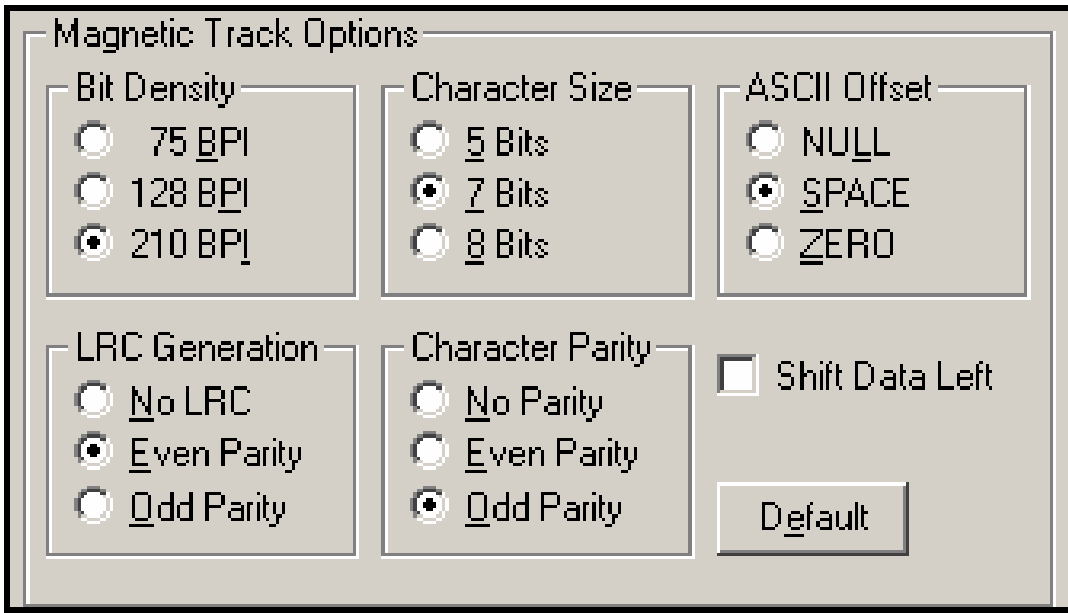

Using the Character Size radio buttons

Use this option to customize the Character Data Size (Bits per Character) used to encode the magnetic data on the currently selected track. **(Note:** This character size includes the parity bit (if enabled).)

Step	Procedure
1	Select 5 Bits to change the bits per character to 5 BPC. OR Select 7 Bits to change the bits per character to 7 BPC. OR Select 8 Bits to change the bits per character to 8 BPC.



Reviewing the Enable MLE Support checkbox

Multi-Language Extension (MLE) support in Windows XP can cause text strings to be broken up into fragments. This fragmentation of the text string prevents magnetic encoding. (**Note:** This option may help correct encoding problems in all operating systems.)

Step	Procedure
1	Check this box to allow the Driver to process the fragmented text.

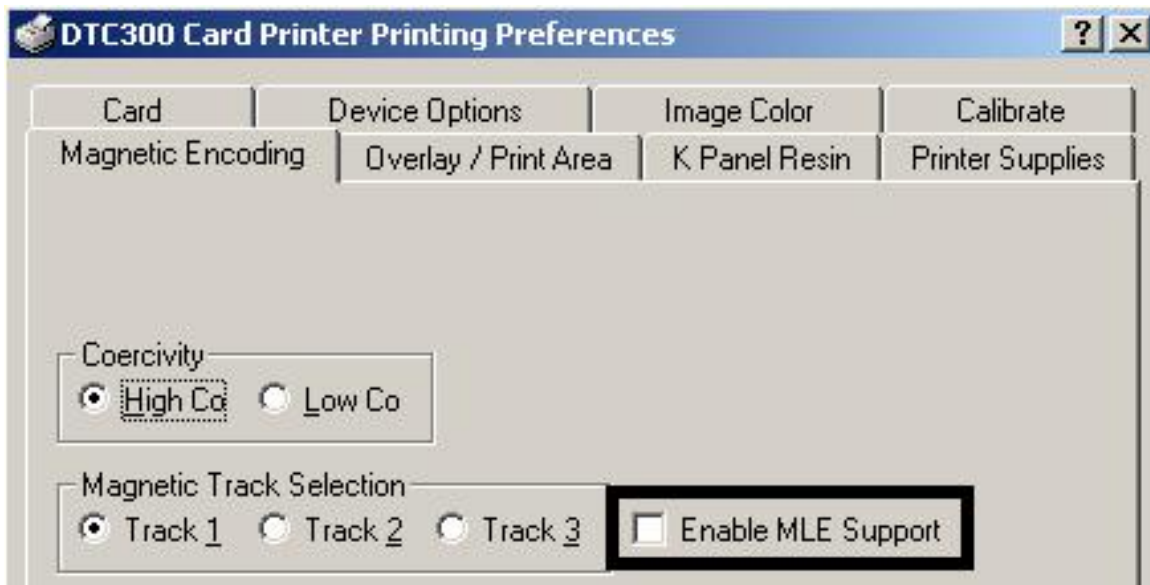

Using the ASCII Offset radio buttons

Use this option to customize the Character ASCII Offset used to encode the magnetic data on the currently selected track. (**Note:** This character offset value is subtracted from the ASCII value of each Magnetic Stripe data character prior to encoding on the track.)

Step	Procedure
1	Select NULL to change the ASCII Offset to NULL. OR Select SPACE to change the ASCII Offset to SPACE. OR Select ZERO to change the ASCII Offset to ZERO.



Using the LRC Generation radio buttons

Use this option to customize the LRC Generation Mode (used to encode the magnetic data on the currently selected track).

Step	Procedure
1	Select NO LRC to change the LRC Generation to none. OR Select Even Parity to change the LRC Generation to Even Parity. OR Select Odd Parity to change the LRC Generation to Odd Parity.

Using the Character Parity radio buttons

Use this option to customize the Character Data Parity (used to encode the magnetic data on the currently selected track).

Step	Procedure
1	Select No Parity to change the Character Parity to none. OR Select Even Parity to change the Character Parity to Even Parity. OR Select Odd Parity to change the Character Parity to Odd Parity

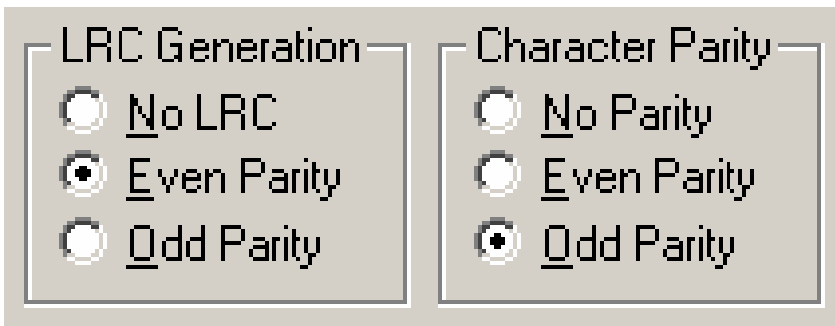

Using the Shift Data Left checkbox

Use this option to shift the recorded magnetic data to the left-hand side of the card's Magnetic Stripe.

OR

Use this option for situations that require cards to be readable with insert type readers that may be unable to read the right-hand side of the card.

Step	Procedure
1	Select the Shift Data Left checkbox option to apply to all tracks.

Magnetic Track Options

Bit Density

75 BPI

128 BPI

210 BPI

Character Size

5 Bits

7 Bits

8 Bits

ASCII Offset

NULL

SPACE

ZERO

LRC Generation

No LRC

Even Parity

Odd Parity

Character Parity

No Parity

Even Parity

Odd Parity

Shift Data Left

Default

Reviewing the ISO Track Locations

Review the magnetic encoding module, which encodes onto tracks in accordance with an ISO 7811-2 Magnetic Stripe. (**Note:** Refer to the diagram (below) for track locations.)

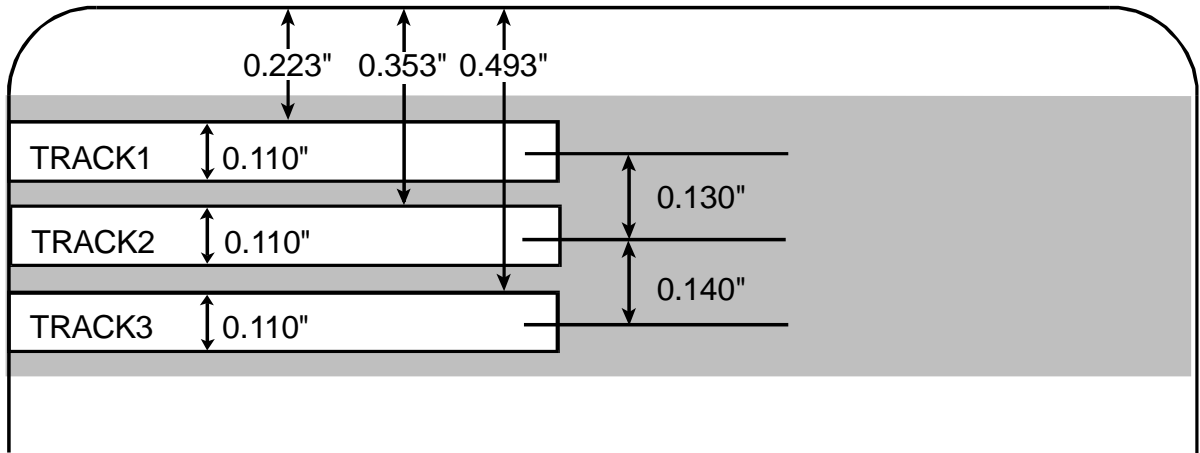

Sending the Track Information

Magnetic track data is sent in the form of text strings from the application software to the Printer Driver along with all of the other printable objects within the card design.

- **Magnetic Track Data added:** In order for the Printer Driver to differentiate between magnetic track data and the rest of the printable objects, the magnetic track data strings must be uniquely tagged or added.
- **Specific Characters added:** In other words, specific characters must be added to the magnetic track data in order for the Printer Driver to know which data is to be encoded, which tracks to encode, when the track data stops and starts and so forth.
- **Manually or automatically added:** In some cases, these specific characters are automatically added to the string of track data by customized ID software applications. In most cases, however, the User must manually add these characters to the string of magnetic track data.

Entering the Track Information

(**Note:** If these characters are not added to the track data, the text intended for the magnetic track will most likely appear as printed text on the card.)

Step	Procedure
1	<p>To avoid this symptom, track information must be entered as follows.</p> <p>When entering track data, the "~" character is entered first, followed by the desired track number (1, 2, or 3) used to encode the data.</p> <ul style="list-style-type: none"> • The data to be encoded should then follow. (Note: The first character of this data string must be the track's specific Start Sentinel (SS) and the last character must be the specific End Sentinel (ES).) • The characters or data in between the SS and ES can include all of the valid characters specific to each track. (Note: The number of these characters is limited by each track's maximum character capacity.) <p> Caution: When segmenting track data, strictly use the appropriate Field Separator (FS).</p>

Reviewing Tracks 1, 2 and 3 (in table format)

Review this table, which displays the SS, ES, FS and the valid characters defined for each track.

	Start Sentinel	End Sentinel	Field Separator	Valid Characters	Maximum Number of Characters
Track 1	%	?	^	ASCII 32-95 (See the table below.)	78
Track 2	;	?	=	ASCII 48-63 (See the table below.)	39
Track 3	;	?	=	ASCII 48-63 (See the table below.)	106

Reviewing the Track Data Note

Review this Note, which displays how track the data should be entered for Tracks 1, 2 and 3:

Track	Data Entry
Sending data to Track 1	~1%JULIE ANDERSON^623-85-1253?
Sending data to Track 2	~2;0123456789?
Sending data to Track 3	~3;0123456789?

Reviewing the ASCII Code and Character Table

ASCII Code	Character	ASCII Code	Character	ASCII Code	Character
32	space	56	8	80	P
33	!	57	9	81	Q
34	"	58	:	82	R
35	No.	59	;	83	S
36	\$	60	<	84	T
37	%	61	=	85	U
38	&	62	>	86	V
39	'	63	?	87	W
40	(64	@	88	X
41)	65	A	89	Y
42	*	66	B	90	Z
43	+	67	C	91	[
44	,	68	D	92	\
45	-	69	E	93]
46	.	70	F	94	^
47	/	71	G	95	_
48	0	72	H		
49	1	73	I		
50	2	74	J		
51	3	75	K		
52	4	76	L		
53	5	77	M		
54	6	78	N		
55	7	79	O		

Using the Overlay / Print Area tab

Use this option to control where the Overlay (O) Panel and/or the print area appear on a card. (**Note:** This option is helpful if, for example, you would like to omit or block out the overlay or printing around a card's smart chip or Magnetic Stripe.)

- By default, this option is set to print and overlay the entire card. To customize the overlay and/or print area, select one of the options listed under "Overlay / Print Area."

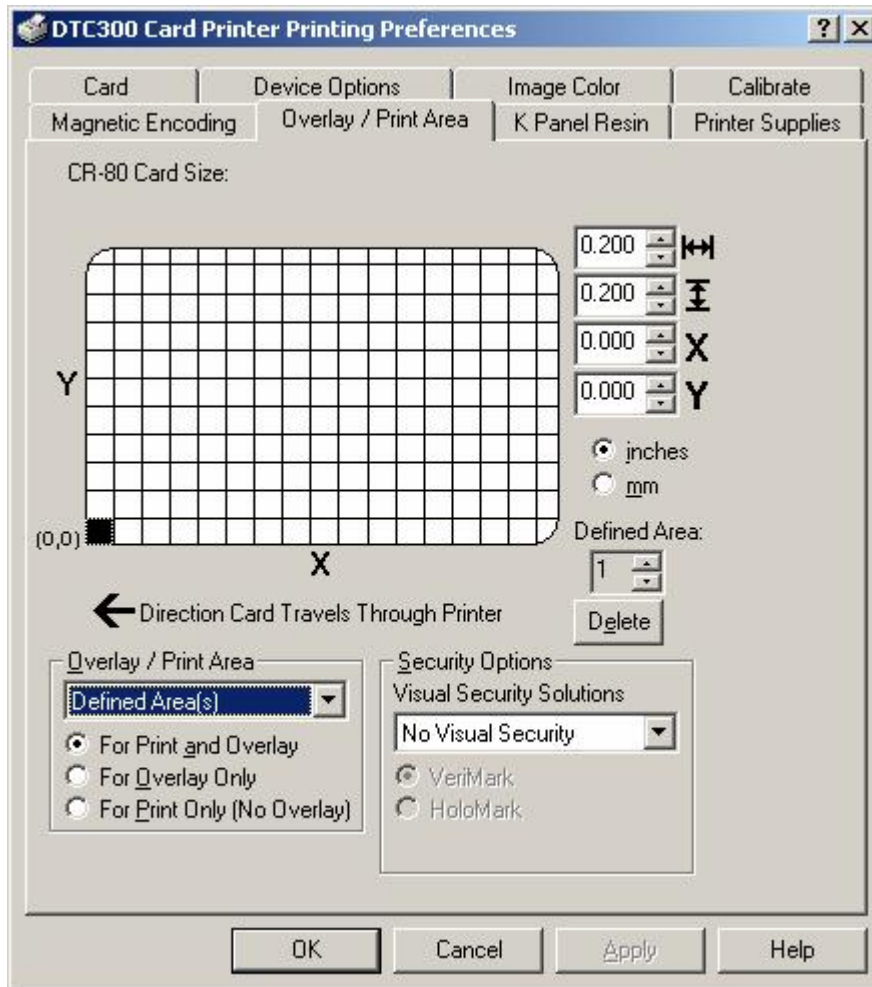

Using the Overlay / Print Area dropdown menu

Step	Procedure
1	<p>Select the Full Card option for the Printer to overlay and/or print the entire card.</p> <p>OR</p> <p>Select the Defined Area(s) option for the Printer to overlay and/or print only in the selected and defined area or areas.</p> <p>OR</p> <p>Select the Undefined Area(s) option for the Printer to overlay and/or print only in the space outside the selected and defined area.</p> <p>OR</p> <p>Select the Omit Smart Chip Area option for the Printer to overlay and/or print only in the space outside the standard location of a smart chip.</p> <p>OR</p> <p>Select the Omit Magnetic Stripe Area option for the Printer to overlay and/or print only in the space outside the standard location of an ISO Magnetic Stripe.</p> <p>OR</p> <p>Select the Omit Signature Area option for the Printer to overlay and/or print only in the space outside the standard location of a signature panel.</p> <p>(Note: In the card grid, black indicates the area in which the overlay and/or printing will be applied.)</p>

Continued on the next page

Using the Overlay / Print Area dropdown menu (continued)

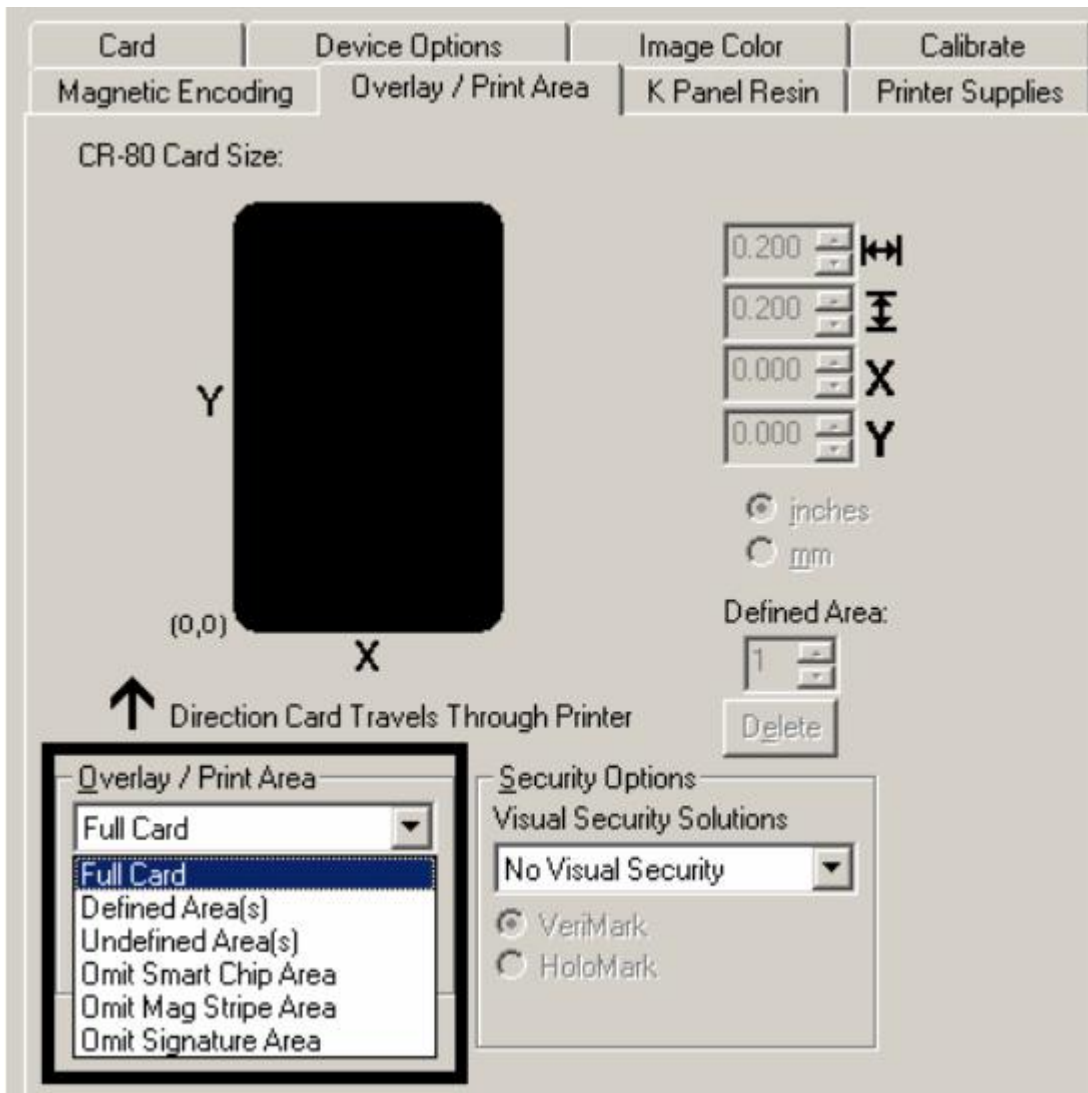

Using the Overlay / Print Area

Use these **Overlay / Print Area** options to control both the print and overlay together or control each individually.

Step	Procedure
1	<p>Select For Print and Overlay for the defined area to apply to both the printing and overlay process.</p> <p>OR</p> <p>Select For Overlay Only for the defined area to apply only to the overlay process. (Note: In this mode, printing will still be allowed over the entire card and only the overlay will be affected.)</p> <p>OR</p> <p>Select For Print Only (No Overlay) for the defined area to apply only to the print process. (Important: In this mode, the overlay is completely disabled so it will not be applied.)</p> <p> Caution: An overlay or an overlamine must protect dye-sublimation printing or it will quickly begin to wear or fade.</p>

Continued on the next page

Using the Overlay / Print Area (continued)

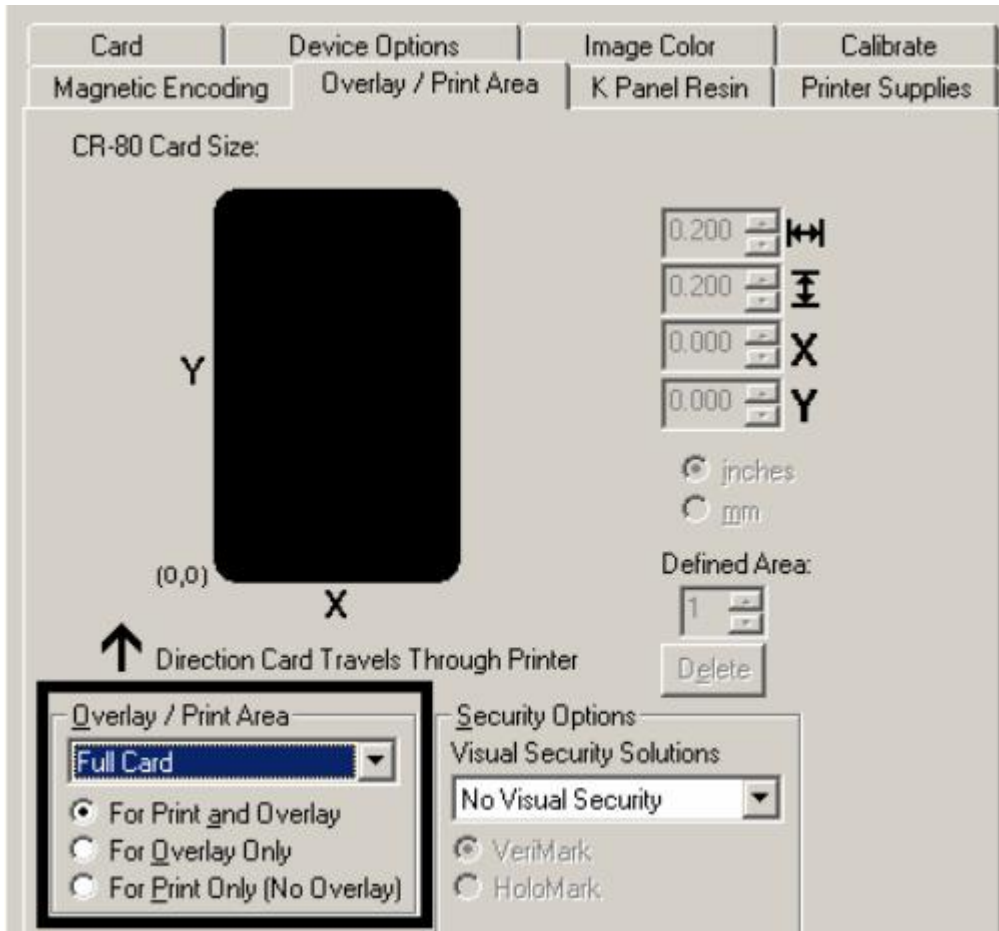

Using the Defined Area Option

Step	Procedure
1	Select the Defined Area(s) option to activate the card grid in the upper half of the window. It is through this card grid that up to five (5) Defined Areas can be assigned.

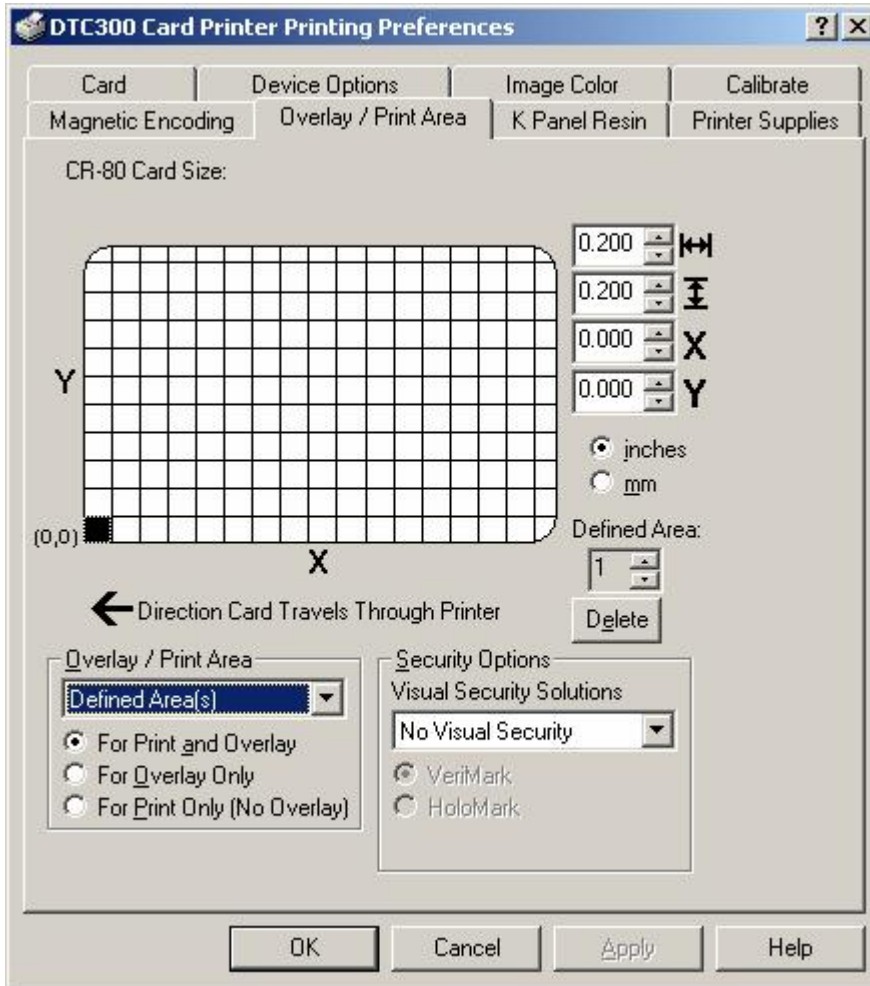

Using the Defined Area Option (continued)

Step	Procedure
2	<p>When the card grid is first activated, a small black square will appear at its default size of .2" x .2" / 5mm x 5mm and at its default location in the lower left-hand corner (0, 0). This square represents the first defined area.</p> <ul style="list-style-type: none"> • Determine the area of the card needed to define for a signature panel with a different size and location than the Driver's standard Omit Signature Area setting. (Note: This area is indicated by the dashed outline.) • Determine the area size by actually printing a card and looking at it in the same orientation as when it exits the Printer.
3	<p>Measure the total size of the desired area and enter those dimensions into the dimension boxes. (Note: The minimum size an area is .2" x .2" / 5mm x 5mm.)</p>

Continued on the next page



Using the Defined Area Option (continued)

Step	Procedure
4	Measure from the lower left corner of the card up and over to the lower left corner of for the defined area to begin and enter these values into the X and Y boxes. (Note: The card grid lines are spaced at .2 inch / 5mm intervals.)

Continued on the next page

CR-80 Card Size:

Y

(0,0)

X

← Direction Card Travels Through Printer

0.200

0.200

0.000

0.000

inches

mm

Defined Area:

1

Delete

Using the Defined Area Option (continued)

Step	Procedure
5	<p>a. Print the card design and observe how the image is oriented on the card as it ejects from the Printer. (Note: The location of a defined area is based on the card orientation as it exits the Printer.)</p> <p>b. Measure the defined area location based on the printed card. (Note: If selecting the Rotate Front 180 Degrees option, the image will appear upside down as it exits the Printer.)</p> <p>c. Position the defined area opposite to the measurement of the onscreen card design (which will appear right side up).</p>

Continued on the next page



Using the Defined Area Option (continued)

Step	Procedure
6	<p>Use the Defined Area arrows to navigate back and forth from area to area. (Note: The active area will always be highlighted with a dotted outline.)</p> <p>a. Define another area by clicking on the Defined Area UP arrow.</p> <ul style="list-style-type: none"> • Another .2" x .2" / 5mm x 5mm area will appear in the lower left-hand corner. (Note: This is the location in which all newly defined areas will first appear.) • Up to 5 areas can be defined; however, additional areas cannot be added until the most recently created area has been moved or sized. (Note: For this reason, size and position each area as it is created.) <p>b. Delete an area by using the Defined Area arrows to select the area and click on the Delete button. (Note: If all areas are deleted, the K Panel Resin options will automatically be deselected.)</p>

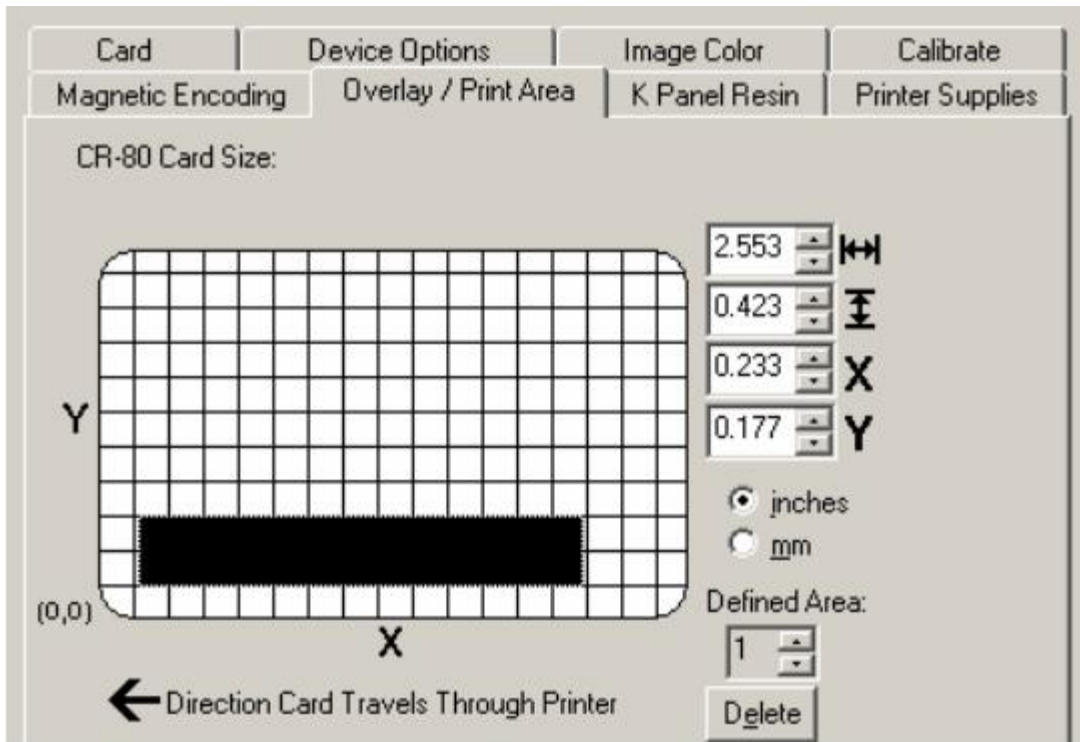

Using Security Options (Visual Security Solutions)

The Visual Security Solutions dropdown menu list will be used to enable and select which type of visual security will be used. The Visual Security dropdown list will be selectable only on the Front side (see below). Visual Security is not an option for the back side.

The following actions will occur when one of the Visual Security locations is selected.

- The Overlay / Print Area will be disabled.
- The Security Options become selectable.

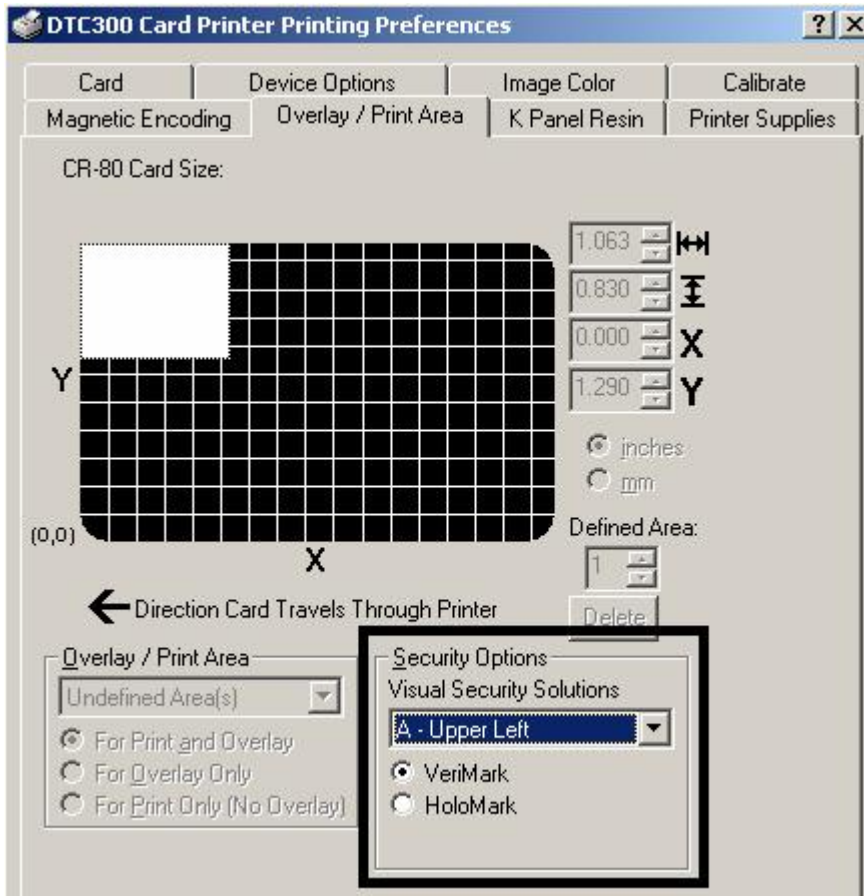

Selecting Orientation - Landscape under Card tab

Step	Procedure
1	Select the Landscape radio button (below) under Orientation under the Card Size tab to use the Visual Security Solutions (A to D), as shown in this window.

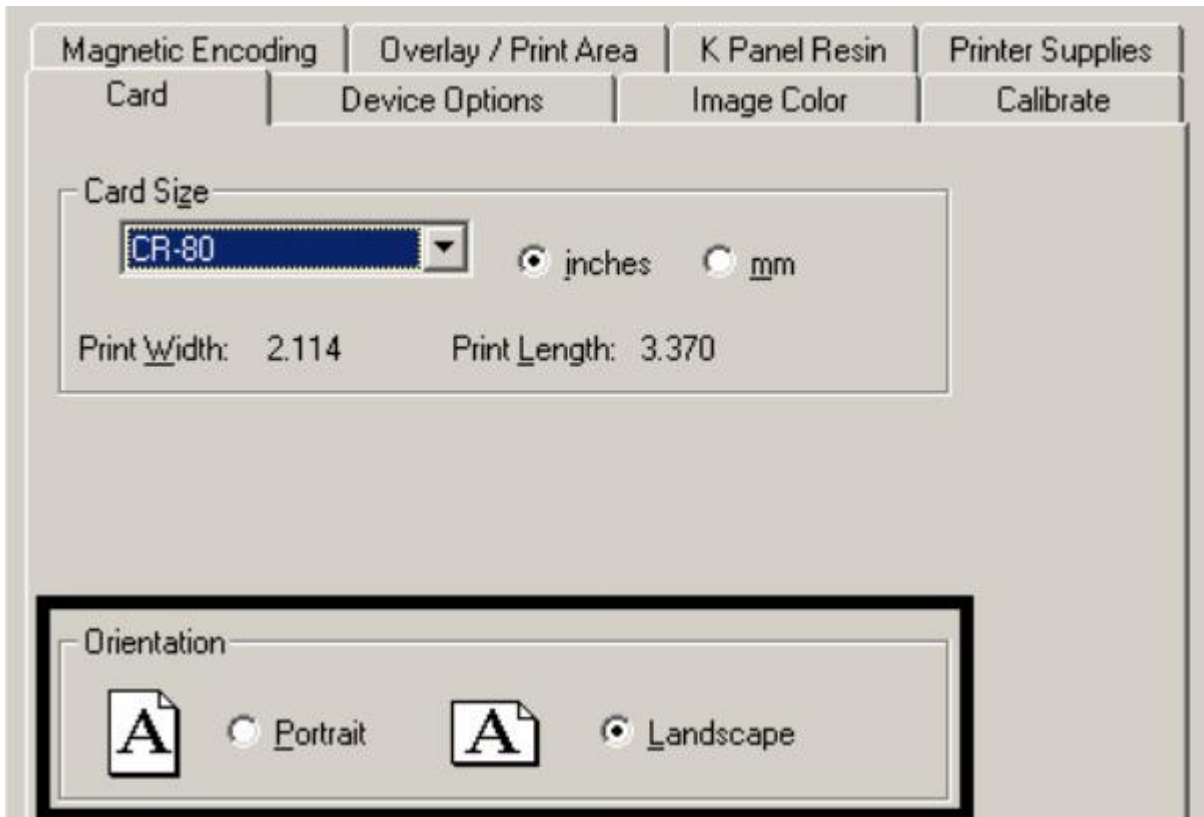

Selecting the Visual Security Solutions dropdown menu (A to D)

Step	Procedure
1	Click on the Visual Security Solutions dropdown menu (below) under the Landscape - Orientation (see above) to use the options shown in this display.

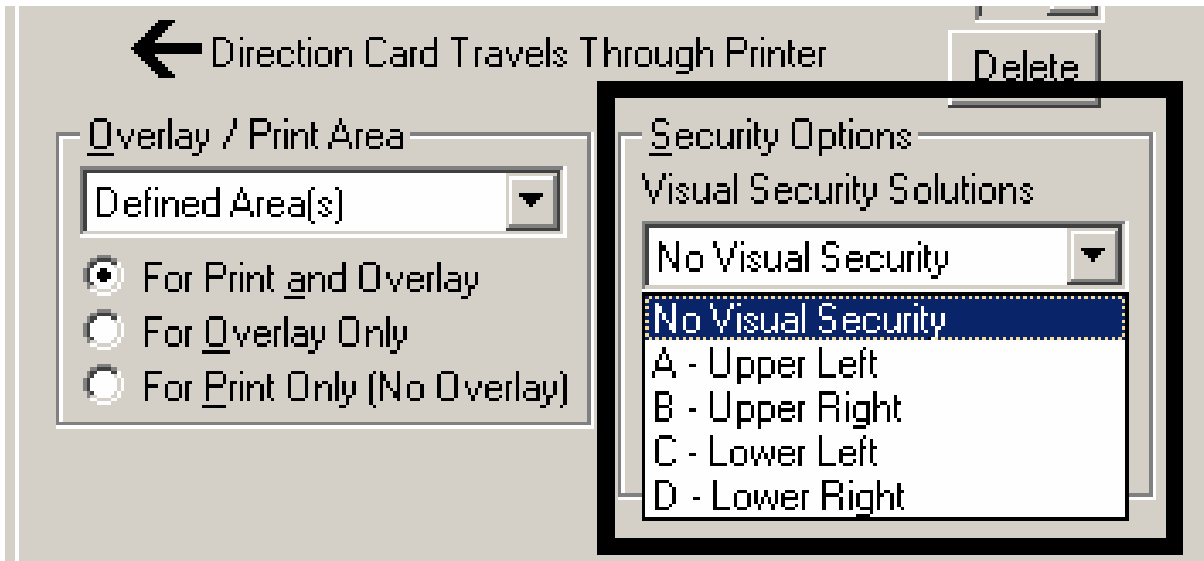

Selecting Orientation - Portrait under Card tab

Step	Procedure
1	Select the Portrait radio button (below) under Orientation under the Card Size tab to use the Visual Security Solutions (E to H), as shown in this window.

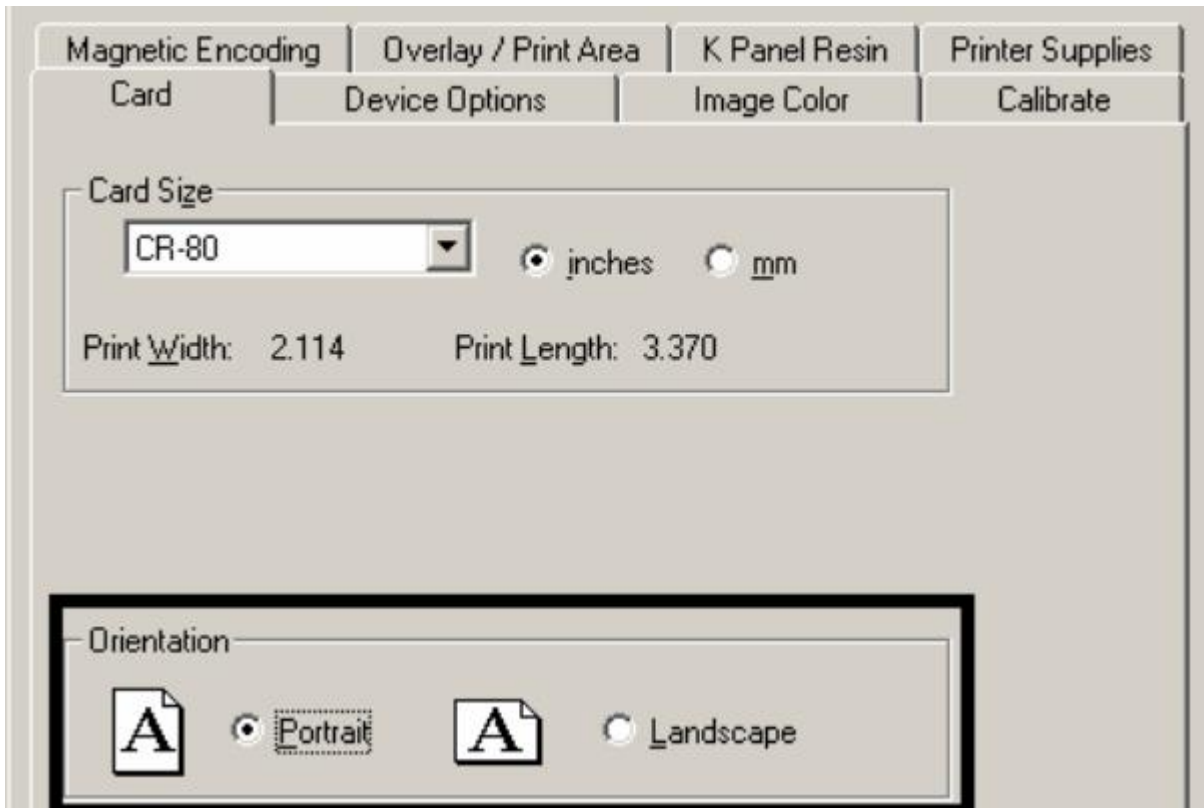

Selecting the Visual Security Solutions dropdown menu (E to H)

Step	Procedure
1	Click on the Visual Security Solutions dropdown menu under the Portrait - Orientation (see above) to use the options shown below.

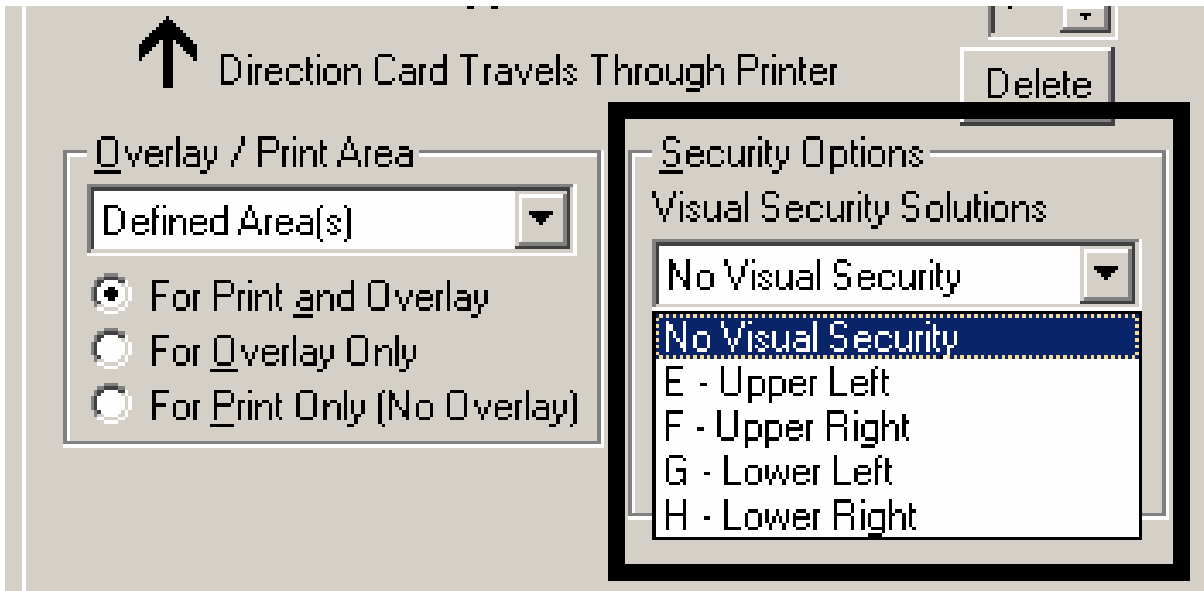

Selecting the VeriMark radio button

Step	Procedure
1	Click on either the VeriMark or HoloMark radio button, as shown below. The foil options are used to control the size of the exclusion area. (Note: When VeriMark is selected a rectangle-sized area is excluded, HoloMark uses a square sized area.)
2	Click on the VeriMark radio button (below) for the rectangle-sized area.

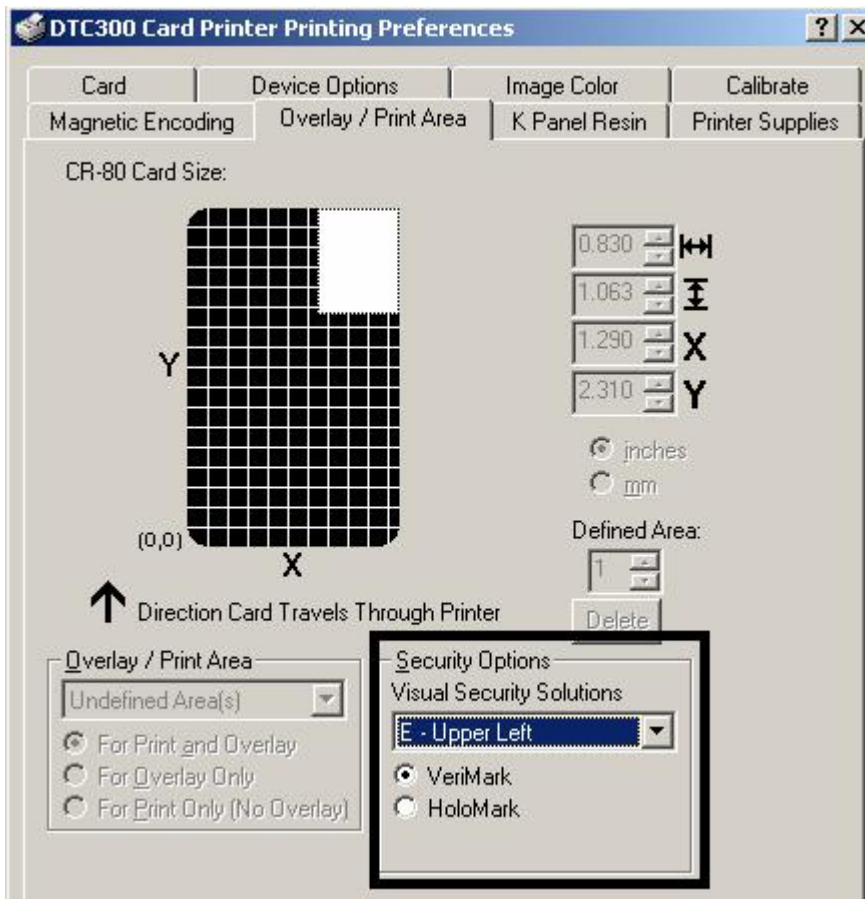

Selecting the HoloMark radio button

Step	Procedure
1	Click on the HoloMark radio button (below) for the squared-area size.

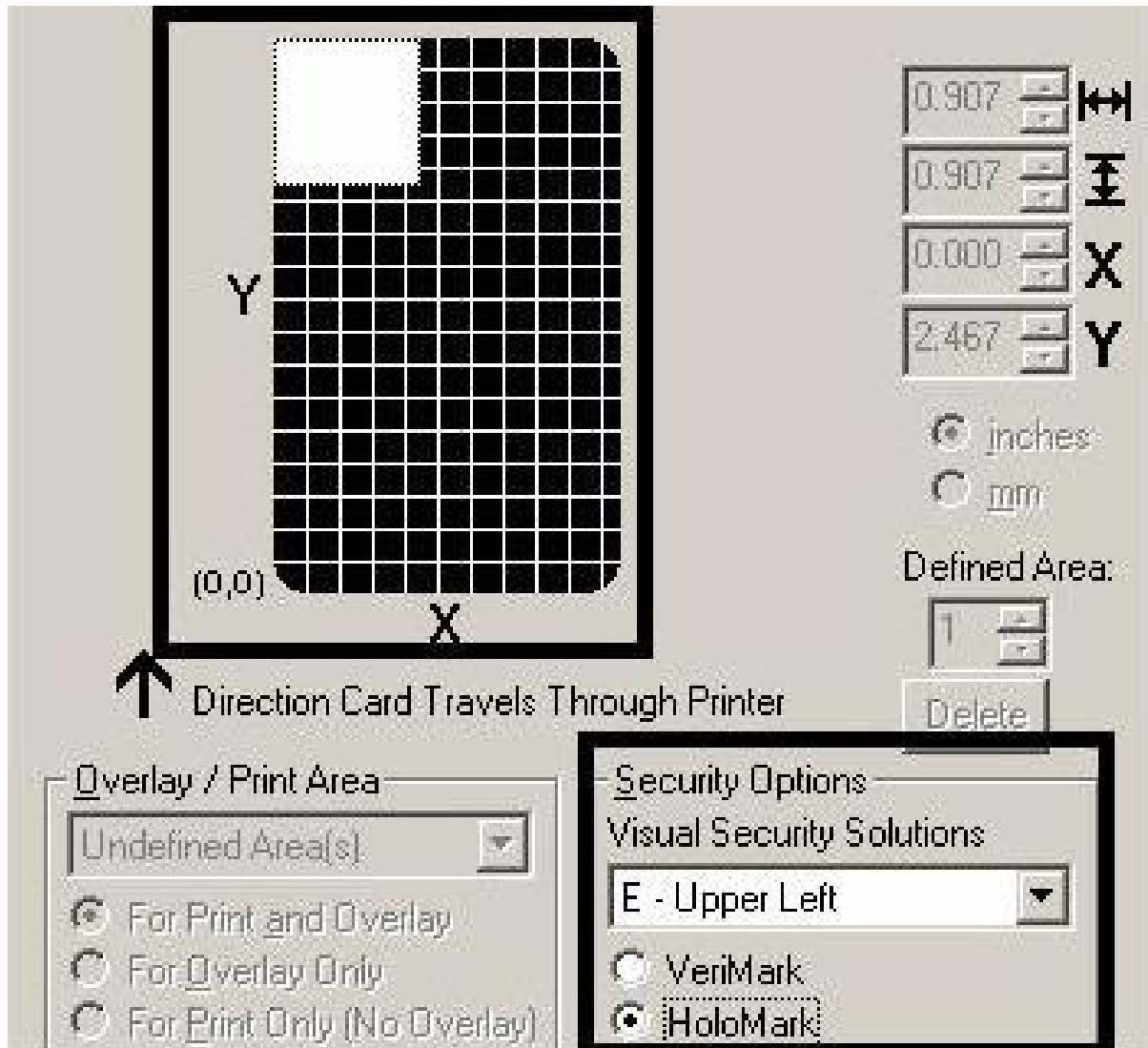

Reviewing the Custom VeriMark Card (Custom Graphic in a 2D foil)

The custom VeriMark image is stamped on blank, standard-sized cards. You can select one of eight positions (A to H), as shown in the Portrait and Landscape samples below.

Sample 1: VeriMark Card (Landscape - Orientation) - 4 positions (below)

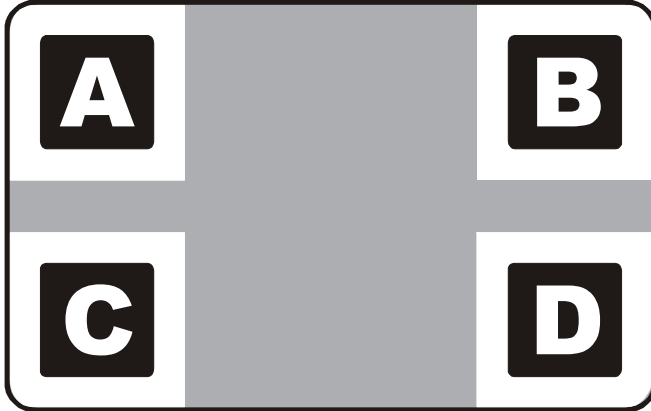

Sample 2: VeriMark Card (Portrait - Orientation) - 4 positions (below)

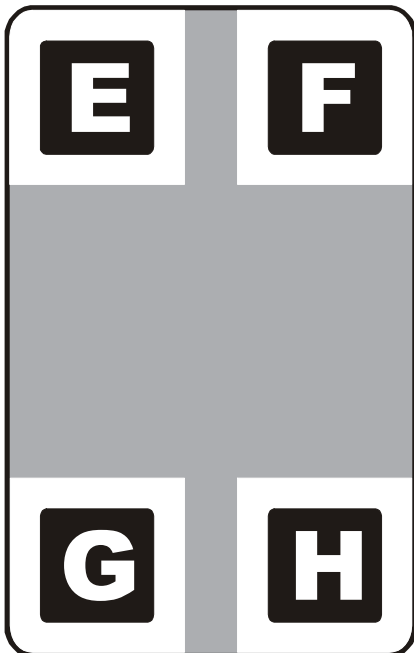

Reviewing the Custom HoloMark Card (Custom Graphic in a 2D foil)

The custom HoloMark image is stamped on blank, standard-sized cards. You can select one of eight positions (A to H), as shown in the Portrait and Landscape samples below.

Sample 1: HoloMark Card (Landscape - Orientation) - 4 positions (below)

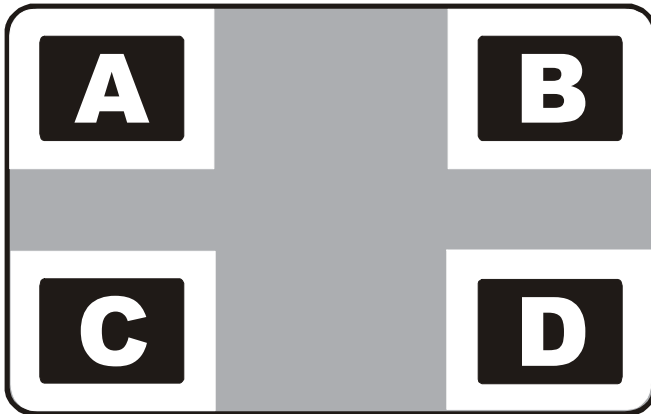

Sample 2: HoloMark Card (Portrait - Orientation) - 4 positions (below)

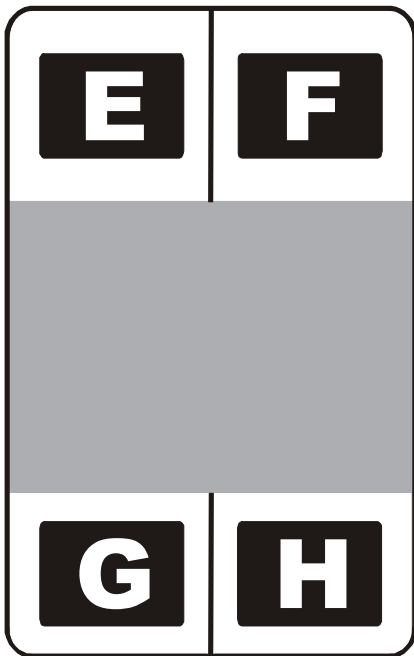

Using the K Panel Resin tab

Select the **K Panel Resin** option to control where the resin black (K) panel of a full-color Ribbon is printed.

- If printing with a resin-only Ribbon type all K Panel Resin options will be grayed out.
- Resin black text is desirable due to its sharp, saturated black coloring and resin black bar codes are often required by Ultra Violet barcode readers to ensure readability when scanned.)

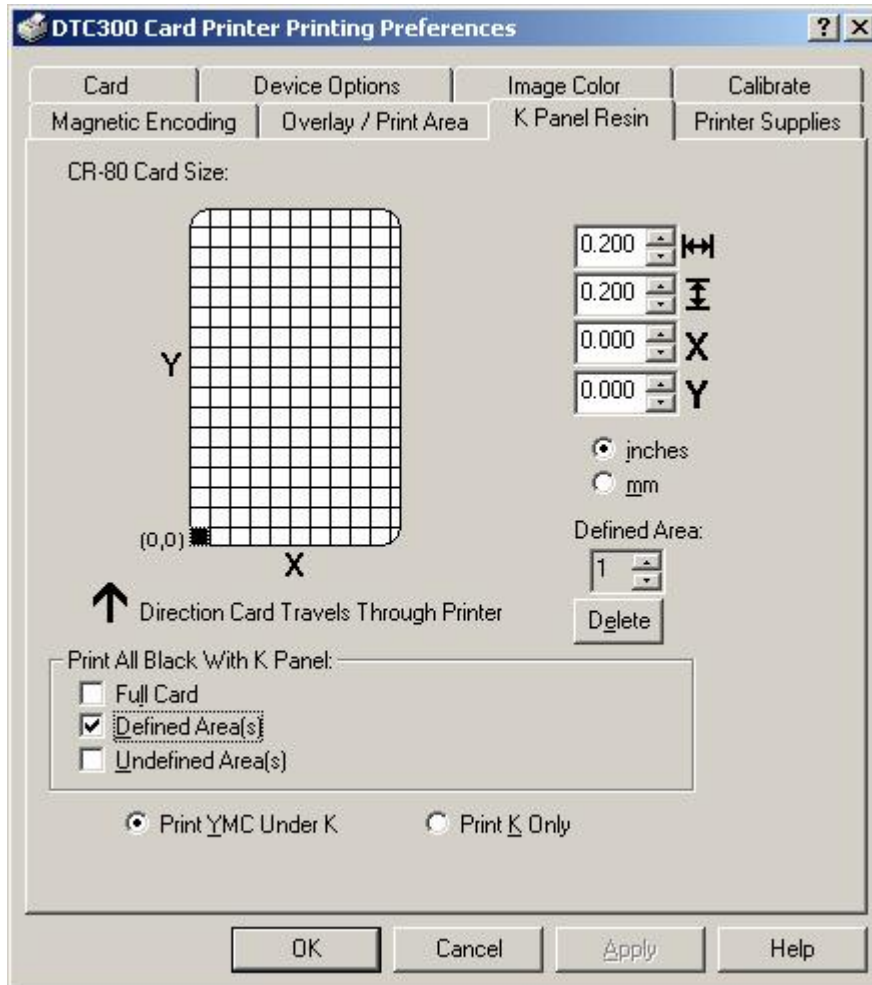

Selecting from the Print All Black With K Panel options

Select one of the three options listed under **Print All Black With K Panel** if the black text or bar codes are not TrueType fonts and/or are not printing with the resin black panel. **(Note:** The Printer Driver will print areas of the image where it finds black coloring with the print Ribbon's resin black (K) panel as specified by each of the following options.

Step	Procedure
1	When none of the options within this window are selected, the Printer Driver will automatically print all TrueType black text and bar codes only with the Resin Black (K) Panel of the print Ribbon.

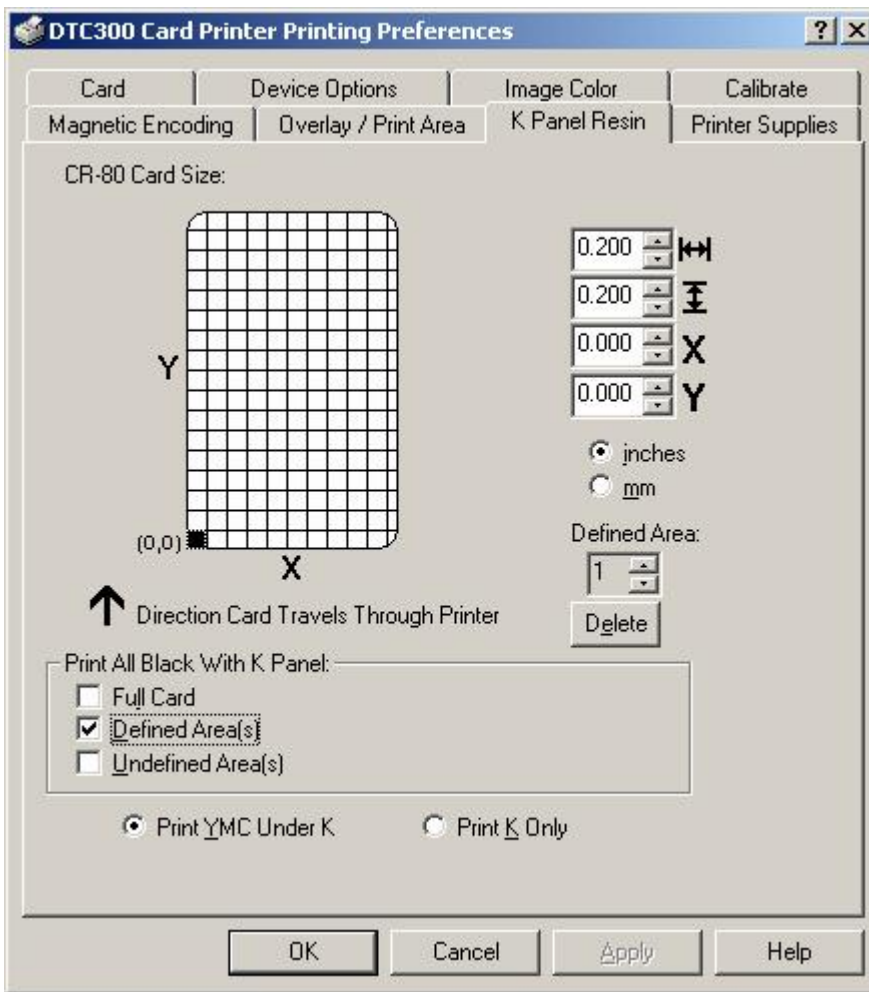

Selecting the Full Card option

Step	Procedure
1	Select the Full Card option for the Printer Driver to print the resin black (K) panel for all black found within all areas of the image.

CR-80 Card Size:

Y

(0,0)

X

↑ Direction Card Travels Through Printer

0.200

0.200

0.000

0.000

inches

mm

Defined Area:

1

Delete

Print All Black With K Panel:

- Full Card
- Defined Area(s)
- Undefined Area(s)

Print YMC Under K Print K Only

Selecting the Defined Area(s) option

Step	Procedure
1	Select the Defined Area(s) option for the Printer Driver to print the resin black (K) panel for all black found only in a desired and defined area or areas.

CR-80 Card Size:

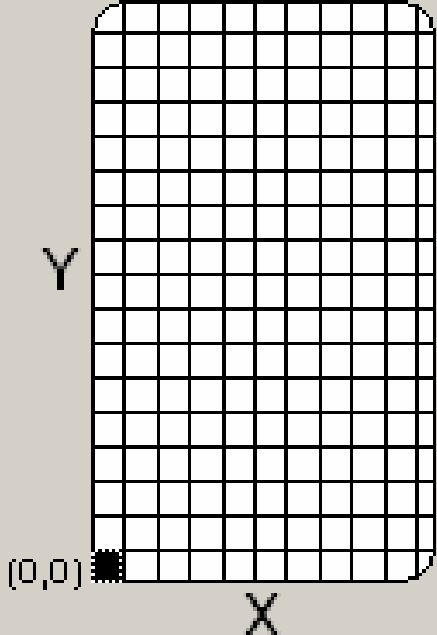

Y

X

(0,0)

↑ Direction Card Travels Through Printer

0.200

0.200

0.000

0.000

inches

mm

Defined Area:

1

Delete

Print All Black With K Panel:

- Full Card
- Defined Area(s)
- Undefined Area(s)

Print YMC Under K Print K Only

Selecting the Undefined Area(s) option

Step	Procedure
1	Select the Undefined Area(s) option for the Printer Driver to print the resin black (K) panel for all black found only in the space outside the defined areas. (Note: In the card grid, black indicates the area in which the resin black (K) panel will be printed.)

CR-80 Card Size:

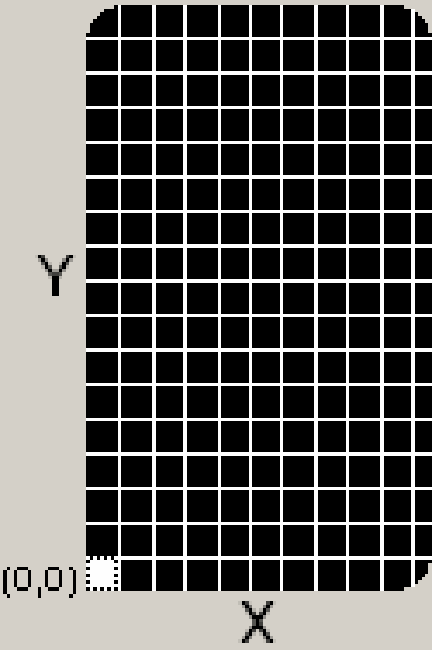

Y

(0,0)

X

↑ Direction Card Travels Through Printer

0.200

0.200

0.000

0.000

inches

mm

Defined Area:

1

Delete

Print All Black With K Panel:

- Full Card
- Defined Area(s)
- Undefined Area(s)

Print YMC Under K

Print K Only

Selecting the Defined Area(s) function

To define an area, refer to the following steps:

Step	Procedure
1	<p>Click on the Defined Area(s) check box. (Note: This will activate the card grid in the upper half of the window. It is through this card grid that up to five areas can be defined.)</p> <p>When the card grid is first activated, a small square will appear at its default size of .2" x .2" / 5mm x 5mm and at its default location in the lower left-hand corner (0,0). This square represents the first defined area.</p> <p>(Note: Changing the orientation of the card in the Card Tab will change the appearance of this Tab.)</p>

Continued on the next page

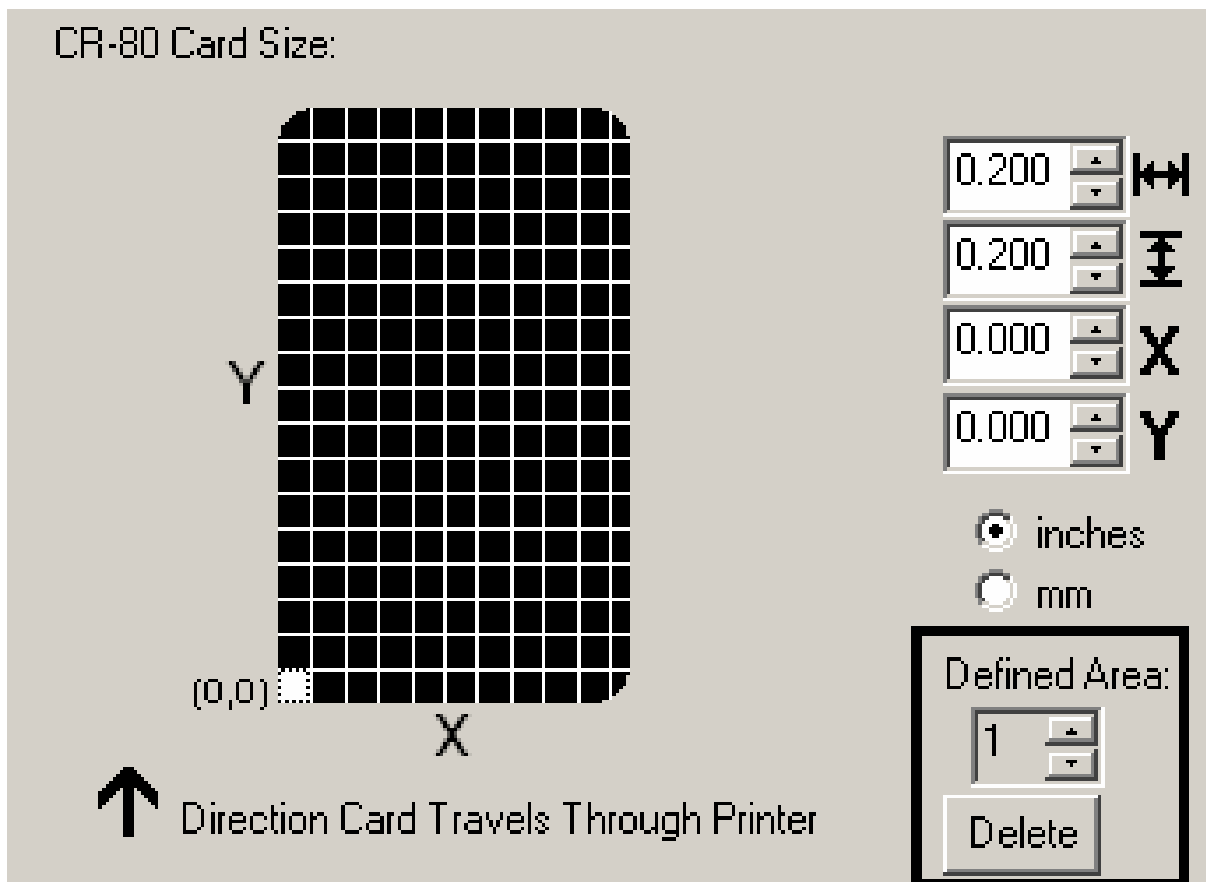

Selecting the Defined Area(s) function (continued)

Step	Procedure
2	a. Determine the area of the card necessary to define. In the sample (below), this area is indicated by the dashed outline. b. Determine the size of this area by actually printing a card and looking at it in the same orientation as when it exits the Printer.
3	Measure the total size for the area and enter those dimensions into the dimension boxes. (Note: The minimum size an area can be is .2" x .2" / 5mm x 5mm.)

Continued on the next page

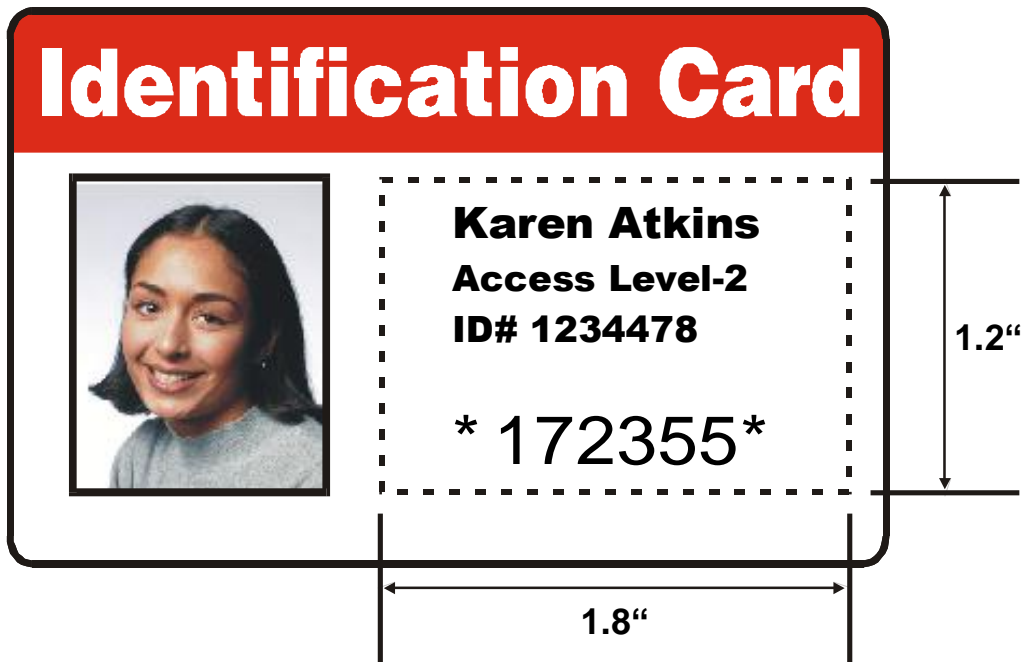

Selecting the Defined Area(s) function (continued)

Step	Procedure
4	a. Once the area is sized properly measure from the lower left corner of the card up and over to the lower left corner for the defined area to begin. b. Enter these values into the X and Y boxes. (Note: The card grid lines are spaced at .2 inch / 5mm intervals.)
5	a. Print the card design and note how the image is oriented on the card as it ejects from the Printer. (Note: The location of a defined area is based on the card orientation as it exits the Printer.) b. Measure the defined area location based on the printed card. (Note: If selecting the Rotate Front 180 Degrees option, the image will appear upside-down as it exits the Printer. In this case, position the defined area opposite to the measurement from the onscreen card design, which will appear right side up.)

Continued on the next page

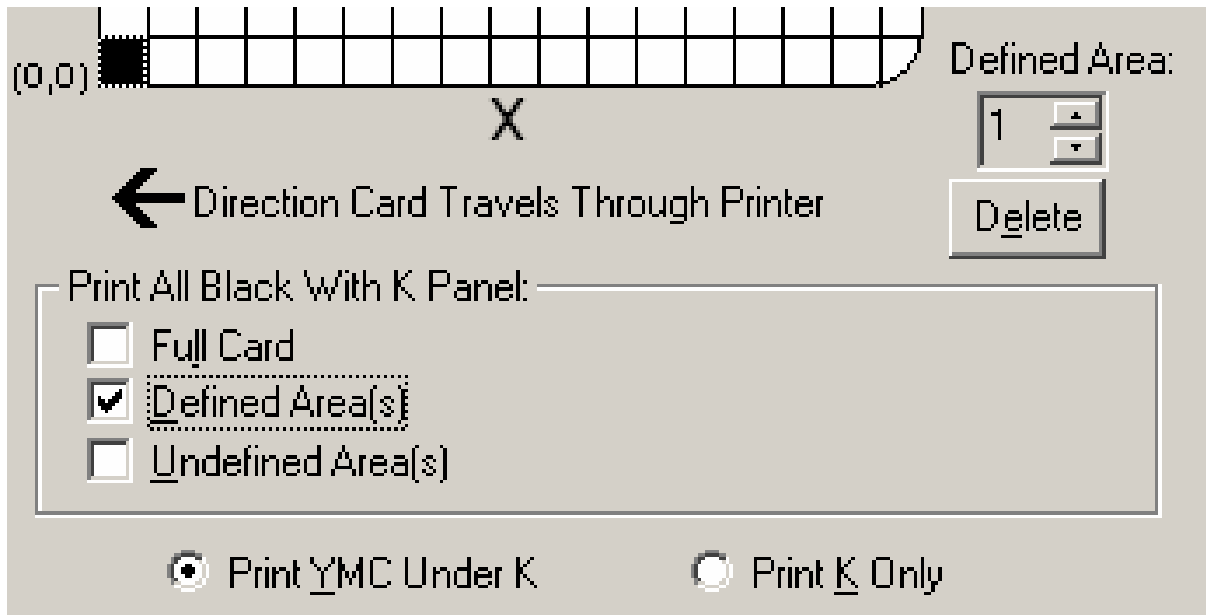

Selecting the Defined Area(s) function (continued)

Refer to the previous procedure.

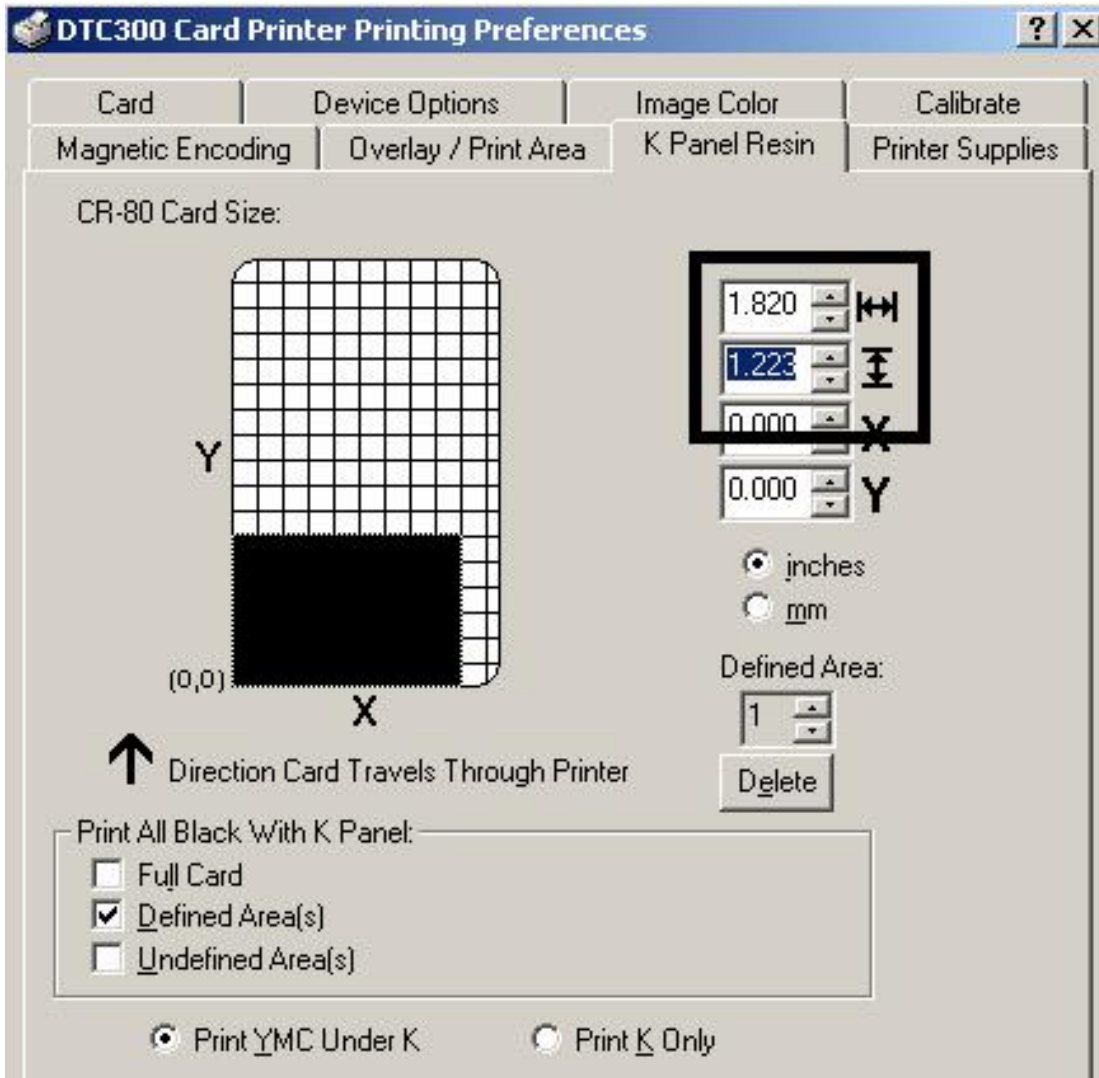

Continued on the next page

Selecting the Defined Area(s) function (continued)

Refer to the previous procedure.



Continued on the next page

Selecting the Defined Area(s) function (continued)

Refer to the previous procedure.

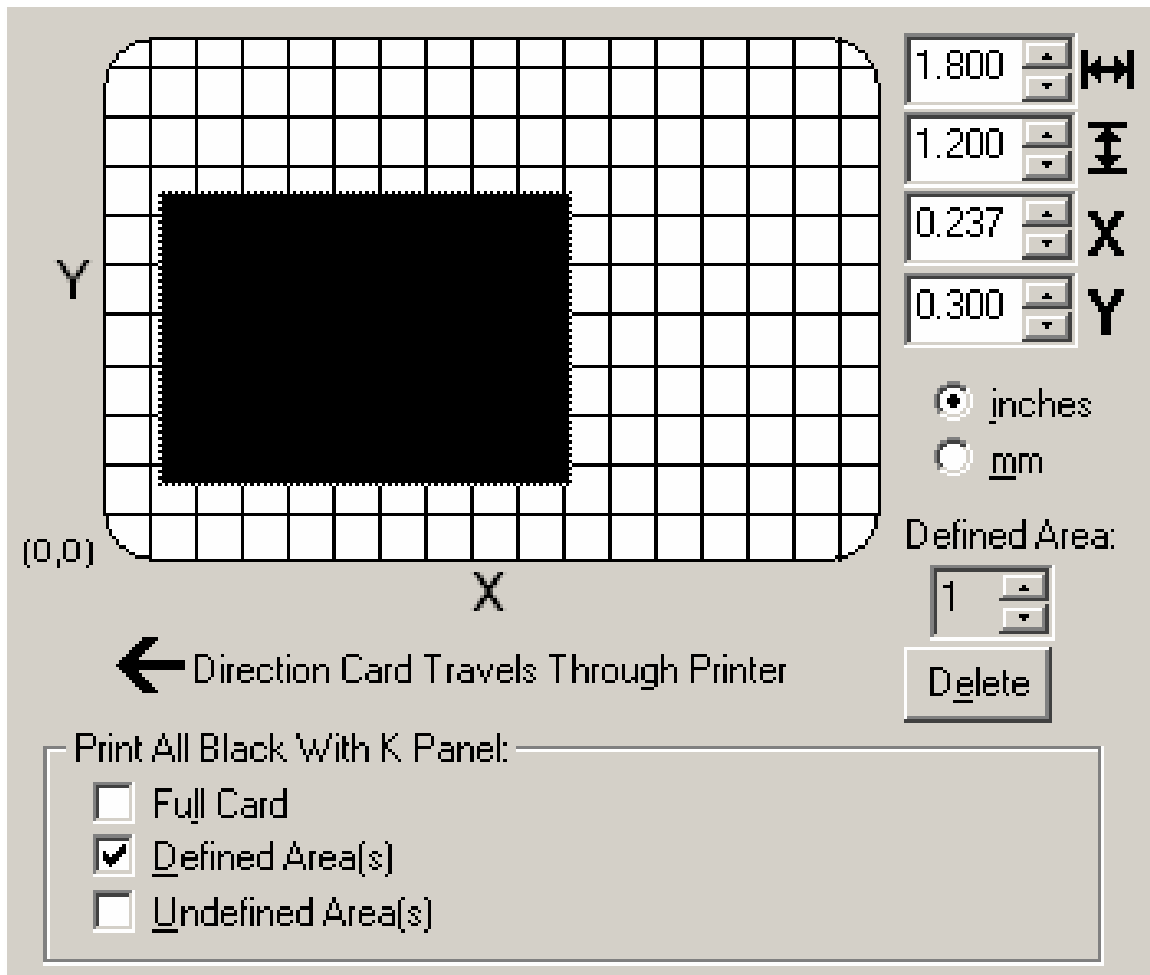

Continued on the next page

Selecting the Defined Area(s) function (continued)

Step	Procedure
6	Define another area by clicking on the Defined Area up arrow. (Note: Another .2" x .2" / 5mm x 5mm area will appear in the lower left-hand corner. This is the location in which all newly defined areas will first appear.)
7	Use the Defined Area arrows to navigate back and forth from area to area. (Note: The active area will always be highlighted with a dotted outline. Up to 5 areas can be defined.) Size and position each area as it is created because additional areas cannot be added until the most recently created area has been moved or sized.
8	Delete an area by using the Defined Area arrows to select the area and clicking on the Delete button. (Note: If all areas are deleted, the K Panel Resin options will automatically be deselected.)

Continued on the next page

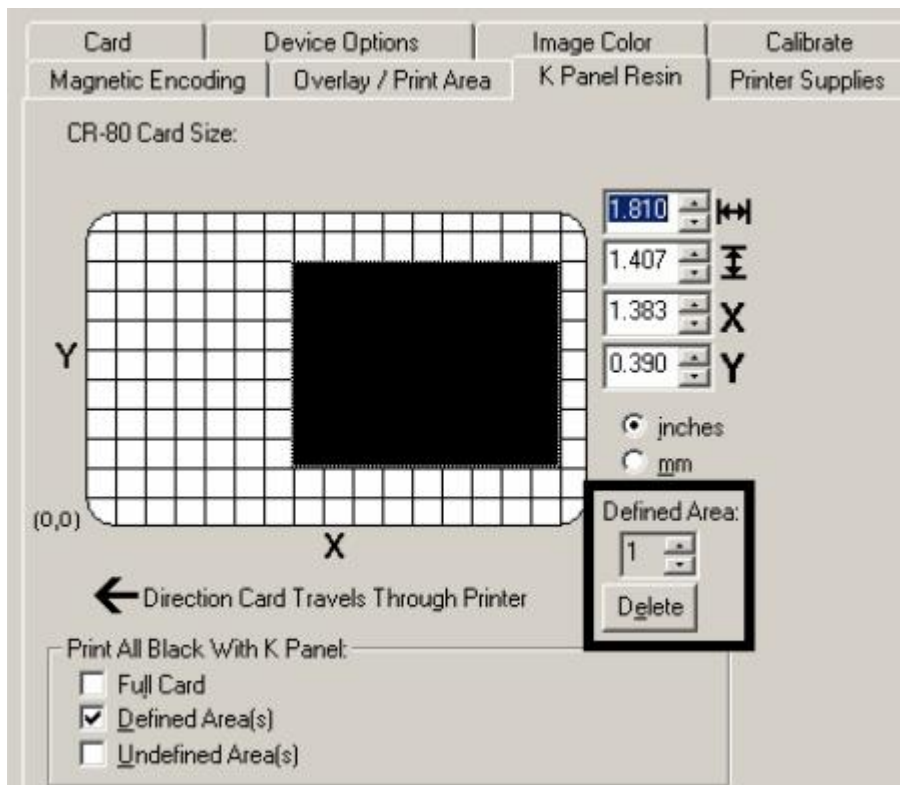

Selecting the Print YMC under K and Print K Only options

Step	Procedure
1	<ul style="list-style-type: none"> • Select between the Print YMC Under K and Print K Only options. (Note: When the Print YMC Under K option is selected, all black in the designated areas will print with the Yellow (Y), Magenta (M) and Cyan (C) Ribbon panels directly beneath the resin black (K) panel.) <p>OR</p> <ul style="list-style-type: none"> • Select this option if printing resin black text or bar codes onto a colored background to provide a more gradual transition between the two.
2	<p>Select the Print K Only option if printing resin black onto a white background to maximize the sharpness of printed text and bar codes. (Note: When this option is selected, all black in the designated areas will print only with the resin black (K) panel.)</p>

Print All Black With K Panel: _____

Full Card
 Defined Area(s)
 Undefined Area(s)

Print YMC Under K Print K Only

Using the Printer Supplies tab

Use the options on this tab to view information about the Ribbon installed in the Printer.

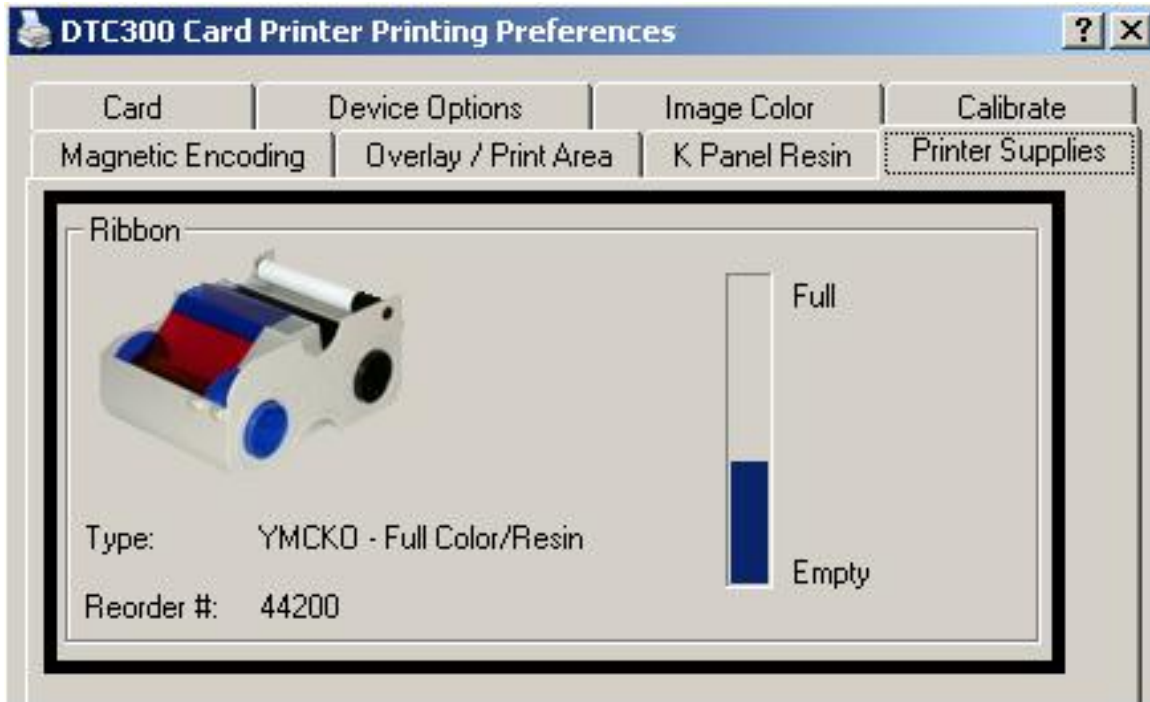

Reviewing the Ribbon Information

Step	Procedure
1	Use the Ribbon information to determine which Ribbon is being used to print with and its part number.

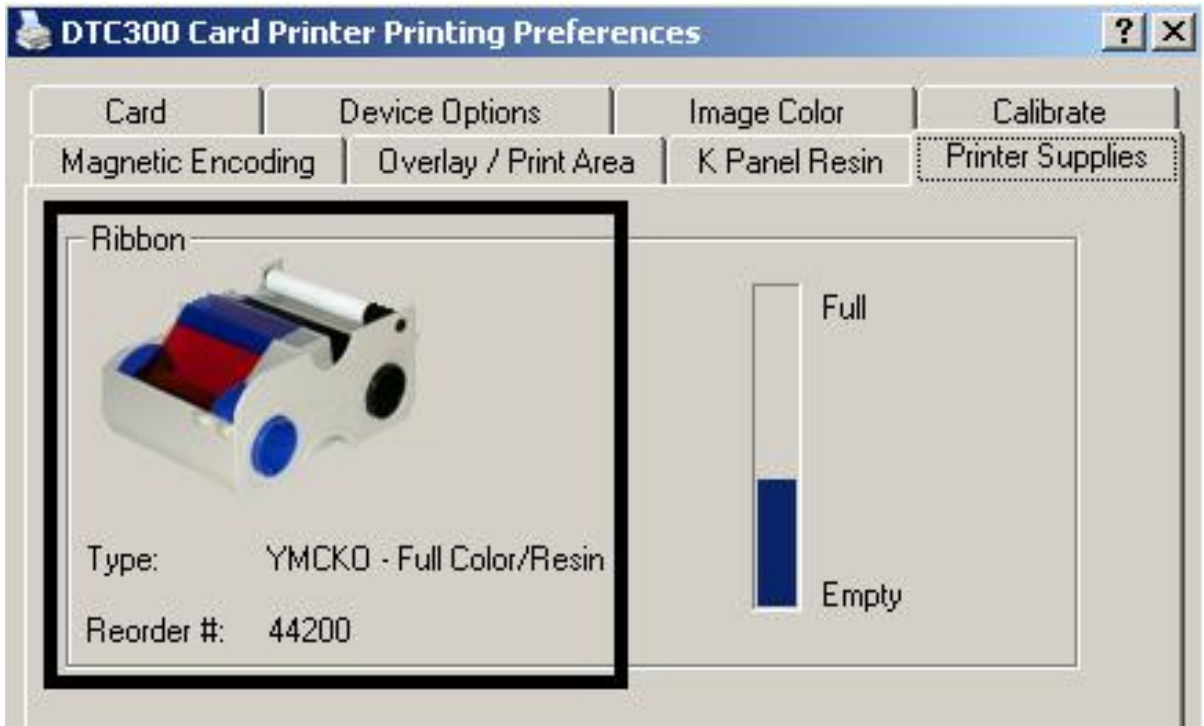

Reviewing the Ribbon Level Indicator

Step	Procedure
1	Use the Ribbon Level indicator to view approximately how much Ribbon is left.

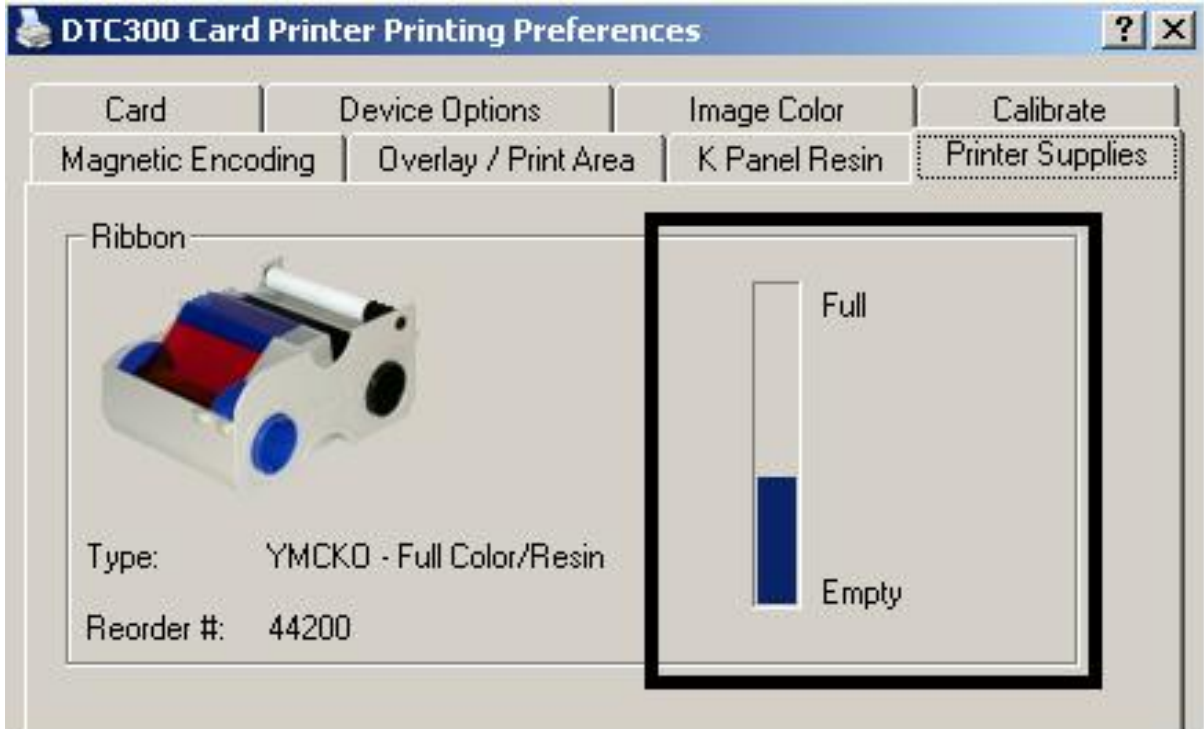

Using the Printer Calibration Utility

Access the Settings dialog box via the **Settings** button on the Calibrate tab. Use the adjustment mode to change the Printer's internal settings. (**Note:** The Card Printer is equipped with an internal adjustment mode programmable through the Settings dialog box. This dialog box is accessible only if the Printer is powered ON, it is in Ready Mode and it is properly connected to the PC.)



Caution! These settings are optimized at the factory. In most cases, these settings can be used without changing them.

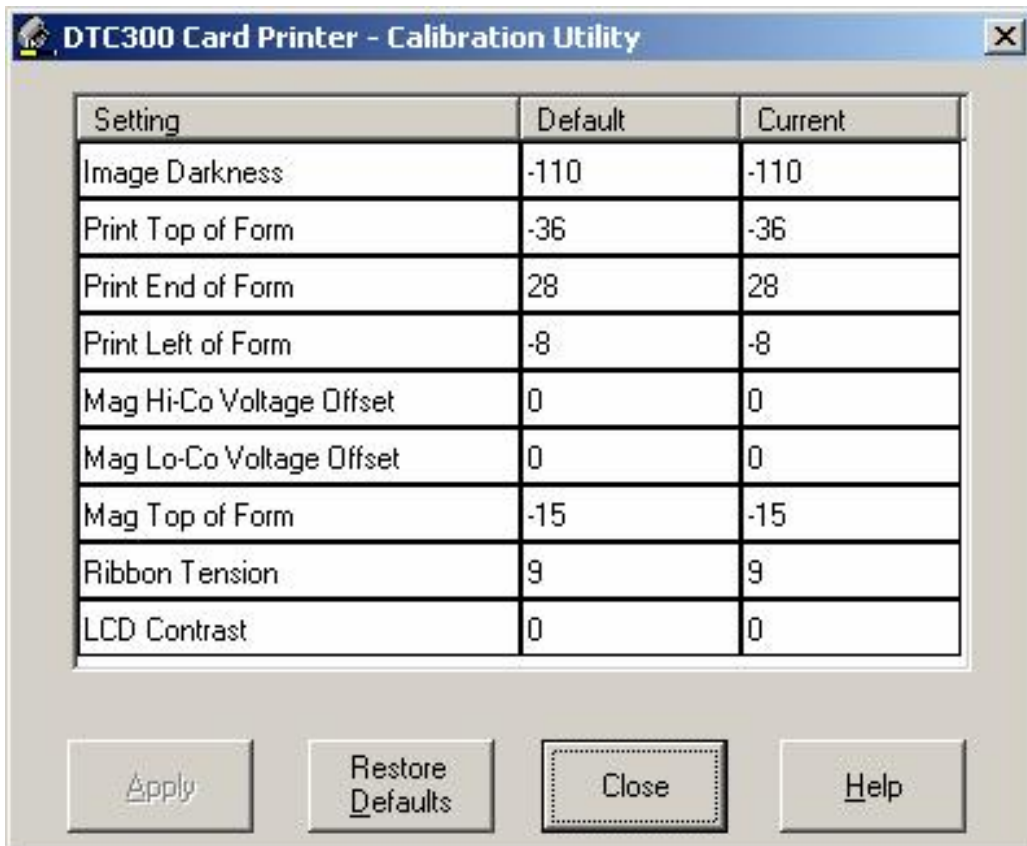

Using the Image Darkness Option

Use this option to set the overall darkness of the printed image by increasing or decreasing the amount of heat used by the Printhead when printing.

Step	Procedure
1	<p>Lighten the printed image by clicking the down arrow ▼ to enter a negative value and decrease the amount of Printhead heat.</p> <p>OR</p> <p>Darken the image by clicking the up arrow ▲ to enter a positive value and increase the amount of Printhead heat.</p> <p> Caution: If the value is set too high, the Ribbon may jam or even break.</p>



Using the Print Top of Form Option

Use this option to adjust the lengthwise or horizontal position of the printed image on a card so it appears centered. (**Note:** When adjusting this value, keep in mind that cards always remain in the same landscape orientation while moving through the Printer.)

The diagram (below) represents how the printed image will move in relation to the fixed card position as a positive or negative Image Placement value is entered.

Step	Procedure
1	<p>Enter a negative value to move the printed image toward the leading edge of the card, or the card output to the side of the Printer.</p> <p>OR</p> <p>Enter a positive value to move the printed image toward the trailing edge of the card, or the card input to the side of the Printer.</p> <ul style="list-style-type: none"> Maximum Adjustment Range: The maximum adjustment range is ± 127. As a rule, 10 equals about .030"/. 8mm, which is about the same as the thickness of a standard CR-80 size card. <p> Caution: If the negative value is set too high, the print Ribbon may break.</p>

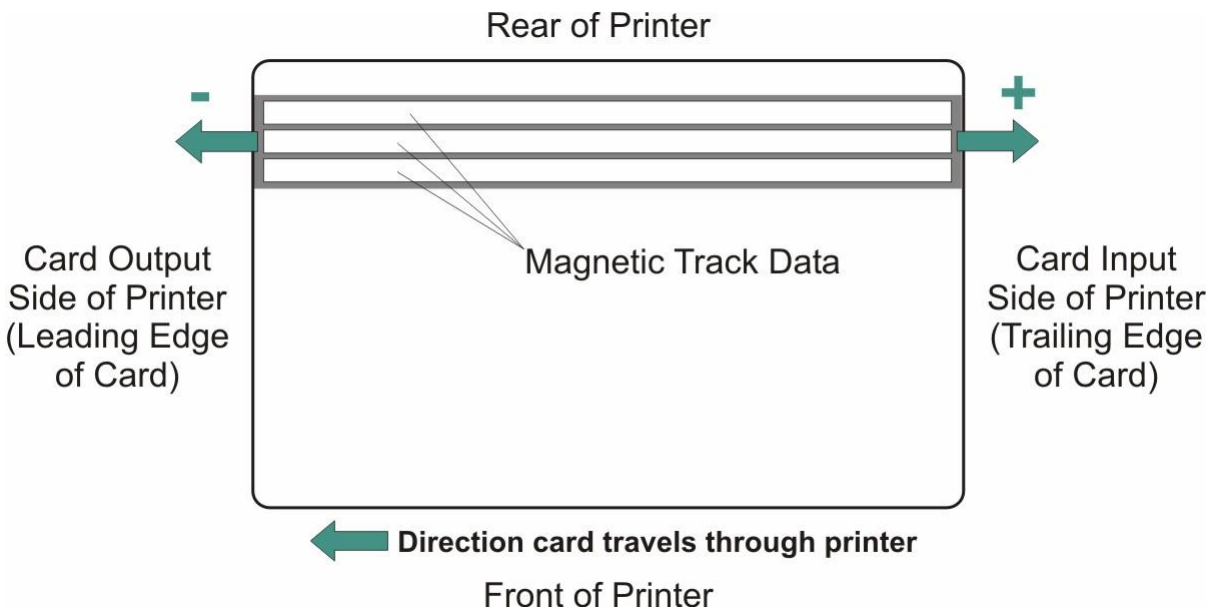

Using the Print End of Form Option

Use this option to reduce or increase the overall printable area in order to optimize edge-to-edge printing toward the trailing edge of a card. (**Note:** When adjusting this value, keep in mind that cards always remain in the same position while moving through the Printer.)

The diagram (below) represents how the end of form will move in relation to the fixed card position as a positive or negative Print End of Form value is entered.

Step	Procedure
1	<p>Enter a negative value to reduce the Print End of Form and move the end of the printable area more toward the leading edge of the card.</p> <p>OR</p> <p>Enter a positive value to increase the print length and move the end of the printable area more toward the trailing edge of the card.</p> <ul style="list-style-type: none"> <p>Maximum Adjustment Range: The maximum adjustment range is ± 127. As a rule, 10 equals about .030"/. 8mm, which is about the same as the thickness of a standard CR-80 size card.)</p>

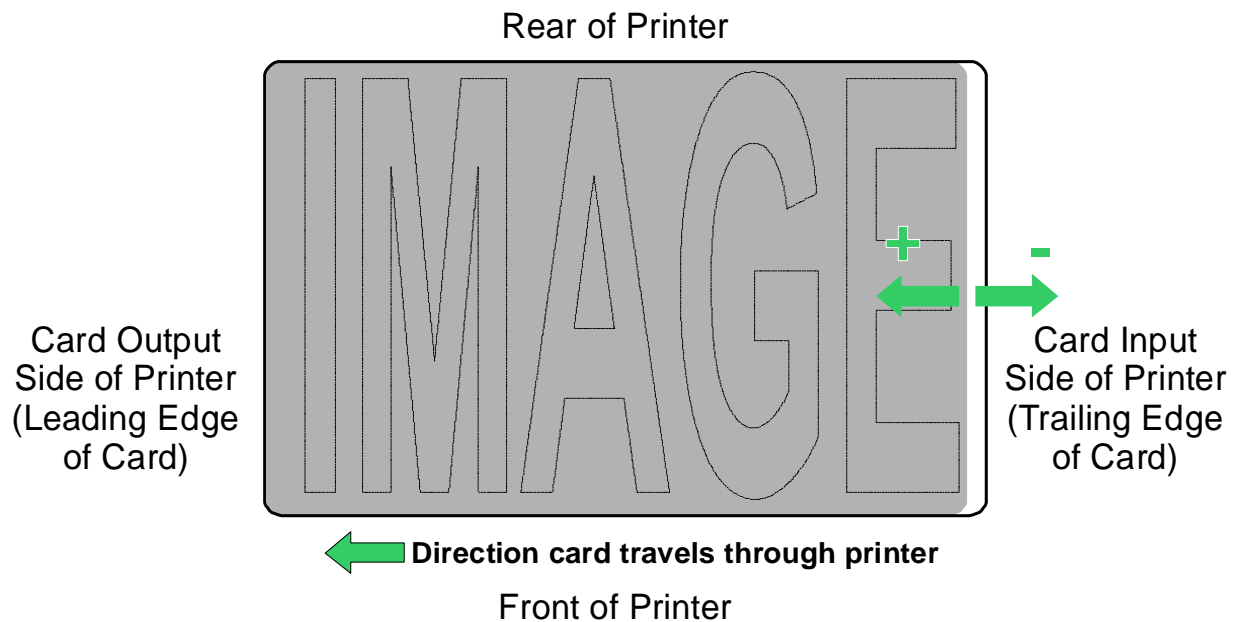

Using the Print Left of Form Option

Use this option to adjust the vertical position of the printed image on a card so it appears centered. (**Note:** When adjusting this value, keep in mind that cards always remain in the same landscape orientation while moving through the Printer.)

Step	Procedure
1	<p>Enter a negative value to move the image towards the bottom edge of the card (See image below),</p> <p>OR</p> <p>Enter a positive value to move the image towards the back top edge of the card (see image below).</p> <ul style="list-style-type: none"> Maximum Adjustment Range: The maximum adjustment range is ± 127. As a rule, 10 equals about .030"/. 8mm. This is about the same as the thickness of a standard CR-80 size card.

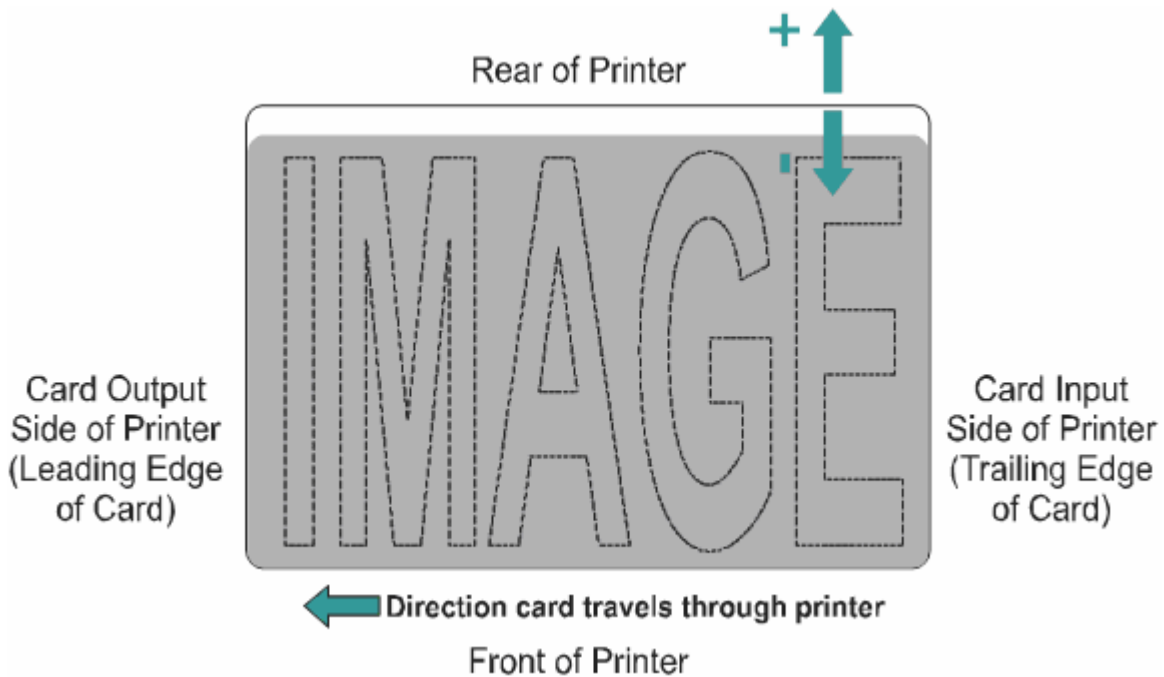

Using the Magnetic Encoder Voltage Offset Option

Use this option to adjust the voltage of the Magnetic Encoder.

- Encoder voltage is set from the factory at a default of 7.24vdc for Hi-Co Magnetic cards and 2.54vdc for Lo-Co Magnetic cards.
- Depending on the cards that are being used, it may be necessary to adjust the encoder voltage out of default.

See the next two procedures for instructions on adjusting the Magnetic Encoder Voltage. (**Note:** The required encoder voltage for the cards will need to be known in order to properly set the Encoder Voltage Offset value. This information should be available through the card manufacturer or reseller).

Adjusting the Hi-Co Voltage Offset

Step	Procedure
1	Identify the Magnetic Encoder voltage required by the cards. (Note: The required encoder voltage for the cards will need to be known in order to properly set the Encoder Voltage Offset value. This information should be available through the card manufacturer or reseller).
2	Use the following equation to identify the proper Mag Hi-Co Voltage Offset value <ul style="list-style-type: none"> $\frac{(((((36500/((\langle \text{Desired Voltage} \rangle + 4.6)/1.23) - 1)) - 2670)/39.0625) - 40) \times -1}{}$ For example: Required Encoder Voltage = 9vdc <ul style="list-style-type: none"> $\frac{(((((36500/((9 + 4.6)/1.23) - 1)) - 2670)/39.0625) - 40) \times -1}{} = 15$
3	Change the Mag Hi-Co Voltage Offset value. I.E 15
4	Use the Diagnostic Utility to run a Magnetic Self test and verify encoded quality.

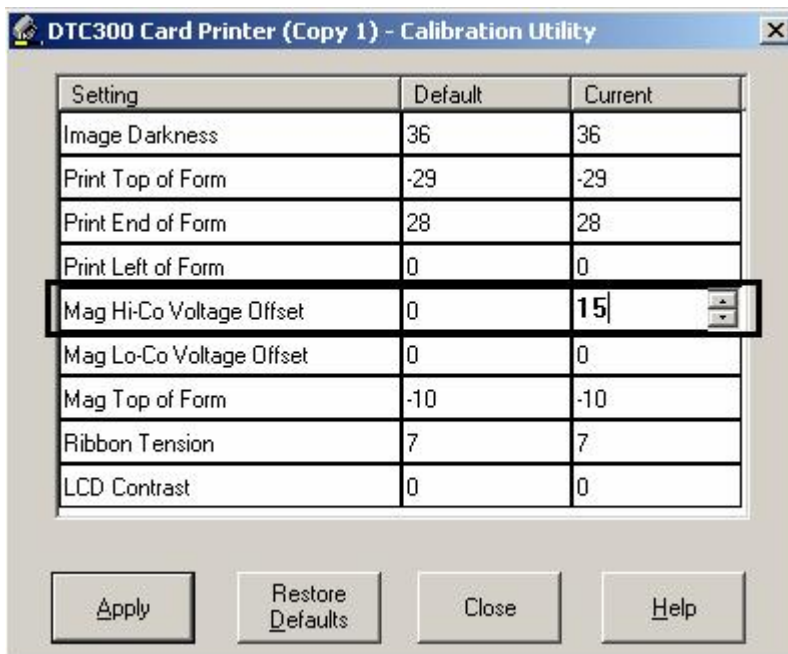

Adjusting the Lo-Co Voltage Offset

Step	Procedure
1	Identify the Magnetic Encoder voltage required by the cards. (Note: The required encoder voltage for the cards will need to be known in order to properly set the Encoder Voltage Offset value. This information should be available through the card manufacturer or reseller).
2	Use the following equation to identify the proper Mag Lo-Co Voltage Offset value <ul style="list-style-type: none"> $(((36500/((\langle\text{Desired Voltage}\rangle+4.6)/1.23)-1))-2670)/39.0625) - 126) \times -1$ For example: Required Encoder Voltage = 1.5vdc <ul style="list-style-type: none"> $(((36500/((1.5+4.6)/1.23)-1))-2670)/39.0625) - 126) \times -1 = -42$
3	Change the Mag Lo-Co Voltage Offset value. I.E -42
4	Use the Diagnostic Utility to run a Magnetic Self test and verify encoded quality.

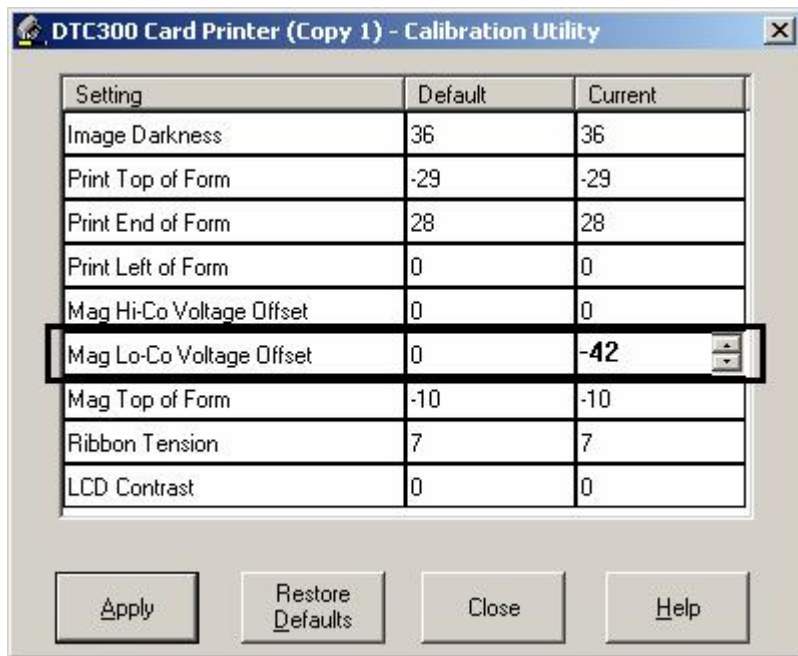

Using the Mag Top of Form Option

Use this option only if the Printer has a built-in Magnetic Stripe encoder. (**Note:** If so, use this option to shift the starting point of where the Printer will begin encoding the magnetic track data on a card's Magnetic Stripe. When adjusting this value, keep in mind that a card and its Magnetic Stripe will always remain in the same relative position as the card travels through the Printer.)

The diagram (below) represents how the magnetic data will move in relation to the fixed position of a card's Magnetic Stripe as a positive or negative Magnetic Offset value is entered. (**Note:** For this diagram, imagine that the card is transparent and the card's Magnetic stripe can be seen through the top or front side of the card.)

Step	Procedure
1	<p>Enter a negative value to move the start of the magnetic data more toward the leading edge of the card, or the card output to the side of the Printer.</p> <p>OR</p> <p>Enter a positive value to move the start of the magnetic data toward the trailing edge of the card, or the card input to the side of the Printer.</p> <ul style="list-style-type: none"> • Magnetic Data Direction: The arrows on these buttons indicate the direction the magnetic data will move on the card's Magnetic Stripe. • Maximum Adjustment Range: The maximum adjustment range is ± 127. As a rule, 10 equals about .030"/. 8mm.) (Note: Keep this in mind when adjusting this option to avoid over-adjusting.) <p> Caution: If the negative value is set too high, the Printer may start encoding before the card's Magnetic Stripe reaches the encoding head.</p>

Using the Mag Top of Form Option (continued)

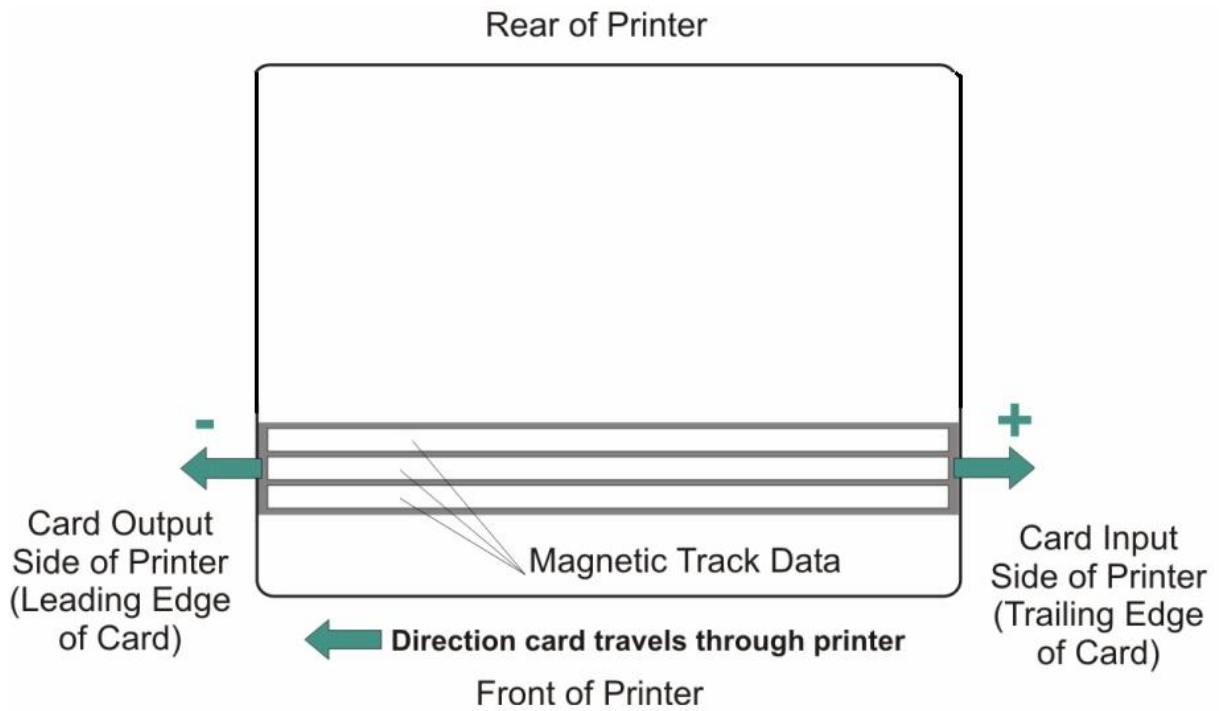

Using the Ribbon Tension Option

Step	Procedure
1	<p>Use the Ribbon Tension option to increase the amount of tension (drag) on the ribbon during printing.</p> <p>Enter a negative value to decrease the amount of tension that is placed on the ribbon during printing</p> <p>OR</p> <p>Enter a positive value to increases the amount of tension that is placed on the ribbon during printing.</p>

Using the LCD Contrast Option



Use this option to adjust the contrast of the LCD.

Step	Procedure
1	<p>Enter a positive value to increase the contrast of the LCD display on the front of the Printer.</p> <p>OR</p> <p>Enter a negative value to decrease the contrast of the LCD display on the front of the Printer.</p>

Section 6: Cleaning

The Card Printer is built to require a minimum amount of maintenance. Nevertheless, there are a few procedures you can perform on a regular basis or as needed to ensure the best possible performance

Safety Messages (review carefully)

Symbol	Critical Instructions for Safety purposes
<p>Danger:</p> 	<p>Failure to follow these installation guidelines can result in death or serious injury.</p> <p>Information that raises potential safety issues is indicated by a warning symbol (as shown to the left).</p> <ul style="list-style-type: none"> • To prevent personal injury, refer to the following safety messages before performing an operation preceded by this symbol. • To prevent personal injury, always remove the power cord prior to performing repair procedures, unless otherwise specified. • To prevent personal injury, make sure only qualified personnel perform these procedures.
<p>Caution:</p> 	<p>This device is electrostatically sensitive. It may be damaged if exposed to static electricity discharges.</p> <p>Information that raises potential electrostatic safety issues is indicated by a warning symbol (as shown to the left).</p> <ul style="list-style-type: none"> • To prevent equipment or media damage, refer to the following safety messages before performing an operation preceded by this symbol. • To prevent equipment or media damage, observe all established Electrostatic Discharge (ESD) procedures while handling cables in or near the Circuit Board and Printhead Assemblies. • To prevent equipment or media damage, always wear an appropriate personal grounding device (e.g., a high quality wrist strap grounded to avoid potential damage). • To prevent equipment or media damage, always remove the Ribbon and Cards from the Printer before making any repairs, unless otherwise specified. • To prevent equipment or media damage, take jewelry off of fingers and hands, as well as thoroughly clean hands to remove oil and debris before working on the Printer.

Using the Required Supplies

For the maintenance procedures outlined for the Printer, you will need a Printer Cleaning Kit, available from the reseller. This kit includes the following:

- Printhead Cleaning Swabs pre-moistened with 99.99% isopropyl alcohol for cleaning the Printer's Printhead.
- Cleaning Cards with an adhesive backing for cleaning the Printer's Card Feed Rollers and Platen Roller.
- Cleaning Pads pre-moistened with 99.99% isopropyl alcohol for cleaning the Printer's general inside and outside area.



Caution: As with any electronic device, internal components of the Printer, such as the Printhead, may be damaged if exposed to static electrical discharges.

- To avoid potential damage, always wear an appropriate personal grounding device, such as a wrist strap (with integral resistor) connected to an ESD ground.

Cleaning Procedures

Cleaning the Printhead

Perform this procedure during every **1000 prints** to maintain consistent print quality. Also, perform this procedure after noticing a streak on the card where color was not transferred.



Warning: Never use a sharp tool or abrasive object of any kind to clean the Printhead, which can damage it.

Step	Procedure
1	Open the Printer's Front Cover.
2	Remove print ribbon
3	Use a Printhead Cleaning Swab from the Printer Cleaning Kit (P/N 085976) to gently rub back and forth over the entire length of the printhead 3 to 4 times
4	<p>Once the Printhead is completely dry, replace the ribbon cartridge and close the Printer.</p>  <p>Caution: If a streak persists, use an Acetone compound to clean the Printhead.</p>

Cleaning the Card Feed and Cleaning Rollers

The Card Feed Rollers move the card throughout the print process. The Cleaning Roller removes dust particles from a blank card as it feeds into the Printer. Cleaning these Rollers will help prevent card jams and card contamination and will ultimately lead to better print quality and extended Printhead life.

Step	Procedure
1	<p>Ensure a consistent Printer operation by cleaning these Rollers approximately every 1000 prints, depending on the cleanliness of the card stock and the environment (in which the Printer is located).</p> <p>Clean the Rollers if the Rollers appear dirty or if the cards start showing speckles or debris on the printed surface by following Steps 2 to 7 (below).</p>
2	Leave the Printer power ON and open the Printer's Front Cover.
3	Remove all cards from the Printer's Card Input Hopper.
4	Get a Cleaning Card from the Printer Cleaning Kit and remove its adhesive backing paper from both sides.
5	Insert the Cleaning Card into the card exception Single Feed Slot until the card stops.
6	<ol style="list-style-type: none"> a. Open the Printer Control Panel from the Computer. <ul style="list-style-type: none"> • If using Windows 98SE/Me, right click on the DTC300/DTC300M Card Printer Icon and select Properties. • If using Windows 2000/XP, right click on the DTC300/DTC300M Card Printer and select Printing Preferences. Click on the Calibrate tab. b. Click on the Clean Printer button. (See below.) c. Remove the Ribbon and close the front cover. d. Click on the Clean button.

Cleaning the Printer's Exterior

The Printer has a durable casing that should retain its luster and appearance for many years. Clean it only with a **Cleaning Pad** from the Printer Cleaning Kit.



Caution: Do not use cleaning solvents of any kind or spray the Printer's exterior with a cleaner!

Cleaning the Printer's Interior

Dust and other particles may accumulate inside the Printer with continued usage. These particles are attracted to the print Ribbon or blank card by static produced during printing and can contaminate the printed card causing spots or speckles to appear. Periodically, use the following procedure to remove dust and other contaminants:

Step	Procedure
1	Open the Printer's Front Cover.
2	Remove the Ribbon Cartridge from the Printer.
3	Use a Cleaning Pad from the Printer Cleaning Kit to wipe out all visible areas inside the Printer. Remove any debris that may be inside. Be extremely careful not to let any alcohol drip inside the Printer!
4	Re-install the printing supplies and close the Printer.

Section 7: Packing the Card Printer

The purpose of this section to provide the User with a specific packing procedure for this Card Printer.



Follow this instruction to pack the Card Printer for transport.

Step	Procedure
1	Clean the inside of the Printer with compressed air.
2	Wipe it down with a lint-free cloth.
3	Clean the Printhead with a alcohol swab.
4	Pack the Printer in the original carton and packing materials.
5	Ensure to enclose any necessary paperwork, test cards, etc.

Section 8: Board Level Diagnostics

The purpose of this section to provide the User with specific Board Level Diagnostic procedures for Board Errors and Sensor Testing for this Card Printer.

Safety Messages (review carefully)

Symbol	Critical Instructions for Safety purposes
<p>Danger:</p> 	<p>Failure to follow these installation guidelines can result in death or serious injury.</p> <p>Information that raises potential safety issues is indicated by a warning symbol (as shown to the left).</p> <ul style="list-style-type: none"> • To prevent personal injury, refer to the following safety messages before performing an operation preceded by this symbol. • To prevent personal injury, always remove the power cord prior to performing repair procedures, unless otherwise specified. • To prevent personal injury, make sure only qualified personnel perform these procedures.
<p>Caution:</p> 	<p>This device is electrostatically sensitive. It may be damaged if exposed to static electricity discharges.</p> <p>Information that raises potential electrostatic safety issues is indicated by a warning symbol (as shown to the left).</p> <ul style="list-style-type: none"> • To prevent equipment or media damage, refer to the following safety messages before performing an operation preceded by this symbol. • To prevent equipment or media damage, observe all established Electrostatic Discharge (ESD) procedures while handling cables in or near the Circuit Board and Printhead Assemblies. • To prevent equipment or media damage, always wear an appropriate personal grounding device (e.g., a high quality wrist strap grounded to avoid potential damage). • To prevent equipment or media damage, always remove the Ribbon and Cards from the Printer before making any repairs, unless otherwise specified. • To prevent equipment or media damage, take jewelry off of fingers and hands, as well as thoroughly clean hands to remove oil and debris before working on the Printer.

Sensor and Motor

Reviewing the Sensor Location and Voltages

Use this table as a reference tool for Board Level Diagnostics

Sensor	Location	Pin	Low Range VDC	High Range VDC
RFID Board	J5	3	Present .02	Not Present .70
Headlift	J9	1, 3 (+, -)	Not Depressed 0 - .17	Depressed 4.9 – 5.5
Print Cover Sensor (Sensor mounted to Main Board)	J4	1, 2 (+, -)	Not Depressed 0 - .17	Depressed 4.9 – 5.5
Print Ribbon Encoder Sensor	J4	3,4 (+, -)	Unblocked 0 -.17	Blocked 4.9 – 5.5
Card Detection Sensor	J4		Unblocked 0 -.17	Blocked 4.9 – 5.5

Reviewing the Motor Voltages (when active)

Use this table as a reference tool for Board Level Diagnostics

Motor	Location	Pin	VDC
Print Drive Stepper	J3	4	4
Print Headlift	J20	6	17.0
Ribbon Drive	J20	8	5

Section 9: Menu Option Tree

Accessing the Menu Option Structure Tree

When the Printer is powered on and sitting idle, a **MENU** option appears above the center softkey button. Use this menu option to access the functions, as shown below. Refer to the Menu Option Structure Tree for all available menu options.

Selecting from the Menu Option Structure Tree (displayed, below)

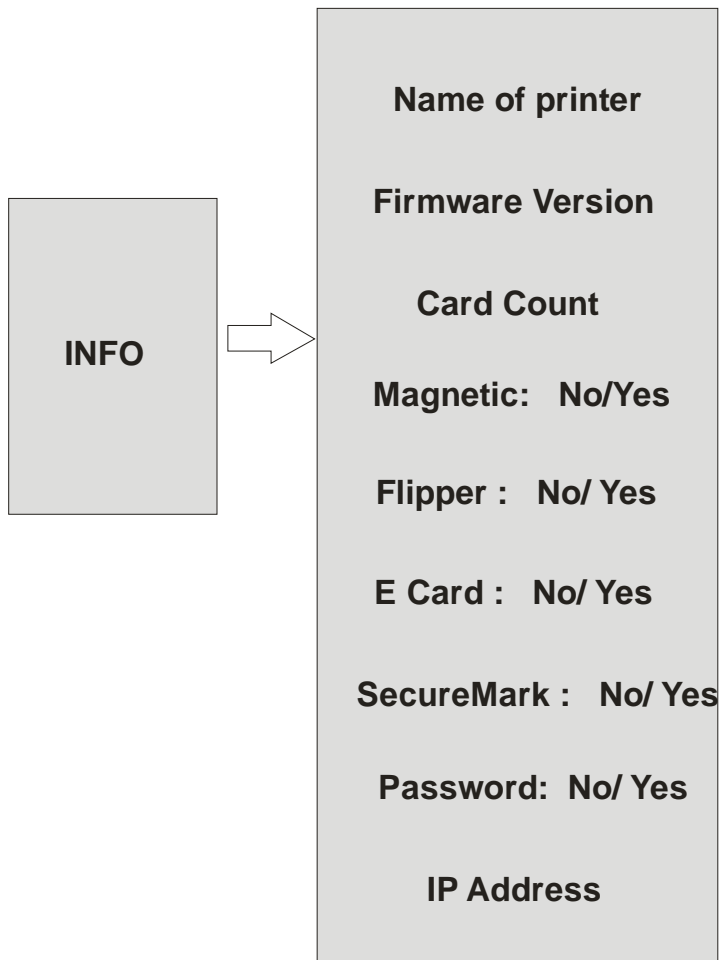

Section 10: Firmware Upgrades



Introduction

The DTC300/DTC300M Card Printer/Encoder - Firmware Upgrade Document (Rev. 1.3) and this section are identical. They both provide step-by-step procedures for upgrading the Firmware on these Printers.

Requirements

- Windows 32 bit Operating System (XP/2000)
- Internet Access

Safety Messages (review carefully)

Symbol	Critical Procedures for Safety purposes
<p>Danger:</p> 	<p>Failure to follow these installation guidelines can result in death or serious injury.</p> <p>Information that raises potential safety issues is indicated by a warning symbol (as shown to the below).</p> <ul style="list-style-type: none"> • To prevent personal injury, refer to the following safety messages before performing an operation preceded by this symbol. • To prevent personal injury, always remove the power cord prior to performing repair procedures, unless otherwise specified. • To prevent personal injury, make sure only qualified personnel perform these procedures.
<p>Caution:</p> 	<p>This device is electrostatically sensitive. It may be damaged if exposed to static electricity discharges.</p> <p>Information that raises potential electrostatic safety issues is indicated by a warning symbol (as shown to the below).</p> <ul style="list-style-type: none"> • To prevent equipment or media damage, refer to the following safety messages before performing an operation preceded by this symbol. • To prevent equipment or media damage, observe all established Electrostatic Discharge (ESD) procedures while handling cables in or near the Circuit Board and Printhead Assemblies. • To prevent equipment or media damage, always wear an appropriate personal grounding device (e.g., a high quality wrist strap grounded to avoid potential damage). • To prevent equipment or media damage, always remove the Ribbon and Cards from the Printer before making any repairs, unless otherwise specified. • To prevent equipment or media damage, take jewelry off of fingers and hands, as well as thoroughly clean hands to remove oil and debris before working on the Printer.

Downloading Firmware

Step	Procedure
1	<p>Open the Fargo Diagnostic Utility (located in the Programs folder), as shown below.</p> <ul style="list-style-type: none"> • Click on the Start icon on the desktop. • Select the Programs folder. • Select the Fargo folder. • Click on the Diagnostic Utility, as shown below.

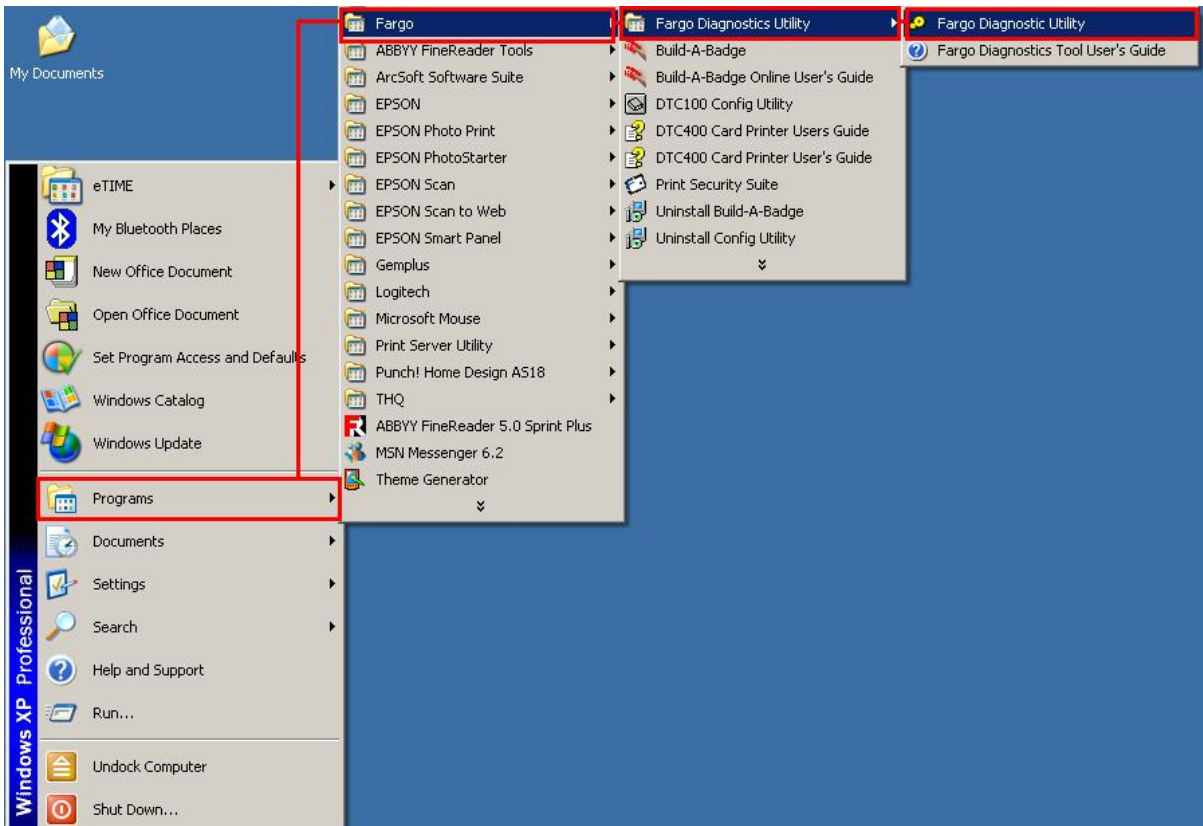

Downloading Firmware (continued)

Step	Procedure
2	Use the Select a printer to continue dropdown menu to select the Printer. a. Click on the Download Firmware button under Step 1: , as shown below.

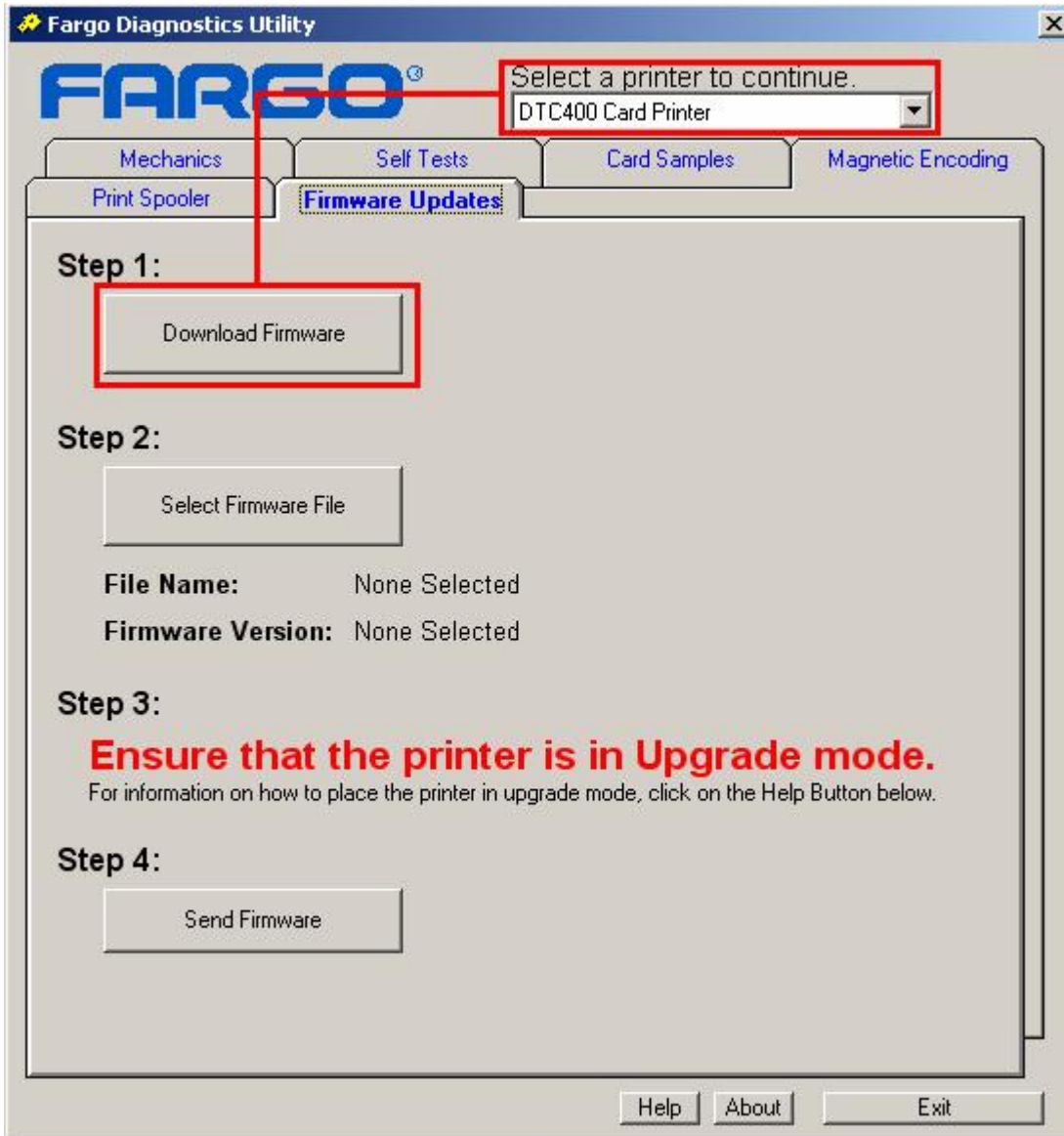

Downloading Firmware (continued)

Step	Procedure
3	a. Check that the Computer has an active internet connection. b. Click on the Yes button, as shown below.



Downloading Firmware (continued)

Step	Procedure
4	This will launch the Fargo Support page <ul style="list-style-type: none"> • Click on the Firmware selection box. • Using the drop down menu select the Printer. • Click on the Go button, as shown below.

The screenshot shows the Fargo Tech Support website. At the top, the address bar displays 'http://www.fargosupport.com/'. The Fargo logo is on the left, and 'FARGO Web Sites: Fargo.com' is on the right. Below the logo is a navigation menu with links: Drivers, Firmware & User's Guides, Troubleshooting, Software, Archive, Register, Warranties, Service Providers, and Contact Us. The main content area is titled 'Tech Support: Home' and contains a welcome message. Below this is a 'Tech Support: Search' section with the question 'What do you need?'. There are four checkboxes: 'Driver' (unchecked), 'User's Guides' (unchecked), 'Firmware' (checked), and 'All' (unchecked). A red box highlights the 'Firmware' checkbox. Below this is the question 'For what product?' with a dropdown menu showing 'DTC400' and a 'Go' button. A red box highlights the 'Go' button. To the right of the search section is a 'LOCATE AN AUTHORIZED SERVICE PROVIDER' section with a map of the United States and a 'FARGO' logo. At the bottom of the page is a footer with links: Home, Drivers, Firmware & User's Guides, Troubleshooting, Archive, Register Printer, Warranties, Service Providers, Contact Us, Privacy Policy, Terms of Use, © 2003 FARGO Electronics, Inc. All Rights Reserved, FARGO.COM, and PARTNER SERVICES.

Downloading Firmware (continued)

Step	Procedure
5	Click on the Printer name under Printer Firmware to begin the download, as shown below.

Printer Firmware	Version #	Date of Release	File Size (bytes)
DTC400 Firmware	V1.1.1	10/21/2004	124 KB

Downloading Firmware (continued)

Step	Procedure
6	Click on the Save button to save the file, as shown below.



Downloading Firmware (continued)

Step	Procedure
7	Click on the Save button to save the file to the computer's Desktop, as shown below.

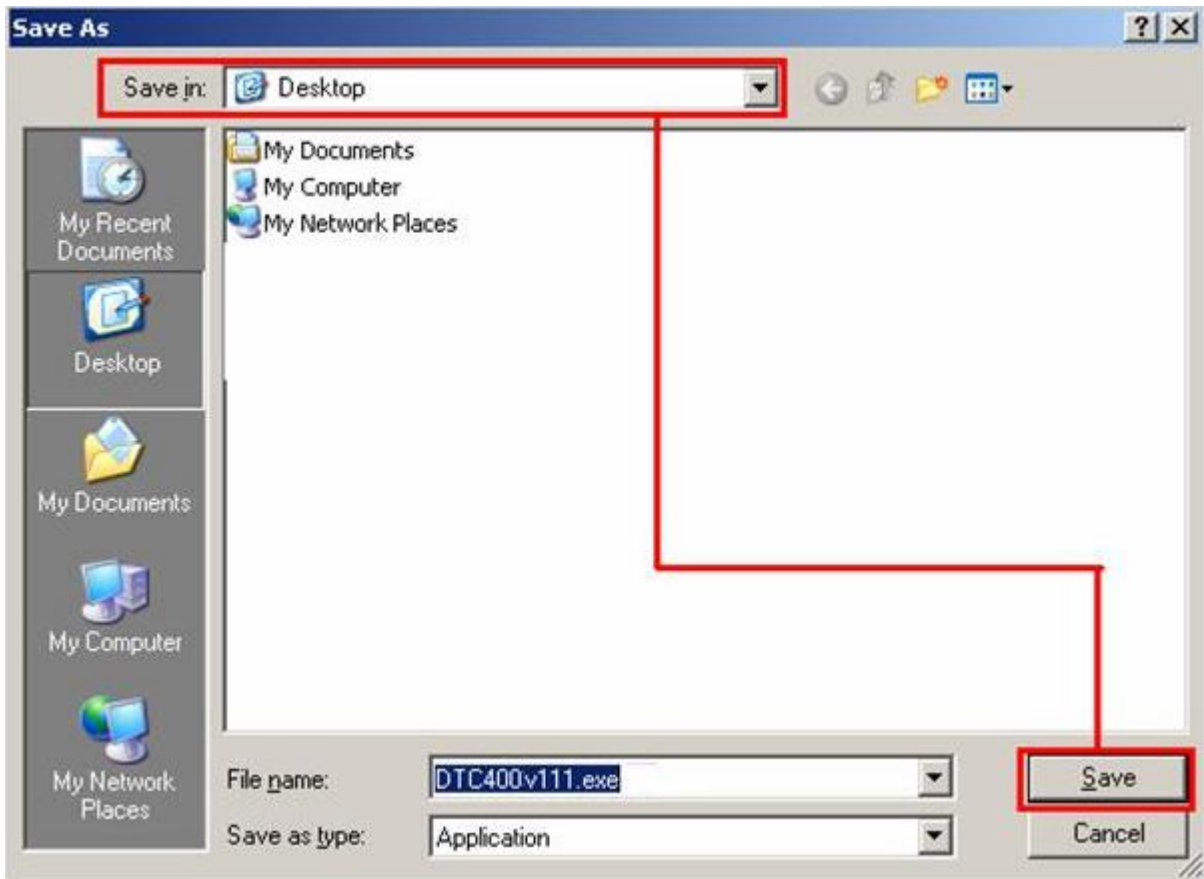

Downloading Firmware (continued)

Step	Procedure
8	Click on the Close button to close this dialog when the download is completed, as shown below.

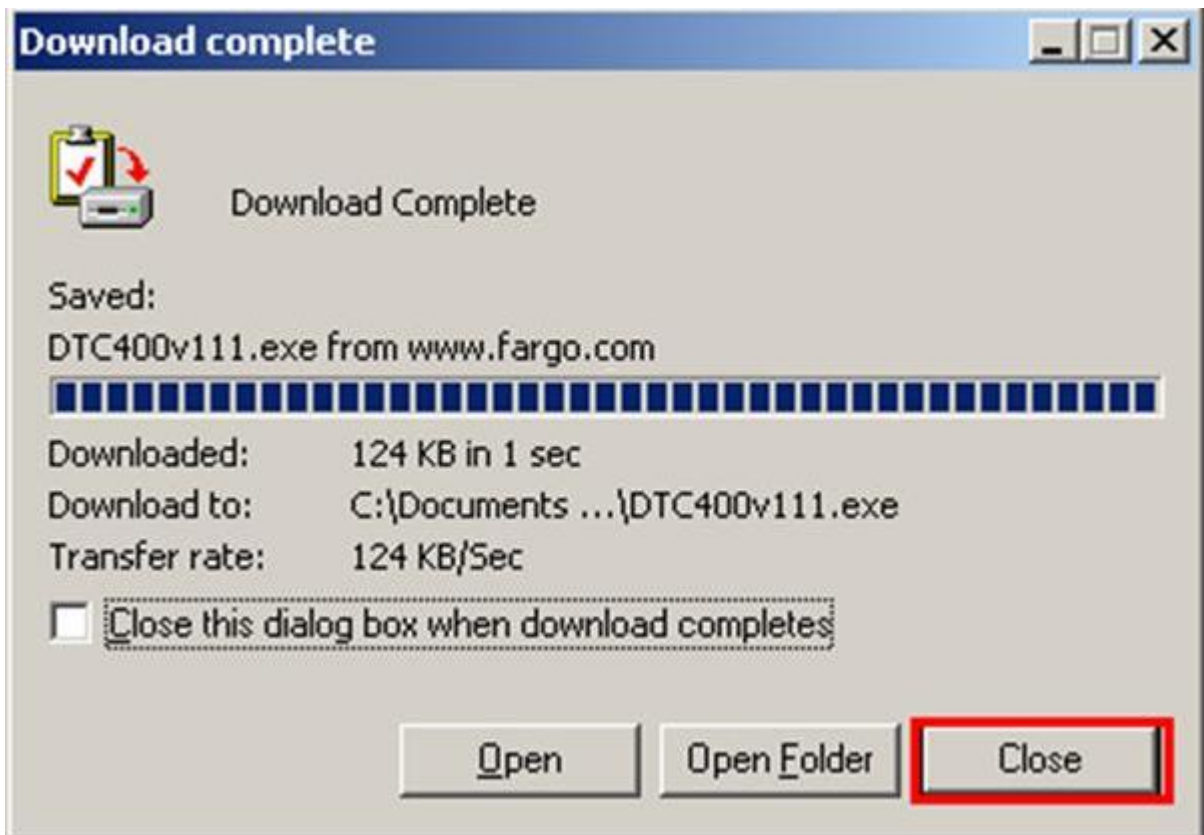

Downloading Firmware (continued)

Step	Procedure
9	From the computer's desktop, double click on the Firmware .exe file to un-zip it, as shown below.

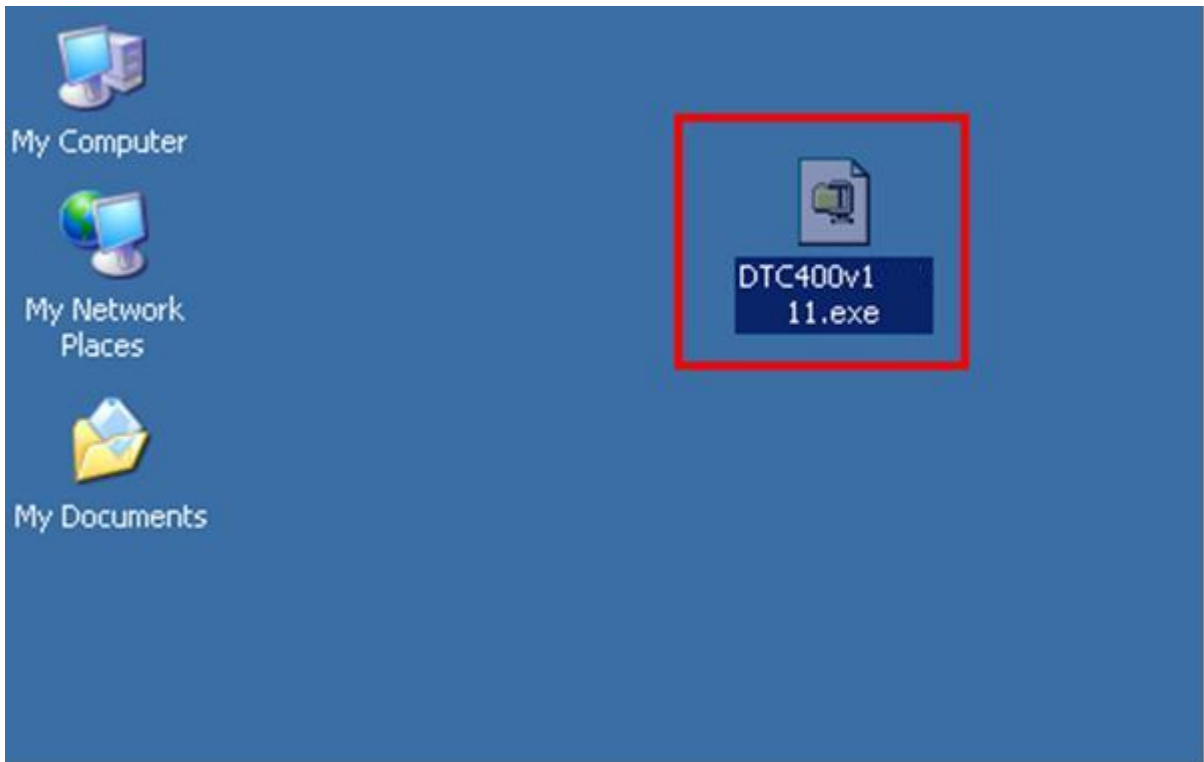

Downloading Firmware (continued)

Step	Procedure
10	Click on the Browse button on the WinZip Self-Extractor window, as shown below.

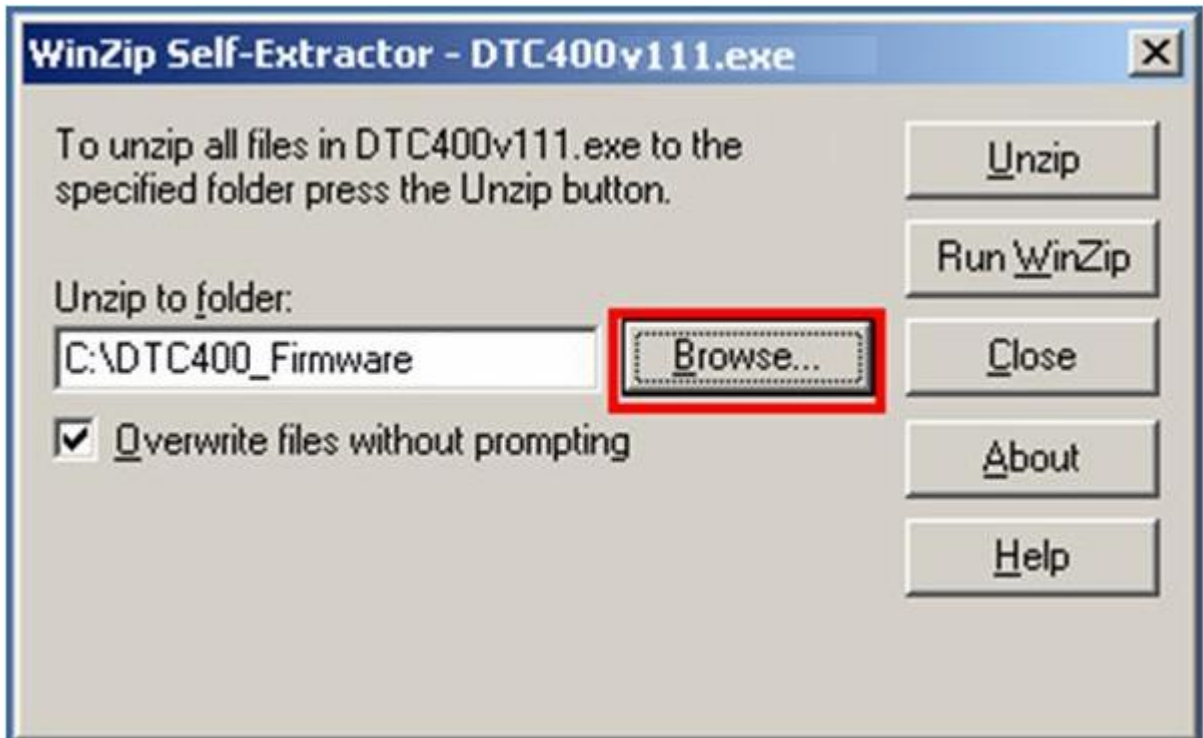

Downloading Firmware (continued)

Step	Procedure
11	Select the Desktop, then click on the OK button in the Browse for Folder dialog, as shown below.

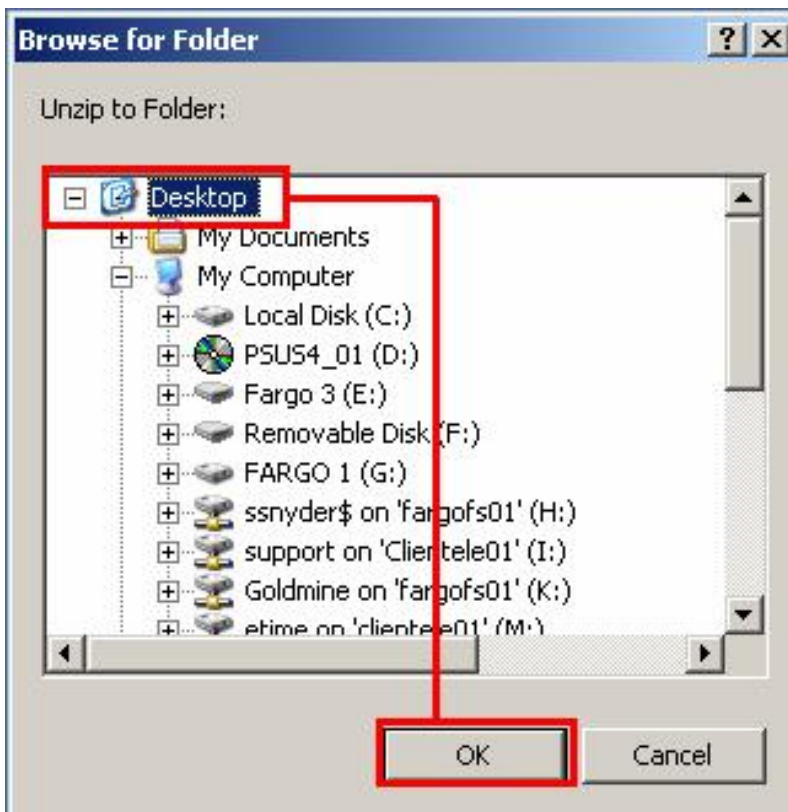

Downloading Firmware (continued)

Step	Procedure
12	Click on the Unzip button in the WinZip Self-Extractor window to unzip designated files, as shown below



Downloading Firmware (continued)

Step	Procedure
13	Click on the Select Firmware File button under Step 2: in the Fargo Diagnostic Utility window, as shown below.

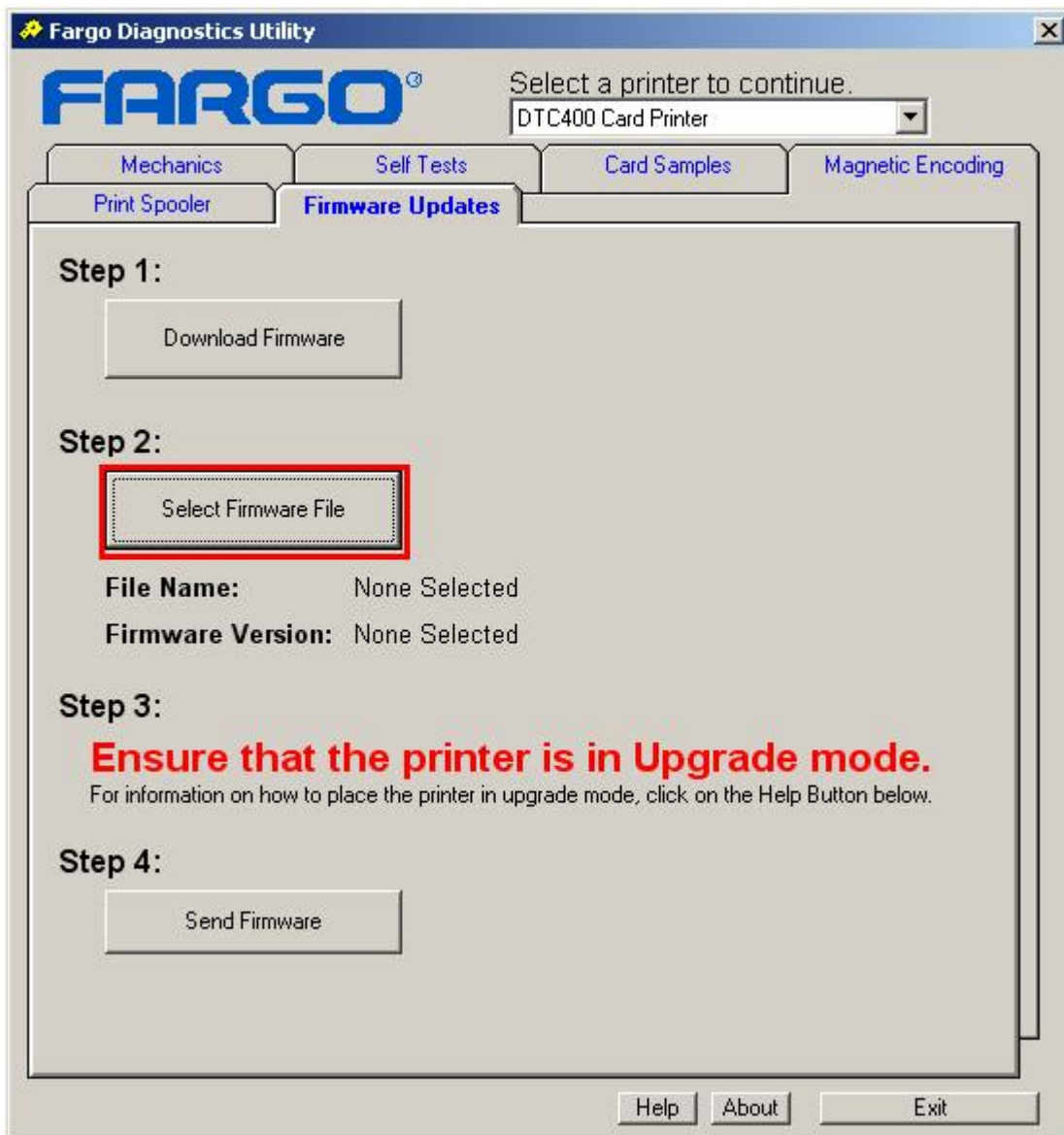

Downloading Firmware (continued)

Step	Procedure
14	<ul style="list-style-type: none"> • Select the Desktop dropdown menu. • Click on the .frm file. • Click on the Open button, as shown below.
15	This completes the Downloading Firmware procedure.

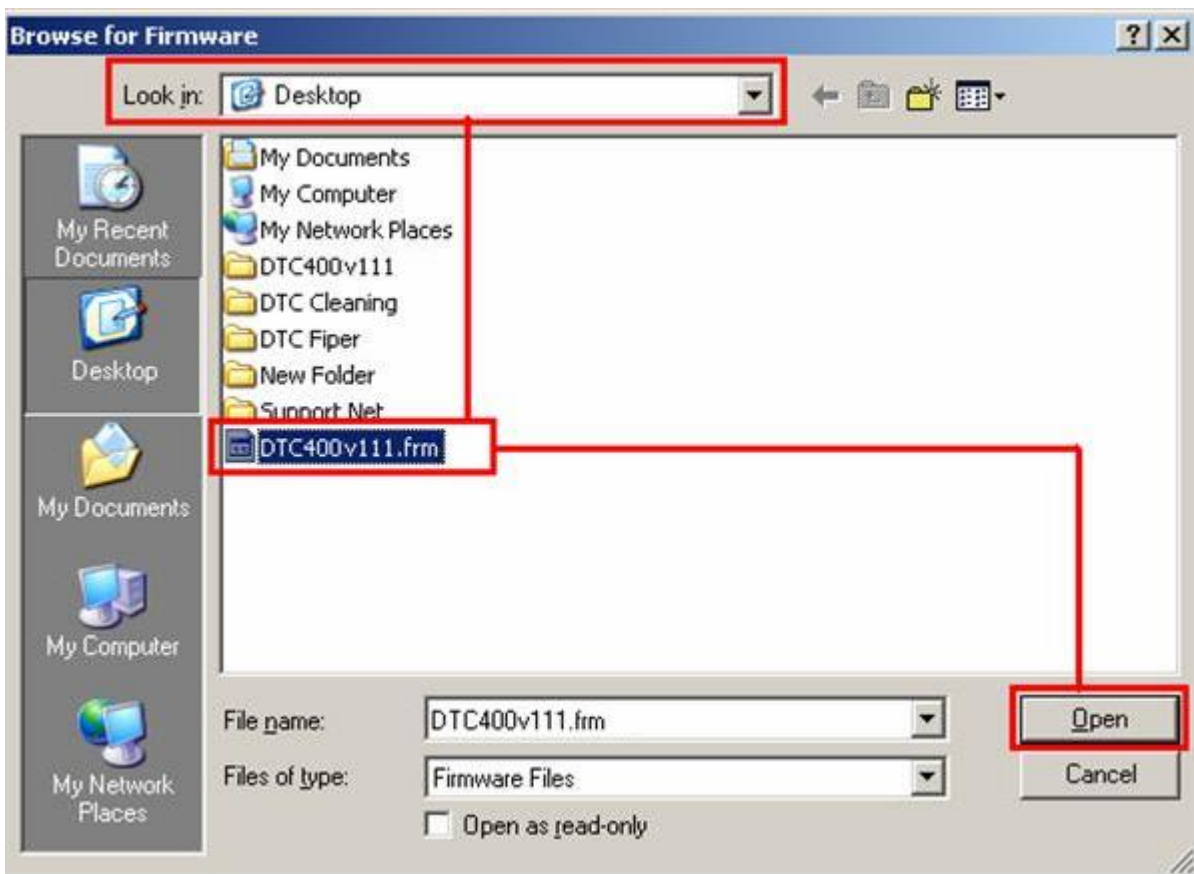

Placing the Printer in the Firmware Upgrade Mode

Step	Procedure
1	 Caution: Turn off the Printer and unplug the power cord from the Printer.
2	Press and hold down the Power and Pause buttons on the Printer, as shown below.
3	Continue to hold down both the Power and Pause buttons as the power is reapplied, hold the buttons down for two (2) seconds after the power has been restored and then release. (Note: The LCD display should now show the Upgrade Firmware message, as shown below).
4	Press the Yes button on the LCD to continue with the Firmware Upgrade.

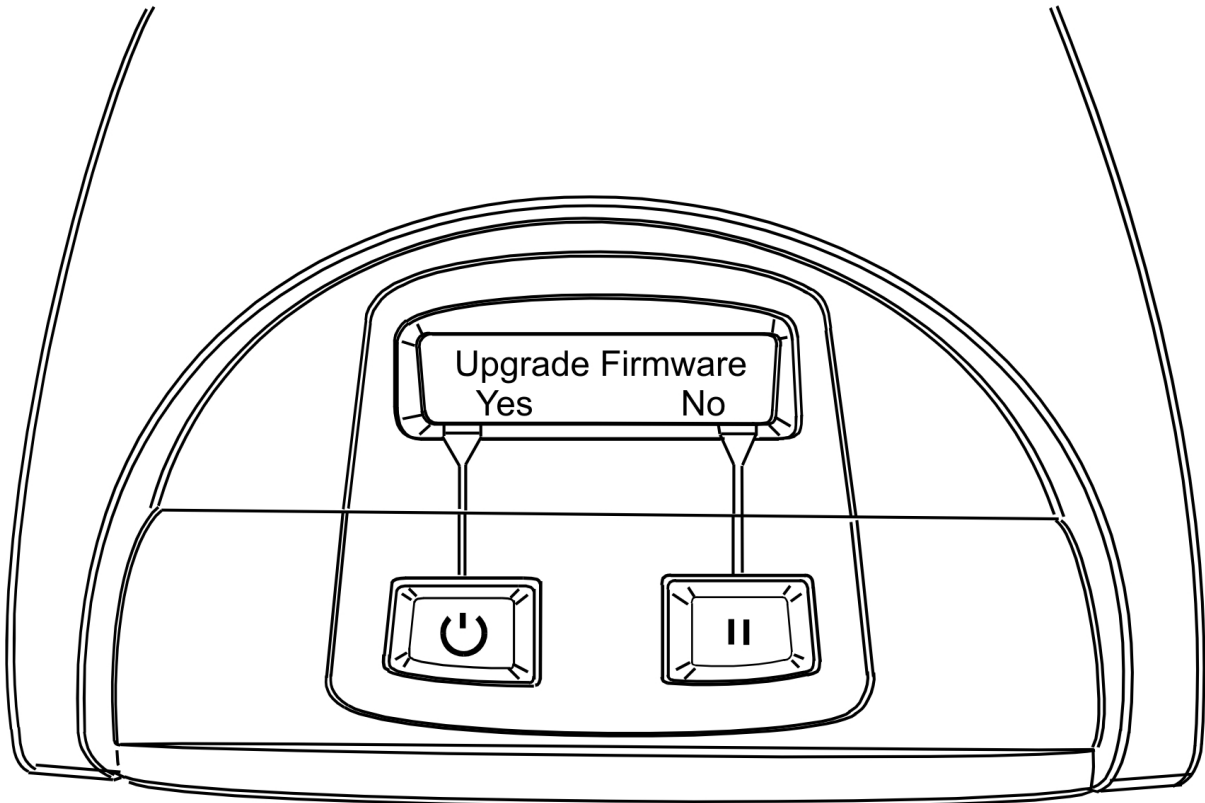

Placing the Printer in the Firmware Upgrade Mode (continued)

Step	Procedure
2	Ensure that the Printer LCD displays this message: as shown below Upgrade Firmware Send File Now.

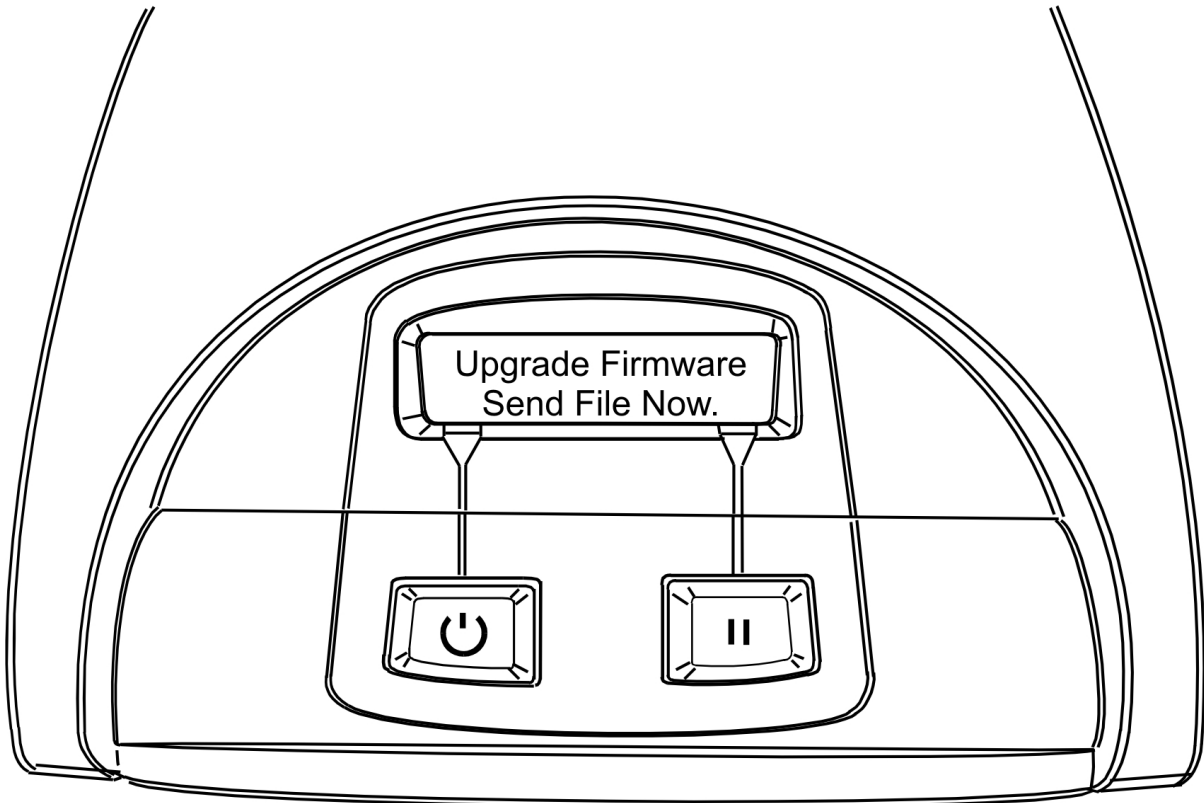

Sending the Firmware File

Step	Procedure
1	Ensure that the Printer LCD displays this message: Upgrade Firmware Send File Now
2	From the Fargo Diagnostic Tool click on the Send Firmware button, as shown below.

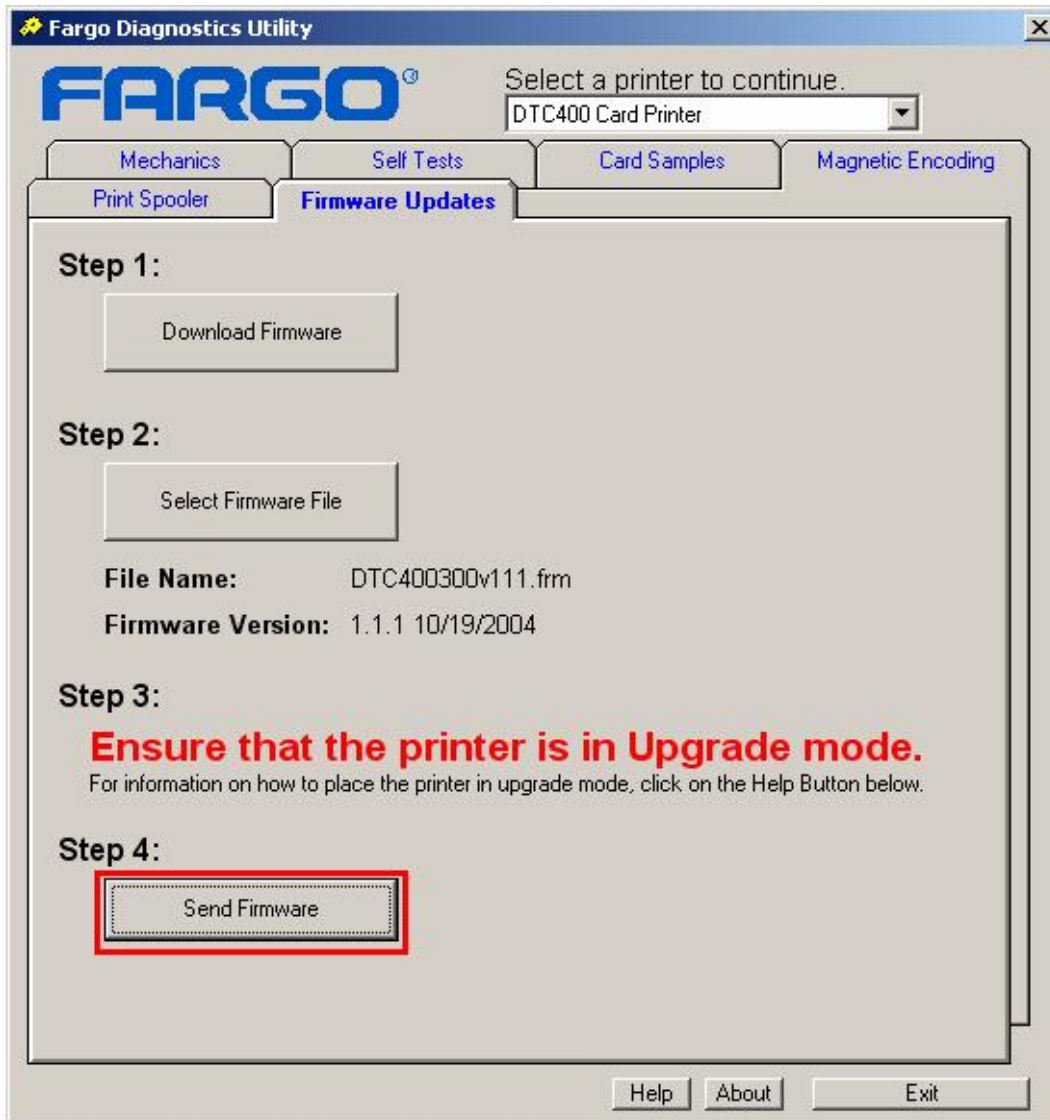

Sending the Firmware File (continued)

Step	Procedure
3	Upon successful completion of the Firmware Update, the Printer will restart.
4	The procedure is now completed.

Section 11: Fargo Technical Support

The purpose of this section to provide the User with an efficient, step-by-step procedure to be used when contacting Fargo Technical Support as needed for this Card Printer.

Contacting Fargo Technical Support

Step	Procedure
1	<p>Refer to Section 3: General Troubleshooting as needed.</p> <p>Contact the Fargo Technical Support Group by phone at (952) 941-0050 or by fax at (952) 941-1852 for additional technical assistance.</p> <p>OR</p> <p>Contact Fargo Technical Support via the Web: http://www.fargosupport.com</p>
2	<p>Position a phone near the Printer and Computer so Fargo technicians can help to help troubleshoot the Printer(s).</p>
3	<p>Please have a self-test and a sample card ready when calling Fargo Technical Support.</p>

Reading the Serial Numbers on a Fargo Printer

The purpose of this section is to provide updated instructions for reading serial numbers on a Fargo Printer.

Finding out when a Fargo Card Printer was manufactured

You can determine when your card Printer was manufactured by reading directly from the serial number (affixed to your card Printer).

1. **Year Built:** The first two digits in the serial number indicate the year that the Printer was manufactured.
2. **Week Built:** The second two digits indicate the week.
3. **Numeric Order:** The last four digits indicate the sequence number for the numeric order in which the Printers were built.

Reviewing Example No. 1: Serial Number 80453289

1. **80453289:** The first two digits in the serial number indicate the year the Printer was built (e.g., the digits 80 indicate the year 1998).
2. **80453289:** The third and fourth digits in the serial number indicate the week the Printer was built (e.g., the digits 45 indicate week 45 of that year).
3. **80453289:** The last four digits indicate the sequence number for the numeric order in which the Printers were built.

Reviewing Example No. 2: Serial Number A1280224

1. **A1280224:** The first two digits in the serial number indicate the year the Printer was built (e.g., the letter and digit A1 indicate the year 2001).
2. **A1280224:** The third and fourth digits in the serial number indicate the week the Printer was built (e.g., the digits 28 indicate week 28 of that year).
3. **A1280224:** The last four digits indicate the sequence number for the numeric order in which the Printers were built.

Section 12: Reviewing the Spare Parts List

Reviewing the DTC300/DTC300M Spare Parts List

DTC300/DTC300M ID Card Printer

Recommended Spare Parts List

Effective Date: As shown with list

For current pricing see http://www.fargopartner.com/support_services/

Section 13: Glossary of Terms

Term	Definition
24-bit color	A color depth for an image that uses 8 bits for each color (red, blue, green) combining the possible 256 shades to provide a color depth of 16.7 million colors.
AC - Alternating Current	An electrical current that reverses its direction at regular intervals (typically 50 - 60 times a second).
Access Card	The card for the SmartGuard security system. A card with embedded electronics that can be removed from the Printer, locking the Printer and preventing unauthorized use.
Adhesion	The firm attachment of a material to the card surface, confirmed by using the Tape Test -pulling an applied piece of adhesive tape (Scotch 600 or equivalent) off the card at 1 sec/in to see if any material is pulled off by the tape.
Algebraic	A type of color matching that takes the color value of pixels and applies them to an algebraic equation to adjust the levels of hue, saturation and brightness.
ANSI (American National Standards Institute)	The United States Representative to ISO, providing standardization for U.S. Manufacturers prior, or in addition, to acceptance by ISO.
AS400	An IBM operating system running on a main frame. DTC500 Fargo Printers are built with fonts saved in the Printer memory so users of AS400 can write escape codes and print from the Printer.
ASCII (American Standard Code for Information Interchange)	A standard for processing information in computer processors. An 8-bit character set of 255 decimal numbers, each assigned to numbers, letters, punctuation and special characters.
AT	Refers to an IBM standard in early computing with regard to the chipset and function of the parallel port, set up in the BIOS.
B (Black)	Black Dye-Sublimation panels are distinguished from the black panel using resin by the use of B for dye sub black. K denotes resin black.

Continued on the next page

Glossary of Terms (continued)

Term	Definition
Barcodes	A series of alternating black and white stripes, of varying widths (each character denoted by a set number and width of black stripes) that allows characters to be optically read by a computer.
Batch print	A file sent down from the computer that contains commands to print a number of cards, sequentially.
Battery Back-up	A power supply that can keep AC electronic equipment running for a short time when power is interrupted, allowing enough time for the user to save data and close the machine properly.
Bi-directional	A communication standard that allows two way data transfer between PC and Printer.
BIOS (Basic Input/Output System)	The part of the operating system in a computer that handles communication between the PC mainboard and its peripherals. Typically residing in chip-based, non-volatile memory.
Bit	An abbreviation for binary digital. Each bit is an element of information that can have two states: off and on.
Bit map	A graphic produced by an array of pixel elements with the color hue, brightness and saturation information stored in bits. The more bits, the more values and thus the greater variety. 1 bit color is black and white, 8-bit color produces 256 shades of gray and 24-bit color can produce 16.7 million colors.
Board	A term used for the circuit board, a hard mylar plate made of many layers, that holds the electronic circuit elements and wire traces.
Boot-up	A series of operations that the Printer runs through when power is first applied including a series of initializing, status testing and a diagnostics program to ensure a ready state.
Buffer	A block of memory, in the Printer or PC, that holds print files until the processor is ready to print them.
Cable	A set of conductors wrapped together and often concealed within insulation, used for signal transfer from one device to another, with connectors on either end that allows the cable to be removed.

Continued on the next page

Glossary of Terms (continued)

Term	Definition
Cache	A type of memory buffer to store data temporarily, used to hold information that is most often exchanged between controller and peripheral, to expedite data transfer.
Calibrating	A procedure to adjust an electro-mechanical device so that it operates within established parameters.
Cleaning Roller	High tack Rollers positioned just after the input Hopper to lift debris off the card as it rolls over it. A clean card surface improves print quality.
CD (Compact Disc)	A 4.75 inch (12 cm) optical disk that stores data, written too and read from using a laser.
DMA (Direct Memory Access)	Channels designated within the Windows operating environment that are used for dedicated high-speed communication between the PC and the Printer port.
Centronics	A parallel communications interface that has become the standard for connections to Printers, designed by the Centronics Corp.
Coercivity	The property of a Magnetic Stripe that indicates the amount of force needed before magnetic saturation, measured in Oersted (Oe).
Color matching	The process of adjusting color hue, saturation and brightness, to duplicate a desired color. An algorithm within the Driver, which adjusts the color balance and provides output with the desired color, automates this process.
Compressed air	Air stored in a tank or produced by an aerosol can, delivered by through nozzle at a high speed. Used in the Printer to blow out debris.
Contrast	The degree of difference in luminance of two areas.
Control panel	The panel on the Printer from which the user can control Printer functions. The Printer is usually composed of the control buttons and an LED or LCD display.

Continued on the next page

Glossary of Terms (continued)

Term	Definition
CR-79	A card dimension standard of 2.0625" L X 3.3125" W (+/-0.002" W, +/-0.005" L) or 52.400 X 84.150 mm.
CR-80	A card dimension standard of 2.125" X 3.370" (+/-0.002" W, +/-0.005" L) or 53.975 X 85.598 mm.
CR-90	A card dimension standard of 2.375" X 3.625" (+/-0.002" W, +/-0.005" L) or 60.325 X 92.075 mm.
CR-100	A card dimension standard of 2.625" X 3.875" (+/-0.002" W, +/-0.005" L) or 66.675 X 98.425 mm.
Cursor	The marker in the LCD Display Window that indicates the active selection.
Darkness	A reference to color saturation.
DB-9	A 9 pin, D-shaped connector, typically used in serial port interfaces.
DC Motor	A Motor that works on DC with continuous motion.
DC (Direct Current)	Electronic flow that is unidirectional, flowing from the positive (+) to negative (-) of a power source.
Default	A setting or parameter that comes preset from the factory in Driver or firmware. Performance parameters may be customized in the Driver, but can be reset to the factory values usually through the push of the default button. The default values for the firmware are usually denoted on a label attached to the Printer.
Defrag	Abbreviation for defragmenting. The process of reformatting data on a hard Drive so that it uses space more efficiently.
DIP switches (Dual In-line Package Switches)	A small array of mechanical switches installed on the board that can be configured to change Printer operations including providing a variety of self-tests.

Continued on the next page

Glossary of Terms (continued)

Term	Definition
Direct-to-Card (DTC) Printing	The Direct-to-Card printing process prints digital images directly onto any plastic card with a smooth, clean, glossy PVC surface.
Dither	A system of distributing dots to control the hue, brightness and/or saturation. In monochrome printing, this controls the brightness. In color printing, dithering can supply a larger color gamut than non-dithering. In the Driver, dither modes can be selected to provide better image quality depending on the type of image to be printed.
Dongle	A peripheral that attaches to a port to act as a key for an installed application. The PC is able to run that application only when the dongle is installed. Typically, it works as a pass-through device and is connected in serial to the parallel cable.
Dot	The smallest unit of an image that the Printer is able to produce. The smaller the dot, see dot pitch, the sharper the image.
Dot pitch	A measurement of image sharpness denoting the width of the dots that make up a pixel. The smaller the pitch, the sharper the image.
Download	The transfer of a data file from one device to the other over a network or cable, typically from the Internet to a PC.
DPI (Dot Per Inch)	A measurement of the Printer resolution indicating how many dots a Printer can produce in a linear inch.
DRAM (Dynamic Random Access Memory)	A microchip based volatile memory storage device. The Printer uses this to buffer a print job, transferred from the PC, until the Printer controller is able to process the packet.
Driver	Software utility installed in Windows, that interfaces an application to rasterize image data and include command codes so the Printer can process the file.
Duplex Printing	Printing on the front and the back of the card.

Continued on the next page

Glossary of Terms (continued)

Term	Definition
Dwell Time	The speed at which the card moves across the lam Roller, measured in seconds/inch (secs/in). This may be adjusted in the Driver to ensure adhesion and card flatness.
Dye Migration	The diffusion of dye out of the card surface and into another receptive surface, such as a vinyl pouch card holder, resulting in a faded image.
Dye-Sublimation	Also called dye diffusion/thermal transfer, it is the process of heating a dye suspended in a cellulous substrate until the dye can flow, diffusing into the dye receptive surface of the card or InTM. This produces the image in the surface of the card.
E-card	An abbreviation for electronic card. A generic term used to reference any card with built-in electronic devices such as smart cards or prox cards.
E-card Docking Station	The device in the Printer that accepts smart cards with an ISO smart card contact station. This allows the user to write to the smart card chip with a standard RS-232 interface in the back of the Printer or with the optional built-in encoder.
Edge-to-Edge	Refers to the maximum printable area on a card resulting in printed cards with virtually no border.
ECP Mode (Enhanced Capabilities Port Mode)	A type of parallel port mode, developed by Microsoft, to increase the port throughput and improve performance.
EE Memory	An abbreviation for EEPROM.
EEPROM (Electrically Erasable Programmable Read Only Memory)	A microchip based non-volatile memory storage device that can be rewritten in the field. The chip can hold new values as the Printer adapts its operational parameters.
Encoder (smart card)	An electro-mechanical interface to transfer data from the PC to a chip or Magnetic Stripe built into the card.

Continued on the next page

Glossary of Terms (continued)

Term	Definition
Encoder (wheel)	An electromechanical device, attached to a shaft that detects the change in rotational position, incremented to count ticks per revolution. The Printer's encoder wheel both detects motion and measures the amount of rotation in the movement of the Ribbon.
Engine	A generic term for a collection of systems and mechanisms that is dedicated to executing a specific function. A Printer that also laminates would have both a print engine and a lamination engine.
EOF (End Of Form)	The trailing edge of the card, detected to indicate when the Printer should stop printing.
EPP (Enhanced Parallel Port)	A type of parallel port mode, developed by Intel, to increase the port throughput.
EPROM (Electrically Programmable Read Only Memory)	A microchip based non-volatile memory storage device that cannot be rewritten in the field. Firmware for many Fargo Printers is stored on these chips and so a change of the chip is necessary for an upgrade.
Escape sequence	A string or control character that indicates to the processor that what follows is a command and not data.
ESD (ElectroStatic Discharge)	The discharge of static electricity (high voltage, low current) that can damage electronic devices.
Ethernet	A system of networking a series of computers for the sharing of data or peripherals.
Film	A thin flexible transparent sheet used to carry dye-impregnated material or resin to be transferred to the card.
Firmware	The instruction set, stored in chip memory, inside the Printer that controls functional and operational data. Some models require a chip change for updates; some firmware can be changed by reprogramming from the PC.

Continued on the next page

Glossary of Terms (continued)

Term	Definition
Flash Memory	A microchip based non-volatile memory device that holds its data when power is removed. This allows for field reprogramming of the Printer commands, such as Printer firmware upgrades, without the necessity of changing chips.
Font	A character set similar in style and form. Fonts can be graphical or mathematical constructs, represented by a series of dots or an assembly of curves and lines.
FPGA (Field Programmable Gate Array)	A microchip with configurable logic circuits installed that is programmed to act as the Printer's central processor.
Full bleed	Printing that covers the entire card surface.
Gamma	The degree of contrast of an image or the display of a monitor determined by the slope of a characteristic curve relating optical density to relative log exposure.
Glossy / Matte	A smooth polished surface in comparison to a rougher matte surface. Fargo matte cards have a surface index (Ra) of approximately 65 microinches while glossy have a Ra = 3.
Glossy PVC	A card made of PVC with a smooth polished surface (Surface roughness of approximately 0 - 10 micro-inches). This is required for direct to card dye-sublimation printing.
Graphical Device Interface (GDI)	A Windows standard for protocol between Drivers and applications and the Windows interface. An application uses a Driver to rasterize the data in the format necessary for the Printer but also for the Windows interface to execute the print commands.
Gray Scale	A graduation through the various brightness levels from white to black.
Halftoning	A process in monochrome printing that simulates continuous tone by using changes to the distribution of single dots. Increasing the number of dots in a given area increases the darkness even though the individual dots stay the same size.

Continued on the next page

Glossary of Terms (continued)

Term	Definition
Hard Drive	A high capacity storage device in a PC consisting of non-removable magnetically encodable platters.
Hardware	Physical components of a system such as the Printer, the PC, the power supply.
HDP (High Definition Printing™)	The High-Definition Printing process prints full-color images onto clear HDP transfer film (InTM). The HDP film is then fused to the card through heat and pressure via a heated Roller. The Printhead is capable of 256 shades with a sharper print and better color match.
Head	Abbreviation for Printhead.
Heat sink	A device used to dissipate heat into the ambient.
Heat Seal	A resinous film transferred by the Printhead onto the back of an HDP intermediate transfer film to facilitate adhesion.
HiCo (High Coercivity)	The coercivity value of magnetic media between 2500 - 4000 Oe (ISO 7811-6). Fargo's High Coercivity encodes at 2750 Oe.
HTML (HyperText Markup Language)	A standard protocol used to format text files for use in a browser or on the Internet.
HTTP (HyperText Transfer Protocol)	A standard protocol by which computers can transfer data, compatible through multiple platforms.
IC (Integrated Circuit)	An electronic device that contains many individual circuits interconnected and placed within a discrete package.
ID (Identification)	An abbreviation for identification.

Continued on the next page

Glossary of Terms (continued)

Term	Definition
IEEE 1284 (Institute of Electrical and Electronics Engineers 1284)	A standard method of signaling for a bi-directional parallel interface on personal computers. To ensure proper Printer communications and image output, Fargo recommends a parallel interface cable that complies with this specification.
Image	A collection of pictures or graphical elements that compose the visual features on a card. Also refers to the digital representation.
Input	Any data or material being transferred to the Printer.
Input Hopper	The area of the Printer that stores the blank cards, ready to print.
Intermediate Transfer Media (InTM)	A thin flexible material coated with a resin material into which the dye is transferred from the Ribbon by the Printhead. The film is then transferred to the card surface by the hot lamination Roller.
ISO	For the Greek, "iso", meaning same. Used to represent data from the International Organization for Standardization.
JIS II (Japanese Industrial Standard)	The standard for encoding to a Magnetic Stripe provided by the Japan Standards Association. The single track is as wide as ISO tracks 1 and 2 combined and in the same approximate location as those tracks but on the front of the card. The coercivity level is 600 Oe.
K Panel	An area of a multicolored Ribbon (e.g., YMCK) that contains black resin for transfer to the card surface. Also used in reference to the application of preference to items printed on the card - those using the black panel in lieu of a process (YMC) black.
Lamination	The application of a film or resinous substance, fused by heat and pressure, to the surface of a card.
LAN (Local Area Network)	An array of several computers connected through a series of data transfer cables for the sharing of data and peripherals.

Continued on the next page

Glossary of Terms (continued)

Term	Definition
Landscape	A document layout that is viewed with the document's long axis in a horizontal orientation.
LCD (Liquid Crystal Display)	A device that contains a liquid crystal between two pieces of polarized film through which reflected or ambient light can pass. When a current is applied, the liquid's polarity changes and blocks the passage of the light resulting in an opaque area of the display. The areas are arrayed to form characters.
LED (Light Emitting Diode)	A semiconductor that emits light when a current is applied.
Media	A generic reference to anything onto which the Printer can transfer an image including cards, Ribbon and film.
LoCo (Low Coercivity)	The coercivity value of magnetic media between 250 - 600 Oe (ISO 7811-2). Fargo's Low Coercivity encodes at 300 Oe.
LPT Port (Line Printer Port)	The system abbreviation for a PC's parallel Printer port.
Magnetic encoding	The process of orienting successive magnetic bits to produce a serial data string.
Magnetic stripe	An area of the card with an applied or impregnated ferrous material that may hold encoded data through a series of prescribed polarity changes.
Magnetic Track	An area of a magnetic strip running the length of the card, with a given width and position, constitutes a track. This is the area dedicated to one data string, restricted to specific rules of format. ISO Standards specify three magnetic tracks on the back of a card. The JIS standard specifies one track on the front.
Magnetic Verify	A process to confirm proper magnetic encoding. After encoding, the information is read off back and compared to the intended string.

Continued on the next page

Glossary of Terms (continued)

Term	Definition
MB (Megabyte)	A unit of storage that equals 1,048,576 bytes.
Memory	A generic term for any device that stores digital information using magnetic media or digital chip storage device.
Menu	A descriptive list of headings above nested functions that aid navigation to a specific operation. These are found in computer applications, with the heading at the top of a subset of like functions. They are also on the Printer LCD control panel.
Monochrome	An image composed of a single color.
Network	A series of computers connected by data transfer cable for communication and sharing of functions and peripherals.
Oersted (Oe)	The unit of magnetic field strength named after Dutch scientist Hans Christian Oersted who found the science of electromagnetism.
Offset	The prescribed distance between a reference point and the target point. The offset in card printing may refer to the position of the image relative to the leading edge or the distance of the start of magnetic encoding from the leading edge of the card.
O-Ring	A rubber ring used as a belt in several media driving applications.
OS (Operating System)	The instructions installed on the computer hard Drive that run the computer's operations and applications. The Driver used for any given OS will differ from other platforms. The correct version Driver must be loaded for the Printer to interface with the OS and the application to print.
Output	Any product of the Printer including card image, encoded data and lamination.
Output Hopper	The portion of the Printer that accepts the completed cards.
Overlay	A resin-like substance that is transferred by the Printhead to the card surface over a printed dye image to prevent image fading, increase abrasion durability and prevent dye migration.

Continued on the next page

Glossary of Terms (continued)

Term	Definition
Oversized Cards	Oversized cards are used for more efficient visual identification and are available in many non-standard sizes. The most popular sizes are CR-90 (3.63" x 2.37"/92mm x 60mm) and CR-100 (3.88" x 2.63"/98.5mm x 67mm).
Overlamine	Protective clear or holographic material to increase security and durability applied over the printed surface with a hot Roller.
(Thin Film) Overlamine	A 0.25-mil thick resin material that enhances card security and durability applied over the printed surface with a hot Roller. Available as clear or with embedded holographic-type security images.
Parallel	A method of data transfer in which serial data is divided into sections and sent simultaneously down parallel wires to speed transfer rate.
Parallel port	A communication socket on a device that allows for parallel data transfer.
PC (Personal Computer)	A stand-alone, programmable, electronic device that can store, retrieve and process data consisting of a CPU, mouse, keyboard and monitor.
PCB (Printed Circuit Board)	A solid, multi-layered plate on which electronic elements are attached, either through the board or on the surface.
Peel	The removal of a film or Ribbon from a card surface (at a perpendicular angle) to ensure proper transfer, then separation, from the card surface.
Peel-Off	A bar on the lamination section that holds the film at the correct position and provides proper peel angle.
Peripheral	Any device that is attached externally to a PC. These often share the same data cable or port as a Printer and may be the source of communication problems.

Continued on the next page

Glossary of Terms (continued)

Term	Definition
Pinch Roller	A free spinning (non-Driven) Roller that presses the card against the Drive Roller, on the opposite side, to ensure an adequate normal force for proper traction.
Pixel	Short for picture element. The smallest element of a graphic.
Platen	The hard rubber Roller that Drives the media through the Printer, providing support to the backside of the media during printing or laminating.
PET	Abbreviation for polyester terephthalate, often called polyester. Sheets of PET are laminated with sheets of PVC to produce thermal acceptance composite cards.
Port	A communication interface, serial or parallel, used for the transference of data.
PolyGuard Overlamine	A 1-mil or .6-mil thick polyester material that enhances card security and durability applied over the printed surface with a hot Roller. Available as clear or with embedded holographic-type security images.
Portrait	A document layout that is viewed with the document's long axis in a vertical orientation.
Potentiometer	An electronic resistor with a variable resistance value that can be mechanically set.
Print Driver	A software utility that serves as an interface between the Printer and the Windows GDI (Graphical Device Interface), making the Printer's functions available through the software application. It also provides the format information for the rasterizing of the print file including any necessary escape or function commands.
Print Job	A file of one or more cards for the Printer to print, including image data and Printer functions, transmitted through the parallel interface and at times stored temporarily in the print buffer and spooler.
Print Server	A device used to connect and control a Printer on a network.

Continued on the next page

Glossary of Terms (continued)

Term	Definition
Printhead	The device on a Printer that produces the image on the media.
PVC	Abbreviation for polyvinyl chloride, often called vinyl. PVC is the component of the 0.002" thick clear, dye receptive film on the surface of the identification card and is the primary component of the identification card cores.
Queue	A sequence of files or sets of data, awaiting transmission or processing.
Proximity ("Prox") Card	Proximity cards allow access and tracking utilizing contactless technology, usually by communicating through a built-in antenna.
Prox Card Encoder	The Fargo prox card encoder uses an HID ProxPoint® Plus reader mounted on the e-card docking station inside the Printer/encoder. The ProxPoint is a "read only" device producing a Wiegand signal that is converted to RS-232 using a Cypress Computer Systems CVT-2232. Application programs can read information from HID prox cards via a RS-232 signal through a dedicated DB-9 port on the outside of the Printer labeled "Prox."
RAM (Random Access Memory)	A storage device for digital information to be held temporarily, to facilitate processing.
Rasterize	The process of converting the elements of a graphic into a bitmap to be printed.
Reboot	Cycling the power to the Printer so that it resets and reinitializes.
Registration	The quality of the alignment of the separate primary-color images: YMCK.
Resident Font	A set of characters loaded into the Printer memory that can be programmed to print those characters on the card without rasterizing the image.
Resin	A semisolid material.

Continued on the next page

Glossary of Terms (continued)

Term	Definition
Resolution	The number of individual pixel elements in a graphic, taken over a given length, used to indicate the sharpness of the picture and the level of detail. The number of elements in the Printhead determines Fargo Printer resolution.
RFI (Radio Frequency Interference)	Electromagnetic waves radiated by poorly shielded cables or electronic devices that interferes with the operation or data transfer of another device.
RGB (Red/Green/Blue)	The three primary colors of the luminance, or additive, model. Combinations of these three colors can produce practically all the colors of the spectrum that humans can detect. Computer monitors operate on an RGB model.
Ribbon	The dye impregnated film that is used for color printing.
Ribbon cable	Parallel wires held flat in a row by plastic insulation.
RibbonTraq	A Fargo Electronics method of placing bar code-like marks on the transition area between color panels. These marks are arranged for detection by a reflective Sensor array for the identification of Ribbon type and the Ribbon position.
RMA number (Return Merchandise Authorization number)	A number, acquired from Fargo Support, that authorizes the return of merchandise for repair or credit.
Roller	Elements of the Printer used for the transport of media consisting of a rotating steel shaft (for Ribbon) or a rotating steel shaft with a rubber cylinder installed at the shaft midpoint (for moving cards).
RS-232	An interface standard, established in 1969 by the Electronic Industries Association, regarding the connecting of computer peripherals.
Saturation	A measure of the degree of color, from gray, with the same brightness.

Continued on the next page

Glossary of Terms (continued)

Term	Definition
Self-test	A pre-determined print file used to confirm Printer operation typically sent from the Driver or stored in the Printer's memory.
Sensor	An electro-mechanical/electro-optical device used to indicate a change in state in the Printer such as when a card reaches a certain location.
Serial communications	The transfer of data, one bit at a time and in sequential order, using a single wire.
Serial interface	A sub D 9 pin input/output port on the Printer, used for serial communication with the PC for AS400 operating systems or for e card encoding.
SIMM (Single In-Line Memory Module)	An array of memory chips, attached to a printed circuit board that installs in a slot on the main board.
Simplex	Single-sided printing.
SmartGuard	An application from Fargo Electronics that allows users to prevent access to the Printer through the use of a personally encoded smart card.
SmartGuard™	SmartGuard is a Printer security option that uses a custom access card and a built-in reader to restrict Printer access. Only a valid access card can enable the Printer to print cards.
SmartShield™	This option allows the Printer to print custom, security images on the card that reflect under a black or UV light source.
Smart Card	Smart cards have an embedded computer circuit that contains either a memory chip or a microprocessor chip. There are several types of smart cards: Memory, Contact, Contactless, Hybrid (Twin), Combi (Dual Interface), Proximity and Vicinity.
Software	Instructions saved in computer memory that directs the computer to perform certain tasks and functions.
Spooler	A computer application that allows the spooling of print jobs.

Continued on the next page

Glossary of Terms (continued)

Term	Definition
Spooling	Rather than moving a print job directly to the Printer, the job is written to the disk so that the user can access the application faster while Windows takes care of printing in the background.
SS (Start Sentinel)	The character denoting the end of a magnetic data string.
Stacker	The device that moves the finished cards onto the output column, ordering them "First In, First Out".
Stepper Motor	A Motor whose shaft turns in discrete steps, rather than continuously.
String	A sequence of characters that form a line of data.
Surface mount	A method of mounting circuit elements onto the surface of a circuit board, attached at solder pads, rather than through holes in the board.
Surge Protector	An electronic device, placed in serial to the Printer's power supply, that prevents damage to the Printer from electronic surges and electrical current that is outside of the normal parameters.
Switch box	An electromechanical device to which a user may connect several peripheral devices to the parallel port simultaneously, yet using the selector switch to designate the active port.
TAC	Thermal Acceptance Composite cards. Card stock produced by laminating sheets of PVC with sheets of PET for better thermal distortion resistance. Ultra III cards.
Temp file	A temporary file, generated automatically by Windows, to store the information for an active document. Windows should delete these files when the application is closed.
Test-print	A file stored in or generated through windows that is sent to the Printer to test basic functionality.
Thermistor	An electronic resistor on the Printhead with a resistance value that varies in proportion to the heat to which it is exposed.

Continued on the next page

Glossary of Terms (continued)

Term	Definition
Thermocouple	A device for measuring temperature using a junction of two wires of dissimilar metals that produce a voltage when heated that varies proportionally with the temperature.
Through-hole	A method of mounting circuit elements with the leads passing through holes in the circuit board and soldered on the opposite side.
Timeout	An interruption of a print job that occurs when a function is not completed in the time allotted by the operating system.
TOF (Top of Form)	The leading edge of the card, as it travels through the Printer.
Track	The area on a Magnetic stripe designated to contain the magnetic data string.
Troubleshooting	The process of investigating and determining the cause of a problem.
TrueType (TT)	A font format that produces each character using a mathematical equation, rather than a graphical representation, resulting in a much sharper, cleaner image.
UltraCard	The Fargo brand of card stock, recommended for use in Fargo Printers, with the necessary glossy surface and composed of PVC.
UltraCard III	The Fargo brand of card stock, recommended for use in Fargo Printers that laminate, with the necessary glossy surface and composed of PVC and PET to prevent heat distortion.
Update	The process of installing a new revision of software or firmware to implement new changes to the Printer's command codes and procedures.
UPS (Un-interruptible Power Supply)	An AC power supply, typically powered by batteries, which provides temporary power to the PC or Printer during an interruption of the supply voltage.

Continued on the next page

Glossary of Terms (continued)

Term	Definition
USB (Universal Serial Bus)	A 1.5M/sec (12Mbit/sec) serial communication interface that can support 127 separate devices consisting of 4 wires: power, ground, data in and data out.
Virtual Memory	A technique used by Windows when chip memory is exhausted, in which data is written to the hard to hold data temporarily and support Window's operations.
Wrinkle	The appearance in the card image of wavy or arched lines, either colored or clear, caused by improper film or Ribbon tension.
YMC	The designation of colored Ribbon by the panels of color in the order in which they are printed: Yellow (Y), Magenta (M), Cyan (C).
YMCK	The designation of colored Ribbon by the panels of color in the order in which they are printed: Yellow (Y), Magenta (M), Cyan (C), Black (K).
YMCKH	The designation of colored Ribbon by the panels of color in the order in which they are printed: Yellow (Y), Magenta (M), Cyan (C), Black (K), Heat Seal (H).
YMCKK	The designation of colored Ribbon by the panels of color in the order in which they are printed: Yellow (Y), Magenta (M), Cyan (C), Black (K), Black (K) (the second K is for backside, black only printing).
YMCKO	The designation of colored Ribbon by the panels of color in the order in which they are printed: Yellow (Y), Magenta (M), Cyan (C), Black (K), Overlay (O).
YMCKOK	The designation of colored Ribbon by the panels of color in the order in which they are printed: Yellow (Y), Magenta (M), Cyan (C), Black (K), Overlay (O), Black (K) (used for backside, black only printing).

Section 14: Index

A

About button, 5-14
 AC - Alternating Current, 13-1
 Accepted Card Thickness, 2-2
 Accepted Card Types, 2-2
 Accepted Standard Card Sizes, 2-2
 Access Card, 13-1
 Adhesion, 13-1
 Adjusting the Image Darkness, 4-44, 4-46
 Agency Listings, 2-2
Algebraic, 5-20, 13-1
 ANSI (American National Standards Institute), 13-1
 AS400, 13-1
 ASCII (American Standard Code for Information Interchange), 13-1
 ASCII Code, 5-56
 ASCII Offset, 5-51
 AT, 13-1
 automated Flipping Module, 2-14

B

B (Black), 13-1
 Barcodes, 13-2
 Batch print, 13-2
 Battery Back-up, 13-2
 Bi-directional, 13-2
 BIOS (Basic Input/Output System), 13-2
 Bit, 13-2
 Bit Density, 5-48
 Bit map, 13-2
 blocked Sensor, 4-33
 Board, 13-2
 Boot-up, 13-2
 Buffer, 13-2

C

Cable, 13-2
 Cache, 13-3
 Calibrate tab, 4-36, **4-50**, 5-39
 Calibrating, 13-3
Cancel button, 2-8
 Card Cleaning Roller, 2-8
 Card Design, 2-13
Card Feeding Errors, **4-10**, **4-12**, **4-15**, 4-16, 4-18, 4-20, 4-22, 4-25, 4-27, 4-29, 4-31, 4-33
 card grid, 5-64
 card grid area, 5-63
 card grid lines, 5-65
 card input, 5-95
 Card Input Hopper, 2-8
 Card Input Hopper Capacity, 2-2
 card orientation, 5-66
 card output, 5-95
 Card Size, 2-13

card stock scratches, 4-41
 Card Surface, 2-13
 cards look pixilated or grainy, 4-53
 CD (Compact Disc), 13-3
 Centronics, 13-3
 Character, 5-56
 Character ASCII Offset, 5-51
 Character Parity, 5-52
 Character Size radio buttons, 5-49
 Cleaning Card Feed/Cleaning Rollers, 6-4
 Cleaning Cards, 6-2
 Cleaning Inside Printer, 4-42
 Cleaning Pad, 6-5
 Cleaning Pads, 6-2
 Cleaning Printer's Interior, 6-5
 Cleaning Roller, 13-3
 Cleaning the Printhead, 4-41
 Clear Protective Overlay Panel, 2-9
 Coercivity, 13-3
 Color matching, 13-3
Color Matching, 5-20
 Color Matching software, 5-20
 Colored Resin, 2-10
 Colors, 2-2
 Communication Errors, 4-4, 4-5
 Compressed air, 13-3
 Contrast, 13-3
 Contrast / Gamma, printed image, 5-35
 Control panel, 13-3
 CR-100, 13-4
 CR-79, 13-4
 CR-80, 13-4
 CR-80 card size, front/back, 5-79, 5-80, 5-81
 CR-90, 13-4
 CSA, 2-1
 Cursor, 13-4
 customized ID software applications, 5-55

D

Darkness, 13-4
 Data Cables, 4-36
 DB-9, 13-4
 DC (Direct Current), 13-4
 DC Motor, 13-4
 Default, 13-4
Default button, 5-38, 5-45
 default ISO Standard selections, 5-48, 5-52
 default location, 5-83
 defined area, 5-66
 Defined Area arrows, 5-67
 Defined area(s), 5-82
 Defined Area(s) check box, 5-82, 5-83, 5-84, 5-88, 5-89, 5-91, 5-92, 5-97, 5-99, 5-100, 5-103
Defined Area(s) option, 5-59, 5-64, 5-80
 Defined/undefined area(s), 5-79, 5-81
 Defrag, 13-4
Delete button, 5-67

Device Option tab, 4-29
 Diagnostic Utility / Diagnostics Tool, 5-10
 dimension boxes, 5-83
 Dimensions, 2-2
 DIP switches (Dual In-line Package Switches), 13-4
 Direct-to-Card (DTC) Printing, 13-5
Disable Printing option, 5-27, 5-32
 Disables Magnetic Verification, 4-54
 disk cleanup utility, 4-5
 Dither, 13-5
 DMA (Direct Memory Access), 13-3
 Dongle, 13-5
 Dot, 13-5
 Dot pitch, 13-5
 Download, 13-5
 DPI (Dot Per Inch), 13-5
 DRAM (Dynamic Random Access Memory), 13-5
 Driver, 13-5
 DTC400/DTC300/DTC300M Card Printer, 7-1
 Duplex Printing, 13-5
 Dwell Time, 13-6
 Dye Migration, 13-6
 Dye-Sub Intensity setting, 4-45
 Dye-Sublimation, 2-7, 13-6
 Dye-Sublimation Cyan Panel, 2-9
 Dye-Sublimation Magenta Panel, 2-9
 Dye-Sublimation Yellow Panel, 2-9
 Dye-Sublimation-Only Print Ribbons, 2-11

E

E-card, 13-6
 E-card Docking Station, 13-6
 ECP Mode (Enhanced Capabilities Port Mode), 13-6
 Edge-to-Edge, 13-6
 EE Memory, 13-6
 EEPROM (Electrically Erasable Programmable Read Only Memory), 13-6
 embedded contaminants, 2-13, 4-42
 Emissions Standards, 2-2
 Enable MLE Support checkbox, 5-50
 Encoder (smart card), 13-6
 Encoder (wheel), 13-7
 End Sentinel (ES), 5-55
 Engine, 13-7
 EOF (End Of Form), 13-7
 EPP (Enhanced Parallel Port), 13-7
 EPROM (Electrically Programmable Read Only Memory), 13-7
 EPROM version number, 4-54, 4-55
 Escape sequence, 13-7
 ESD, 1-2, 5-4, 6-1, 8-1
 ESD (ElectroStatic Discharge), 13-7
 Ethernet, 13-7
 excessive resin printing problems, 4-48
 exposed to static electrical discharges, 6-2

F

Fargo Technical Support, 11-1
 Fargo Technical Support via the Web, 11-1
 FCC, 2-1

feed card into encoder, 4-5
 Field Separator (FS), 5-55
 Film, 13-7
 Firmware, 13-7
 Flash Memory, 13-8
 Flipper Table Module, 2-14
 Font, 13-8
 For Overlay Only, 5-61
For Print and Overlay, 5-61
 FPGA (Field Programmable Gate Array), 13-8
Front and Back radio buttons, 2-14
 Front Cover, 2-8
 Full bleed, 13-8
Full Card option, 5-59, 5-79

G

Gamma, 13-8
 Glossy / Matte, 13-8
 Glossy PVC, 13-8
 Graphical Device Interface (GDI), 13-8
 Gray Scale, 13-8

H

Halftoning, 13-8
 Hard Drive, 13-9
 hard Drive space
 adequate or inadequate, 4-5
 HDP (High Definition Printing™), 13-9
 Head, 13-9
 Headlift Motors, 4-33
 Headlift Sensors, 4-33
 Heat Seal, 13-9
 Heat sink, 13-9
 HiCo (High Coercivity), 13-9
 high-resolution, 24-bit color images, 4-53
Horizontal adjustment, 5-41
 HTML (HyperText Markup Language), 13-9
 HTTP (HyperText Transfer Protocol), 13-9
 Humidity, 2-3

I

IC (Integrated Circuit), 13-9
 ID (Identification), 13-9
 ID format, 5-22
 Identification Card sample, 5-83
 IEEE 1284 (Institute of Electrical and Electronics Engineers 1284), 13-10
 Image, 13-10
 Image Color tab, 5-20, 5-35
 Image Darkness option, 5-94
 Image Placement, 4-51, 4-52
 Image Placement option, 5-95
 image placement problems, 4-51
 Image Placement value, 5-95
 Image Position controls, 5-40
inches or **mm** option, 5-7
 incorrect image darkness problems, 4-44
 increase Printhead heat, 5-94
 Input, 13-10

Input Hopper, 13-10
 integral resistor, 6-2
 Interface, 2-3
 Intermediate Transfer Media (InTM), 13-10
 internal electrical components, 6-2
 internal Printer settings, 5-39
 ISO, 13-10
 ISO 7811-2 Magnetic Stripe, 5-54
 ISO encoded data format, 5-47
 ISO Standard selections, 5-52
 ISO Standard settings, 5-45
 ISO Track Locations, 5-54

J

JIS II (Japanese Industrial Standard), 13-10

K

K Panel, 13-10
K Panel Resin options, 5-67, 5-88
 K Panel Resin tab, 5-78

L

Lamination, 13-10
 Lamination Drive, 8-2
 Lamination Drive Stepper, 8-2
 Lamination Roller Lift, 8-2
 Lamination Sensor Calibration, 4-54
 LAN (Local Area Network), 13-10
 Landscape, 13-11
Landscape orientation, 5-40
 LCD (Liquid Crystal Display), 13-11
 LED (Light Emitting Diode), 13-11
 less heat / more heat, 5-33, 5-34, 5-36, 5-37
 LoCo (Low Coercivity), 13-11
 LPT Port (Line Printer Port), 13-11
 LRC Generation, 5-52
 LRC Generation Mode, 5-52

M

magnetic data, 5-101
 Magnetic Encoder, 4-18
 Magnetic encoding, 13-11
 Magnetic Offset option, 5-101
 Magnetic Offset value, 5-101
 Magnetic stripe, 13-11
 , 4-15
 Magnetic Stripe Encoding Module, 5-44
 Magnetic Stripe reader, 4-15
 Magnetic Track, 13-11
 Magnetic Track Options, 5-45
 Magnetic Track Selection, 5-45, 5-46
Magnetic Track Selection option, 5-45
 Magnetic Verify, 13-11
 maximum adjustment range, 5-96, 5-101
 MB (Megabyte), 13-12
 Media, 13-11
 Memory, 2-3, 13-12

Menu, 13-12
 Metallic Resin, 2-10
Monitor, 5-20
 Monochrome, 13-12
 Monochrome Dye-Sub (B), 4-54
 Monochrome Resin (K), 4-54
 Motor Voltages (when active), 8-2
 Multi-Language Extension (MLE), 5-50

N

Network, 13-12
None, 5-20

O

Oersted (Oe), 13-12
 Offset, 13-12
Omit Signature Area setting, 5-64
On LED, 4-54, 4-55
 onscreen card design, 5-84
 Operating Temperature, 2-3
 optional Magnetic Stripe Encoding Module, 5-44
 O-Ring, 13-12
 OS (Operating System), 13-12
 Output, 13-12
 Output Hopper, 13-12
 Overlamine, 13-13
 Overlay, 13-12
 Overlay / Print Area, 5-64, 5-65
 Overlay / Print Area options, 5-61
 Overlay / Print Area tab, 5-58
 Oversized Cards, 13-13

P

Parallel, 13-13
 Parallel port, 13-13
Pause button and LED, 2-8
Pause/Resume button, 4-54, 4-55
 PC (Personal Computer), 13-13
 PCB (Printed Circuit Board), 13-13
 Peel, 13-13
 Peel-Off, 13-13
 Peripheral, 13-13
 PET, 13-14
Photo, 5-21, 5-30
 Pinch Roller, 13-14
 Pixel, 13-14
 , 4-41
 Platen, 13-14
 PolyGuard Overlamine, 13-14
 poor image quality problems, 4-51, 4-52
 Port, 13-14
 Portrait, 13-14
Portrait or **Landscape**, 5-8
 Portrait, Landscape, or Rotate 180 Degrees, 5-40
 positive / negative Print Length value, 5-96
 POSITIVE / NEGATIVE value., 5-95
 Potentiometer, 13-14
 Power Port, 2-8
 power/data cables, 4-36

Premium Resin Black (K), 2-10
 prevents magnetic encoding, 5-50
 Print All Black With K Panel, 5-78
 print and overlay, 5-58
 Print Back Side First option, 5-24
 Print back side only, 5-25
 print both sides, 5-22, 5-23
Print Both Sides option, 2-14, 5-23, 5-25
 Print Drive Stepper, 8-2
 Print Driver, 13-14
 Print Job, 13-14
Print K Only options, 5-89, 5-91, 5-92, 5-97, 5-99, 5-100, 5-103
 Print Length option, 5-96
 Print Method, 2-3
 Print Ribbons, 2-9
 Print Server, 13-14
 print the first page of a two-page document, 5-24
Print YMC Under K option, 5-89
 printable area, 5-39
 Printed cards
 dark or light, 4-43
 printed image diagram, 5-41
 Printer Cleaning Kit, 6-4
 Printer Driver setup screen, 5-46
 Printer Drivers, 2-3
 Printer's Front Cover, 6-4, 6-5
 Printer's memory, 5-39
 Printhead, 2-8, 13-15
 Printhead Cleaning Swabs, 6-2
 Printhead power cable, 4-36
 printing supplies, 6-5
 Prox Card Encoder, 13-15
 Proximity cards, 2-13
 PVC, 13-15
 PVC laminate, 2-13

Q

Queue, 13-15

R

RAM (Random Access Memory), 13-15
 Rasterize, 13-15
 Reboot, 13-15
 Registration, 13-15
 Regulatory Compliances, 2-1
 Reject Hopper, 4-15
 Reset Printer, 4-36
 Resident Font, 13-15
 Resin, 13-15
 resin black (K) panel, 5-78, 5-79, 5-89
 Resin Black Panel, 2-9
 resin dither, 5-21, 5-30
Resin Heat slide, 5-33, 5-34, 5-36, 5-37
 Resin Thermal Transfer, 2-7
 Resolution, 2-4, 13-16
 RFI (Radio Frequency Interference), 13-16
 RGB (Red/Green/Blue), 13-16
 Ribbon, 13-16
 Ribbon / Cards, 1-2, 5-4, 6-1, 8-1

Ribbon cable, 13-16
 ribbon Panels, 5-23
 Ribbon Sensor Calibration, 4-54
Ribbon Type option, 5-16, 5-28
 Ribbon wrinkle problems, 4-46
 RibbonTraq, 13-16
 RMA number, 13-16
 Roller, 13-16
 Roller Up/Down Error, 4-33
Rotate Front 180 Degrees option, 5-66, 5-84
Rotate Image 180 Degrees option, 5-26, 5-31
 RS-232, 13-16

S

safety issues, 1-2, 4-3, 5-4, 6-1, 8-1, 10-2
 Safety Standards, 2-2
 Saturation, 13-16
 second K Panel, 5-23
 Selecting Orientation - Landscape under Card tab, 5-69
 Selecting Orientation - Portfolio under Card tab, 5-71
 Selecting the number of copies, 5-9
 Selecting the Visual Security Solutions, 5-72, 5-73, 5-74
 Selecting the Visual Security Solutions dropdown menu, 5-70
 Self-test, 4-54, 4-55, 13-17
 Sending data to Track 1, 5-56
 Sensor, 13-17
Sensors button, 5-42
 Serial interface, 13-17
Settings button, 4-51, 4-52
 Shift Data Left checkbox, 5-53
 Shift Data Left option, 5-53
 SIMM, 13-17
 Simplex, 13-17
 Smart Card, 13-17
 SmartGuard, 13-17
 SmartShield™, 13-17
 Software, 13-17
 special precautions, 1-2, 5-4, 6-1, 8-1
 Split 1 Ribbon Panels, 5-23
 Spooler, 13-17
 Spooling, 13-18
 SS (Start Sentinel), 13-18
 Stacker, 13-18
 Standard Resin Black (K), 2-10
 Standard Self-test (YMC), 4-54
 Start Sentinel (SS), 5-55
 Stepper Motor, 13-18
 String, 13-18
 Supply Frequency, 2-4
 Supply Voltage, 2-4
 Surface mount, 13-18
 Switch box, 13-18
 System Requirements, 2-4

T

TAC, 13-18
 Temp file, 13-18
 Test Core Pins (Lam), 4-54
 Test Core Pins (Print), 4-54

Test Print option, 5-13
 Test-print, 13-18
 Tests Magnetic Encoding, 4-54
 Thermistor, 13-18
 Thermocouple, 13-19
 Through-hole, 13-19
 Timeout, 13-19
 TOF (Top of Form), 13-19
 Track, 13-19
 Track 2, 5-46
 Track Data Note, 5-56
 track number (1, 2, or 3), 5-55
 tracks, 5-46
 tracks 1, 2 and 3, 5-56
 troubleshoot the Printer, 11-1
 Troubleshooting, 13-19
 TrueType (TT), 13-19
 TrueType black text, 5-78
 TÜ V-EMC, 2-1

U

UL, 2-1
 Ultra Violet Fluorescing Panel, 2-9
 UltraCard, 13-19
 UltraCard III, 13-19
 UltraCard Stock, 2-13
 unblocked Sensor, 4-33
 Undefined Area(s) option, 5-59, 5-81
 Update, 13-19
 UPS (Un-interruptible Power Supply), 13-19
 USB (Universal Serial Bus), 13-20
 USB Port, 2-8
 Using Clean Printer Option, 5-11
Using the Image Color tab, 4-49

V

Verify data encoded, 4-15
 Vertical / Horizontal adjustment arrows, 5-40
 Vertical / Horizontal Image Position settings, 4-50
Vertical adjustment, 5-41
 Virtual Memory, 13-20

W

Weight, 2-4
 Windows 2000/XP, 4-29, 4-36, **4-50**, 6-4
 Windows 95/98/ME, 4-29
 Windows 98SE, Me, 4-36, **4-50**, 6-4
WordPad, 4-5
 Wrinkle, 13-20

X

X and Y boxes, 5-65, 5-84

Y

Yellow, Magenta and Cyan, 5-35
 YMC, 13-20
 YMCFKO, 2-12
 YMCK, 13-20
 YMCK/YMCKK Print Ribbons, 5-23
 YMCKH, 13-20
 YMCKK, 13-20
 YMCKO, 13-20
 YMCKOK, 2-12, 13-20